

GXS EDI Services



Customizing and Developing Applications with Expedite CICS

Version 4 Release 5

Seventh Edition (November 2005)

This document (GC34-3304-06) contains revisions for MVS only. VSE users should continue to refer to document GC34-3304-04.

© 1998, 2006 GXS, Inc. All rights reserved

Government Users Restricted Rights - Use, duplication, or disclosure restricted.



Contents

.....

- To the readerix
 - Who should read this book ix
 - How to use this book ix
 - Acronyms and other notation conventions x
 - Related Expedite/CICS books x
 - Other related books..... xi
 - Changes in Expedite/CICS Version 4 Release 5 xi
- Chapter 1. Introducing Information Exchange and Expedite/CICS 1
 - Understanding Information Exchange 2
 - Using Information Exchange communications..... 3
 - Using Expedite/CICS to communicate with Information Exchange 4
 - Program Interface Overview 5
 - Display Application Overview..... 5
 - Command processor overview..... 7
 - Batch Interface Overview 10
 - Activity monitor overview 10
 - Managing data 11
 - Receiving acknowledgments 13
 - Using problem determination tools..... 14
 - Important files in Expedite/CICS 15
 - Providing security 16
 - Extended Security Option 16
 - Charges 16
- Chapter 2. Customizing Expedite/ CICS 17
 - Performing initial administration tasks 18
 - Changing the SYSTEM/DEFAULT password..... 19
 - Customizing user administration options..... 22
 - User administration field descriptions 22
 - Customizing system administration options 30
 - System option details 30
 - Customizing EDI destination addresses..... 34
 - EDI translate table example 38
 - EDI send options..... 40
 - Customizing Expedite/CICS transaction names 43
 - Customizing trace options 48

Trace option field descriptions.....	49
Customizing Information Exchange options.....	53
Customizing Display Application menus	55
Display Application menu processing	56
Reorganizing system files.....	57
Chapter 3. Developing an Expedite/CICS application	59
Planning application development.....	60
Checklist for describing your current process.....	60
Checklist for defining new application requirements.....	62
Checklist for matching Expedite/CICS features with application requirements	63
Understanding the Expedite/CICS command processor.....	66
Invoking the command processor	66
Command processor responses	71
Processing errors.....	72
Expedite/CICS processing error messages.....	72
Information Exchange processing error messages	73
Identifying what user programs must be developed	76
Designing an application	79
Session end considerations.....	86
Maximizing system performance.....	86
Configuration alternatives.....	87
Using the TCP/IP function of Expedite/CICS	88
TCP/IP override parameter field descriptions.....	89
Changing the override parameter values.....	91
Sending data to Information Exchange.....	92
Send processing considerations	92
Defining how send data will be processed.....	98
Asynchronous send processing	98
Synchronous send processing	100
Processing send request errors	102
Send processing options.....	103
Specifying Information Exchange control fields	105
Specifying the common data header	108
Receiving data from Information Exchange	109
Receiving messages and files.....	109
Receiving responses in your mailbox	109
Receiving acknowledgments.....	109
Receive processing considerations and options	110
Receive error processing.....	117
Issuing synchpoints from receive programs.....	123
Chapter 4. Working with additional Expedite/CICS application features.....	125
Working with Information Exchange libraries	126
Understanding acknowledgments.....	127
Information Exchange acknowledgments.....	127
Expedite/CICS completion-notification acknowledgments	132
Application acknowledgments.....	132
Working with Expedite/CICS exit routines	134
Working with information collection exits	134
Working with data management exits.....	138
Information Exchange Common Data Header (CDH).....	143
Using audit trails.....	150
Retrieving audit trails.....	150
Audit record formats	151
Level 1 audit record format.....	151
Preparing an audit trail report	155
Level-2 audit record format	156

Querying a mailbox	157
Chapter 5. Processing batch data using Expedite/CICS	159
Using VSAM data sets as a batch interface	160
Using CICS master terminal commands in a batch interface	160
Sending batch data	160
Receiving batch data	160
Using the MVS internal reader batch interface.....	162
Program A.....	162
Program B.....	162
Using the Expedite/CICS batch send interface.....	164
Batch send I/O	164
Batch send invocation.....	164
Batch send keywords	165
Using batch send processing.....	167
Processing batch send data.....	167
Using Expedite/CICS batch receive interface.....	170
Batch receive invocation.....	170
Batch-receive processing	171
Job output.....	175
Chapter 6. Using Expedite/CICS commands in your application	177
Using copybooks.....	177
Pass-through commands	178
Command responses	178
Alias Inquiry command	179
Alias Inquiry command COMMAREA format.....	179
Alias Inquiry response	180
Archive Retrieve pass-through command.....	182
Archive Retrieve command COMMAREA format	182
Archive Retrieve command temporary storage queue format.....	182
Archive Retrieve response	183
Audit Retrieve command.....	185
Audit Retrieve command COMMAREA format	185
Audit Retrieve response	188
Browse Library Member.....	190
Browse Library Member response.....	191
Cancel pass-through command.....	192
Cancel command COMMAREA format.....	192
Cancel command temporary storage queue format.....	192
Cancel command response.....	196
Define Alias command	197
Define Alias command COMMAREA format.....	197
Define Alias Entry (temporary storage queue input)	199
Define Alias response	200
Define Library command.....	201
Define Library command COMMAREA format	201
Define Library response.....	204
Delete Library command	205
Delete Library response	206
Delete Library Member command.....	207
Delete Library Member response.....	208
Library PutMember command.....	209
Library PutMember response.....	212
Library Search command.....	214
Library Search response.....	216
List Define command	217
List Define command COMMAREA format.....	218

List Define response	221
List Library command	222
List Library response	223
Library Entry Item Structure	224
List Library Member command	227
List Library Member response	228
Library Member List Entry	228
List Verify command	230
List Verify command COMMAREA format	230
List Verify response	232
Load Test Messages pass-through command	233
Load Test Messages command COMMAREA format	233
Load Test Messages command temporary storage queue format	233
Message Inquiry pass-through command	235
Message Inquiry command COMMAREA format	235
Message Inquiry command temporary storage queue format	236
Message Inquiry response	236
Message Queue Query command	239
Message Queue Query response	240
Message Queue Entry	241
Probe command	245
Probe command COMMAREA format	245
Asynchronous Probe response	248
Synchronous Probe response	249
Purge Message command	251
Purge Message response	252
Receive Message command	253
Receive Message command COMMAREA format	253
Receive Message response	260
Received Message header	261
Retrieve Library Member command	268
Retrieve Library Member response	271
Retrieve Library Member CDH command	272
Retrieve Library Member CDH response	273
Send file command	274
Send File command COMMAREA format	274
Send File response	282
Session End command	285
Session End command COMMAREA format	285
Session End response	287
Session Inquiry command	288
Session Inquiry command COMMAREA format	288
Session Inquiry response	289
Session Start command	294
Session Start command COMMAREA format	294
Session Start response	298
Set Administrative Response File command	302
Set Administrative Response File response	304
Chapter 7. Diagnosing and solving problems	305
Solving Information Exchange session start problems	305
Solving session access key problems	307
Restarting a session	308
Reset a user session	308
Solving LU 6.2 connection problems	311
Solving LU 6.2 session check problems	312
Solving common problems	313

LU 6.2 connection problems	313
TCP/IP connection problems	314
Session start problems.....	315
Receive data problems	316
Send data problems	321
Compression problems.....	324
Miscellaneous problems.....	324
Checking data sets and programs.....	326
Determining the status of VSAM data sets	326
Determining the status of destination data sets	326
Determining the status of Expedite/CICS program definitions.....	327
Recovering undeliverable messages	328
Recovering undeliverable messages with an online application	328
Recovering undeliverable messages with a batch procedure	329
Using Expedite/CICS problem determination facilities.....	331
Internal trace queues	331
Trace elements	332
Sample trace messages.....	335
Log TDQ (EXPL)	346
Exception reporting TDQ (EXPM).....	347
TCP/IP error reporting TDQ (EXPT)	347
Appendix A. Understanding automated restart and recovery	349
Initializing the system.....	350
Starting or restarting user sessions.....	350
Monitoring the system	350
Staying synchronized.....	351
Understanding restart and recovery options	352
Appendix B. Sample Programs	353
Finding Expedite/CICS sample programs	354
Appendix C. Using data compression	357
Understanding the Comm-Press programs and files used with Expedite/CICS	357
Files that can be used as input to data compression.....	358
Files that can be used as output from the decompression program.....	358
Other considerations when receiving compressed data	359
The Lookup Table—EXPDLKP.....	359
Glossary	361
Index.....	367



To the reader

This book gives you the information necessary to customize, support, and develop applications using Expedite/CICS, a communication package that runs in the OS/390 environment.

Who should read this book

This book is intended for CICS programmers who want to write application programs that will use Expedite/CICS to communicate with Information Exchange. It also provides a reference for those who have Expedite/CICS support responsibility.

How to use this book

To use this book effectively, it is necessary to understand the following type conventions. In step-by-step procedures, information that you type is shown in boldface type. For example:

At the prompt, type **LG01**

Other type conventions are as follows:

Item	Convention	Example
Command, descriptive name	Initial caps	Session Start command
Command, actual name	SMALL UPPERCASE LETTERS	SDISSTA
Fields	Boldface	Expand
Default values in command formats	Underline	The default is <u>blank</u>
Field values and parameter variables in command formats	Italics	Valid field values are <i>G, P</i> and blank
Words in Glossary, first time used in body text	Italics	<i>Asynchronous</i>

NOTE: When blank is listed as a value, it refers to a blank space, and not the actual typed word.

All terms included in the glossary are shown in italics at their first occurrence in the text of this book.

Acronyms and other notation conventions

Each item listed below is defined in the glossary. If the item is unfamiliar to you, you may want to look it up before you begin.

- **DCT** Destination control table
- **ESD** Electronic service delivery
- **FCT** File control table
- **PCT** Program control table
- **PLT** Program list table
- **PPT** Processing program table
- **PTF** Program temporary fix
- **TCT** Terminal control table
- **TDQ** Transient data queue
- **TSQ** Temporary storage queue

A shortened notation is sometimes used for identifying an account ID and user ID; for example, an account ID and user ID are indicated in both of the following notations:

Account/UseridI : Indicates an unspecified account ID and user ID.

SYSTEM* *ERRMSG: Indicates a specific account ID (*SYSTEM*) and user ID (*ERRMSG*).

To enhance document usability, some examples have been modified and may not appear exactly the same as they are in the product.

You can use uppercase and lowercase letters when typing commands and parameters.

Related Expedite/CICS books

The following books contain information related to the topics covered in this book. For your convenience, these topics can be viewed at: http://www.gxsolc.com/edi_bes.html.

- *Expedite/CICS Display Application User's Guide*, GC34-3303, describes the panels, functions, and features of the Expedite/CICS Display Application for people who use Expedite/CICS and Information Exchange to communicate electronically with business associates. This book is also for administration and support personnel who plan to use the display application to perform administrative functions.
- *Expedite/CICS Program Directory* provides instructions for installing Expedite/CICS on your CICS system.

- *Expedite/CICS Messages*, GC34-233 1, explains the Expedite/CICS messages that are used to communicate processing errors and information. Each entry includes the complete text of the message and any actions you can take to resolve the error.
- *Information Exchange Administration Services User's Guide*, GC34-222 1, provides step-by-step procedures for performing Information Exchange administrative tasks (define users and trading partners, view mailboxes, and so on). It is for Information Exchange service administrators responsible for coordinating the use of Information Exchange in their companies.
- *Information Exchange Interface Programming Guide*, GC34-2222, describes the programming interface Expedite/CICS uses to communicate with Information Exchange. This technical reference also provides information about accessing and controlling an Information Exchange session and how to transfer data.
- *Information Exchange Programming Messages and Formats*, GC34-2324, provides response codes and messages that may occur while programming Information Exchange interfaces. This book is useful in correcting programming errors during development and in performing other problem determination tasks.

Other related books

- *CICS/ESA 4.1 Application Programming Guide*, SC33-1 169
- *CICS for MVS/ESA 4.1 Application Programming Reference*, SC33-1 170
- *CICS for MVS/ESA 4.1 Resource Definition Guide*, SC33-1 166
- *MVS/ESA SP V4 JCL Reference*, GC28-1654
- *MVS/ESA SP V5 JCL Reference*, GC28-1479
- *Introducing EDI Services*, GC34-22 11
- *Information Exchange Administration Mailbox Command Reference*, GC34-2260
- *Network Services Planning Guide*, GC34-2232
- *IP CICS Sockets Guide*, SC3 1-8518

Changes in Expedite/CICS Version 4 Release 5

- TCP/IP capabilities in addition to SNA capability
- X12 support for S3S and S4S security data segments
- IDLT clean-up automatically performed when `irecords-only` are deleted
- User class field added to Send Message panel. If user class is not specified, a default of FFMSG001 will be used.

Introducing Information Exchange and Expedite/CICS

This chapter provides an overview of how Information Exchange and Expedite/CICS work together. The major topics are listed below:

Understanding Information Exchange	2
Using Information Exchange communications	3
Using Expedite/CICS to communicate with Information Exchange	4
Managing data	11
Receiving acknowledgments	13
Using problem determination tools	14
Important files in Expedite/CICS	15
Providing security	16

Understanding Information Exchange

Information Exchange, the EDI Services mailbox component, is an electronic data storage and retrieval service that enables you to exchange messages, documents, and other data with your business associates. Information Exchange is an intermediate system that enables communication between dissimilar computer systems. Information Exchange stores a message in a message database from one user until the recipient, who may be logged on a separate Information Exchange system, is ready to receive it. When the recipient asks to receive messages, Information Exchange transmits them according to instructions provided by the user's receive application.

Information Exchange controls communication through commands that are summarized below.

Column	Description
Alias Inquiry	View the information in an existing alias table
Audit Browse	Retrieve audit information regarding message flow.
Cancel	Cancel messages
Commit	Receive checkpoint messages from a specified Information Exchange address.
Define Alias	Define a nickname that corresponds to an Information Exchange address.
Inquiries	Get information about the status of messages or an Information Exchange session.
Library	Get information about the status of messages or an Information Exchange session.
List Define List	Define a list of Information Exchange users.
Verify	Verify that each user in a list is known to Information Exchange.
Load Test Messages	Load Information Exchange messages provided to test your application.
Probe	Determine if intended destinations are valid for sending messages with a particular payment method or authorization level, or if the address itself is valid.
Purge Message	Purge messages from your mailbox without receiving them.
Queries	Request information about a specific query (for example, an Archive Query or Message Queue Query).
Receive Message	Receive a message sent by another user or users.
Retrievals	Move information, such as archived messages, audit information, session traces, and library members, into your Information Exchange mailbox.
Send Message	Send a message to another user or users.
Session End	End your Information Exchange session.
Session Start	Start an Information Exchange session.

Using Information Exchange communications

A unit of information (mail) sent from one Information Exchange user to another can be a short-message or an entire file of data. Information Exchange stores mail in a database and, when the recipient is ready, transmits the mail according to instructions specified by the receiver's application.

The network assigns each Information Exchange user a unique address consisting of an account ID and a user ID. This is the address of the user's Information Exchange mailbox. The time you spend communicating with an Information Exchange address is called a session. You start a session by issuing a Session Start command that identifies you to the system by your Information Exchange address. Issuing the Session Start command is automatic when using the Expedite/CICS Display Application logon panel. When an Information Exchange session is started, the account ID and user ID provided by the user is then used in all subsequent commands issued to Information Exchange during that session.

In some commands, another user's address is included; for example:

- To send data to a trading partner, you must include the address of that trading partner in the Send Message command.
- To receive data that was sent by a specific user to your Information Exchange mailbox, you can include the address of that user in the Receive Message command.
- To communicate with a trading partner using electronic data interchange (EDI) addresses, you use the Expedite/CICS translate table and Information Exchange alias tables to translate the EDI addresses into Information Exchange addresses.

You can establish concurrent sessions with different mailboxes and, within each session, you can issue multiple Send and Receive Message commands.

Before you continue, you should know that there are references in this book to Information

Exchange Administration Services and supporting documentation. Information Exchange Administration Services is an Information Exchange application that is used to help you organize Information Exchange within your company. Information Exchange Administration Services is used to manage Information Exchange account and user profiles, charge options, trading partners, distribution lists, and alias tables. It also includes features such as audit trails, session traces, and functions for managing mail and library features. You can refer to the *Information Exchange Administration Services User's Guide* for more information about Information Exchange Administration Services or see "Customizing Information Exchange options" on page 48 for information about Information Exchange Administration Services options that affect Expedite/CICS.

Using Expedite/CICS to communicate with Information Exchange

Expedite/CICS is a communications package that runs in the OS/390 environment and is used to exchange electronic data with trading partners by way of Information Exchange. To connect to Information Exchange from Expedite/CICS, you must have an Information Exchange account ID and user ID. Expedite/CICS is used to manage your Information Exchange session; that is, you use Expedite/CICS to give instructions to Information Exchange.

Figure 1 illustrates how your CICS system communicates with Information Exchange using Expedite/CICS.

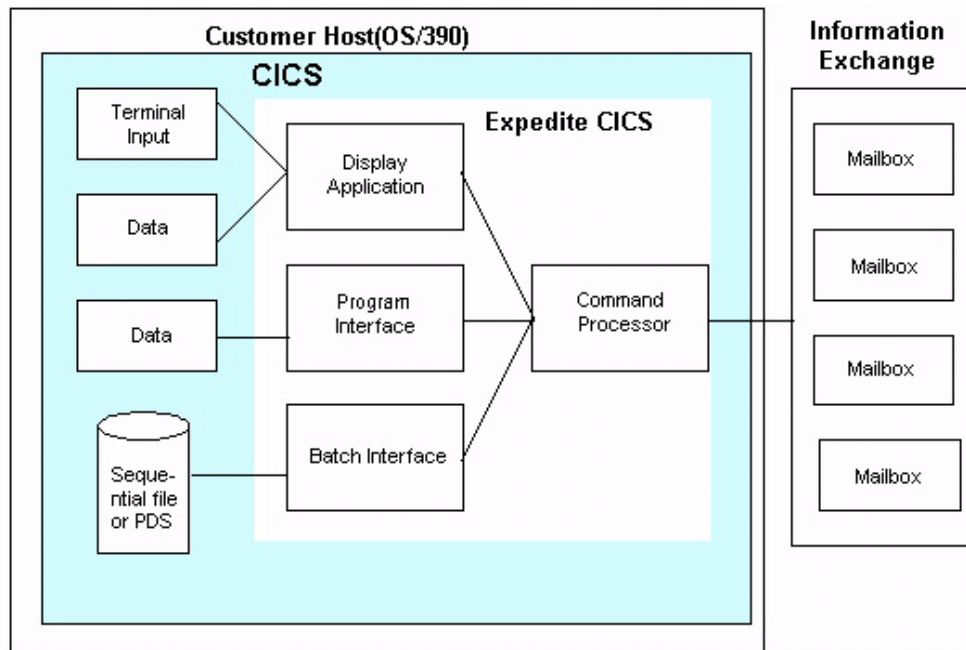

Figure 1. Where Expedite/CICS fits in the Information Exchange picture

Expedite/CICS communicates with Information Exchange through a leased-line LU 6.2 Inter-system communication link or through TCP/IP communication. Commands and messages are sent and received through the communication link in blocks of data ranging from 3700 - 26000 characters. The value used can be set using the Display Application System option.

Major Expedite/CICS components include the following:

- Display Application
- Program Interface
- Command Processor
- Batch Interface
- Activity Monitor (not shown in Figure 1)

Program Interface Overview

The Expedite/CICS display application enables you to send and receive data through Information Exchange as soon as Expedite/CICS is installed on your system. However, your installation may require the send and receive requests be initiated from a user program instead of a terminal. Or you may have a requirement to process the data immediately after it has been received from the Information Exchange mailbox. You can satisfy this requirement by writing your own application programs to interface with Expedite/CICS. The Expedite/CICS Program Interface enables you to:

- Create applications that automatically send and receive data to and from Information Exchange using Expedite/CICS commands.
- Control application communication to Information Exchange and the network.

The Program Interface enables you to write customized and completely automated electronic data exchange applications in CICS. For example, you may have an application that creates purchase orders to be written to a VSAM data set, a transient data queue (TDQ), or a temporary storage queue (TSQ). When a purchase order is ready for delivery to Information Exchange, your application can invoke an Expedite/CICS send file command by linking to the command processor. Your application may send multiple purchase orders (EDI envelopes, for example) within a single message.

You can issue continuous receive requests that link to a program which processes received data whenever messages are received from your Information Exchange mailbox. Continuous receive processing is event driven; an Expedite/CICS transaction is started on your CICS system after completed messages are received into your Information Exchange mailbox. A continuous receive request remains active until ended by a user or application.

Continuous receive requests can be used to select subsets of data from a mailbox, based upon criteria such as user message class. Multiple continuous receive requests can be issued against the same mailbox.

Display Application Overview

The Display Application is provided to help you tailor and use Expedite/CICS. The Display Application is a panel-driven interactive application that enables you to perform the tasks described in this overview.



NOTE: After Expedite/CICS is installed, you can continue to use the Display Application or you can create your own application to automatically link to Expedite/CICS to communicate with Information Exchange.

General session and communication tasks

As a user, you can perform the tasks listed below.

- Start, restart, or end an Information Exchange session using Expedite/CICS.
- Send messages and files to Information Exchange.
- Receive messages and files from Information Exchange either as a single request or by using a continuous receive request.
- Query your Information Exchange mailbox.

- View the status of Expedite/CICS in-process and completed send and receive requests.
- View the status of your session and reset if necessary.
- Work with temporary distribution lists (create, verify, and inquire).
- Verify destination addresses by issuing a probe command.
- Retrieve audit information into your mailbox.
- View log trace alerts.
- Issue Expedite/CICS pass-through commands to Information Exchange.
- Return to CICS temporarily, without ending your Information Exchange session.
- Use batch receive and electronic service delivery functions.
- Define and view your user administration profile that identifies user session options between Expedite/CICS and Information Exchange.
- Define alias tables.
- View information in existing alias tables.

General library tasks

Depending on Information Exchange and Expedite/CICS authorizations, you can perform the tasks listed below.

- Add, change, and delete libraries and library members.
- Retrieve library members.
- Search libraries for text strings.
- View a list of libraries.
- View a list of library members and library member text.

System administration tasks

If you are a system administrator, you can perform the tasks listed previously on behalf of any user and can also do the following:

- Define and view user and system administration options.
- Add, change, or delete user session profiles that identify user session options for all users.
- Define EDI translate table definitions that correlate EDI addresses to Information Exchange addresses.
- Set alternate transaction names.
- List user session status and reset user sessions for all users.
- View the status of messages for another user.
- Define problem determination trace options.

Command processor overview

The Expedite/CICS command processor processes all commands sent to Information Exchange. The command processor receives input from one of the sources shown in Figure 1 on page 4, reformats the input into the proper Information Exchange format, and forwards the reformatted command to Information Exchange. Expedite/CICS provides a single path into the command processor through which your application, or the Expedite/CICS Display Application, passes all commands.

The command processor supports most Information Exchange commands published and supported in the *Information Exchange Interface Programming Guide*. The commands are either

directly supported by the Expedite/CICS command processor or through the Expedite/CICS pass-through facility as shown in the following table.:

Table 1. Session Start command COMMAEA parameters

Command	Description	Command Processor Support
EXPADMN	Set Administrative Response File	No. EXPADMN is an Expedite/CICS command only; it does not have an associated Information Exchange command.
EXPPUTM	Library PutMember	Yes. Expedite/CICS converts EXPPUTM commands to Information Exchange SDISNDM commands.
EXPSNDF	Send File	Yes. Expedite/CICS converts EXPSNDF commands to Information Exchange SDISNDM commands.
SDIARTV	Archive Retrieve	Pass-through only
SDIAUDR	Audit Retrieve	Yes
SDICNCL	Cancel	Pass-through only
SDIDALS	Define Alias	Yes, see Note
SDIINQA	Alias Inquiry	Yes, see Note
SDIINQM	Message Inquiry	Pass-through only
SDIINQS	Session Inquiry	Yes
SDILBRW	Browse Library	Yes
SDILCDH	Retrieve Library Member CDH	Yes
SDILDEF	Define Library	Yes
SDILDEL	Define Library	Yes
SDILDLM	Delete Library Member	Yes
SDILLIST	List Library	Yes
SDILMBR	Library Member List	Yes

Table 1. Session Start command COMMAEA parameters

Command	Description	Command Processor Support
SDILRTV	Retrieve Library Member	Yes
SDILSCH	Library Search List	Yes
SDILSTD	Define	Yes
SDILSTV	List Verify	Yes
SDILIST	Load Test Messages	Pass-through only
SDIPRGM	Purge Message	Yes
SDIPROB	Probe	Yes
SDIQUMS	Message Queue Query	Yes
SDIRCVM	Receive Message	Yes
SDISEND	Session End	Yes
SDISSTA	Session Start	Yes
SDITRLB	Session Trace Browse	Pass-through only
SDITRLR	Session Trace Retrieve	Pass-through only



NOTE: The Alias Inquiry (SDIINQA) and Define Alias (SDIDALS) commands are supported by the command processor, and can be issued from the Display Application. Because this was not true in earlier Expedite/CICS versions, provision has been made so these commands can still be issued using the Pass-through option. Existing applications that use them this way are not affected.

Expedite/CICS communication area (COMMAREA)

The data structure used to pass information from an application to the command processor is called the communication area, usually referred to as the COMMAREA. Data required to format an Expedite/CICS command is placed in the COMMAREA, and the EXEC CICS LINK command is used to transfer program control to the command processor. The command processor returns a response to the calling program, whether that program is the Display Application or a user application.

Receiving data from Information Exchange

Expedite/CICS provides two types of Receive Message commands to tell the command processor to receive data from an Information Exchange mailbox:

- **Single Receive:** receives all items in the mailbox that meet the receive criteria at the time of issue. The request terminates when the receive is complete.
- **Continuous Receive:** also receives all items from the mailbox that meet the receive criteria at the time of issue, but remains active after all mail in the mailbox is processed and continues to receive new mail as it arrives in the Information Exchange mailbox.

An application can receive the following Information Exchange responses and messages:

- Immediate responses, resulting from response-oriented commands issued to Information Exchange.
- Mailbox responses, resulting from commands issued to Information Exchange.
- Messages and files, from another Information Exchange user.

Receiving immediate responses:

Information Exchange commands that generate immediate responses to indicate transaction status are called response-oriented commands. For example, when Expedite/CICS sends a Session Start command, Information Exchange immediately returns a Session Start response. A list of all response-oriented commands is provided in the *Information Exchange Interface Programming Guide*. Response-oriented commands you can send to Information Exchange include the following:

- Session Start (SDISSTA)
- Session End (SDISEND)
- Session Inquiry (SDIINQS)
- Define Library (SDILDEF)
- List Library (SDILLST)
- Audit Retrieve (SDIAUDR)

Immediate command responses are returned to your application in the COMMAREA. If your own application issues a command that result in an immediate response, you are responsible for making sure it checks the responses to locate and correct errors. However, if such a command is issued from the Display Application, the Display Application will check the responses and inform you of any problems.

Receiving mailbox responses:

Messages that result from commands are placed in your Information Exchange mailbox and must then be received. Such commands include, but are not limited to, the following:

- Cancel (SDICNCL)
- Probe (SDIPROB)
- List Verify (SDILSTV)
- Retrieve Library Member (SDILRTV)
- Load Test Messages (SDILTST)
- Audit Retrieve (SDIAUDR)

The commands listed above are examples of commands that can result in a response in your mailbox (this does not always occur).

Receiving messages and files:

Messages and files another Information Exchange user sends to you are placed in your Information Exchange mailbox. Your application must issue a Receive Message command to receive these messages and files.

Sending data to Information Exchange

The command processor recognizes the commands listed below as requests to send data to Information Exchange:

Send File (EXPSNDF) sends a file to Information Exchange.

- Library Put Member (EXPPUTM) sends a file to be added as a member of an Information Exchange library. Identifying Information Exchange error messages

Batch Interface Overview

With the Expedite/CICS Batch Interface, you can send data to Information Exchange that was previously created in a batch environment or to receive data from Information Exchange that can be processed later in a batch environment. For more information, see Chapter 5, “Processing batch data using Expedite/CICS.”

Activity monitor overview

Expedite/CICS provides the activity monitor to perform automatic restart and recovery. The activity monitor is a background CICS transaction that runs regardless of the process method used (Display Application, user programs, or batch). It runs periodically based upon the interval specified on the Display Application System Options panel. For more information, see Appendix A, “Understanding automated restart and recovery.”

Managing data

Data type	Description
Other	Defines a logical record as free-format data with no delimiters.

Receiving acknowledgments

Information Exchange acknowledgments are sent from the same address (*SYSTEM*
ERRMSG) as Information Exchange errors. They can be placed in a sender's Information Exchange mailbox at various times during processing; for example, when the message being sent is:

- Received into the mailbox
- Delivered to the recipient destination
- Purged

Other acknowledgment options include:

- Expedite/CICS completion notification, where a notification that a request has completed is received and processed by a user program
- Application acknowledgments, where beginning and ending application programs exchange acknowledgments through Information Exchange to ensure that beginning and ending processes have completed processing.

For more information, see “Understanding acknowledgments” on page 117.

Using problem determination tools

The Expedite/CICS trace facility provides the following trace destinations for problem determination:

- Internal trace temporary storage queues (TSQs), EXPDTRCA and EXPDTRCB, store input and output commands and data.
- Exception reporting transient data queue (TDQ), EXPM, logs only severity 08 or above errors. Your installation may route or process this queue to a destination of your choice. The default destination is to the sequential file EXALERT.
- Log destination transient data queue (TDQ), EXPL, logs system messages and severity 08 or above errors, and, optionally, command traces. The default destination is to the sequential file EXPLOG1. Various information can be written to each trace destination; however, errors are always written to the trace destinations in use.
- TCP/IP error destination log (TDQ), EXPT, logs TCP/IP error messages, severity 08 or above. The default destination is to the sequential file EXPTCPIP. TCP/IP errors resulting from errors calling TCP/IP program EZASOCKET will contain a reason code that must be looked up in the *IP CICS Sockets Guide*.

When developing and testing Expedite/CICS applications, the trace function is useful for tracing Expedite/CICS commands and responses to and from:

- User written applications
- The Display Application
- The Expedite/CICS command processor
- TCP/IP Relay
- Information Exchange

Overall message flow between each of the systems is traced and severe errors are identified. For more information about the trace facility, see “Using Expedite/CICS problem determination facilities” on page 313.

Important files in Expedite/CICS

Because they are regularly used by Expedite/CICS and often discussed, it will help you to be familiar with the files listed below.

File	Description
EXPDERR	Contains records that define some of the Expedite/CICS system options, such as the activity monitor interval. The PLT program EXPOSTRT checks for the existence of these records and, if they are not found, it creates them.
EXPDLKP	Contains the compress lookup table.
EXPDPTF	Synchronizes batch and online CICS operations during processing of batch send and batch receive functions and provides temporary storage when sending batch data. For batch send, this file is closed and opened at intervals corresponding to the value set in the Batch monitor interval field, described in “System option details” on page 27.
EXPDSRC	<p>Contains the following:</p> <ul style="list-style-type: none"> ■ Control records for Send Message and Receive Message commands ■ User profile records ■ Distribution list records ■ Translation records used to resolve EDI addresses ■ JCL used to receive Electronic Service Delivery PTFs
EXPDTST	Tests Expedite/CICS Send File and Receive File functions. This file is optional and is provided for test purposes only.
EXPHPHP	Contains online help text.
EXPRDAT	Contains received data records.
EXPSDAT	Contains send data records.
EXPDKEY	Contains saved unique keys used in verifying the identity of Information Exchange to Expedite/CICS and Expedite/CICS to Information Exchange.

Providing security

The network provides security at the network access level, the application selection level, and the data access level.

Because security features operate within a widely used data processing environment, Information Exchange can protect users only if they observe security controls, including the following:

- Change passwords periodically.
- Use authorization levels to control user access to specific functions.

Extended Security Option

The Extended Security Option (ESO), which may be turned on by an Information Exchange service administrator, provides additional password security. For information on setting ESO, see the *Information Exchange Administration Services User's Guide*.

ESO contains the following security features:

- Your ESO password cannot be the same as your user ID. If either you or an Information Exchange service administrator fails to provide a new password, a session cannot be started with Information Exchange.
- Your ESO password must conform to the rules listed below; otherwise, you will not be able to start a session with Information Exchange. New passwords:
 - Must not contain the user ID as any part
 - Must be at least six characters in length
 - Must contain at least three different characters
 - Must contain a non-numeric first and last character
 - Must contain at least one non-alphabetic character
 - Must contain at least one alphabetic character
 - Must contain only the valid characters A-Z, 0-9, and special characters #, @, and \$
 - Must be different from the current and five previous passwords
 - Must not contain more than two identical consecutive characters
 - Must not contain more than three identical, consecutive characters from the previous passwords
- Information Exchange revokes your ESO user ID if you make three consecutive attempts to start an Information Exchange session with an invalid password. All further attempts to start an Information Exchange session are unsuccessful until your user ID is resumed by your Information Exchange Service Administrator.

Charges

Details of billing should be received from your local representative, as they differ internationally and may change from time to time.

In the United States, customers can select GETINFO from the AT&T Global Services Service Selection Menu for charge information.

Customizing Expedite/ CICS

This chapter discusses general system configuration considerations and provides procedures for customizing the system after the Expedite/CICS installation is complete. The customization tasks should be performed the first time you log on after Expedite/CICS is running. The major topics discussed are listed below:

Performing initial administration tasks	18
Changing the SYSTEM/DEFAULT password	19
Customizing user administration options	22
Customizing system administration options	30
Customizing EDI destination addresses	34
Customizing Expedite/CICS transaction names	43
Customizing trace options	48
Customizing Information Exchange options	53
Customizing Display Application menus	55
Reorganizing system files	57

Performing initial administration tasks

The first time Expedite/CICS starts, user profile SYSTEM/DEFAULT is created with Expedite/ CICS default values; it is assigned Expedite/CICS service administrator authority and the initial password is DEFAULT. This profile is used as a model for all new profiles that will be created.

When Expedite/CICS is running, the primary service administrator should use the Display Application to log on as SYSTEM/DEFAULT and perform the initial administrative functions described in the procedure below.



CAUTION: If you are an experienced CICS user, you are probably ready to proceed. If you are relatively inexperienced, however, refer to the *Expedite/ CICS Display Application User's Guide* and review the "Getting started with Expedite/CICS" and "Leaving Expedite/CICS" sections.

Depending on your experience level and how much time you want to spend, you can do the following:

- To perform preliminary configuration tasks only, refer to the items listed below and save the remaining tasks for later completion.
 - 1) Change the SYSTEM/DEFAULT password as described in "Changing the SYSTEM/DEFAULT password" on page 17.
 - 2) Set the values for the Force user to log on and Auto create user fields as described in "Customizing user administration options" on page 20. These fields should be defined soon after your system is installed; the other fields can be done later at your convenience.
- To complete all customization tasks, complete all procedures provided in this chapter.

Expedite/CICS displays the Information Exchange Session Start Menu.

```
EXPMMN1          Expedite/CICS  Information Exchange Session Start

Account          SYSTEM
Userid           DEFAULT

Current Information Exchange password:

Password         <           >

New password (optional):

New password     <           >

Verify new password <           >

HI209 TYPE YOUR INFORMATION EXCHANGE PASSWORD, THEN PRESS ENTER.

Command ==>>
PF1=Help  PF3=End  PF12=CANCEL
```

7. In the Password field, type DEFAULT.
8. In the New password field, type a new password.
9. In the Verify new password field, type the new password again.
10. Press Enter.

Expedite/CICS displays the Main Selection Menu.

```
EXPMMMS          Expedite/CICS Main Selection Menu

Account          SYSTEM
Userid           DEFAULT

Select the desired function:

   1 RECEive      Work with receive data
   2 SEND         Work with send data
   3 LIBraries   Work with libraries and members
   4 LIST        Work with distribution lists
   5 USERs       Work with user administration
   6 SYStem      Work with system administration
   7 PASs-through Pass-through command(s) to Information Exchange
   8 ALIas       Work with alias tables
   E ESCape      Leave session ACTIVE and return to CICS
   S STArt      Restart session with Information Exchange
   X LOGoff      End session with Information Exchange

HI325 ENTER FUNCTION NUMBER, FIRST 3 LETTERS, OR =#. # ON THE COMMAND LINE.

Command ===>
PF1=Help  PF3=End
```

The SYSTEM/DEFAULT password is now reset, and you are ready to proceed with your customization.

Customizing user administration options

User session options must initially be set using the SYSTEM/DEFAULT ID. After the initial defaults are set, options can be subsequently changed using the SYSTEM/DEFAULT ID or any other service administrator's user ID. To set initial user session defaults, begin on the Expedite/ CICS User Administration Selection menu.

1. Select option 2, **Change an existing user.**

Expedite/CICS displays the Define User Session Options panel. The account ID and user ID are already filled in, together with default values for the SYSTEM/DEFAULT user profile.

```

EXPMADS                    Define User Session Options
For:
  Account   < ACCT   >
  Userid    < USER01 >

OPTIONS:

Force user to logon...< N >      Y - yes  N - no
Auto create user.....< N >      Y - yes  N - no
Type user.....< GA >           GA - General, SA - Service admin
Time zone.....< W0500 >        (See Display Application manual)
Message group size...< 02 >     0 - 99
Auto logon.....< N >          Y - yes  N - no
Send file retention...< 01 >    0 - 30 days
Receive retention...< 01 >    0 - 30 days
Response file
  File name.....< EXPDRE1 >    File or Program name
  File management...< TS >     TS, TD, VS, or PG
  Process send data...< A >    A - Asynchronously  S - Synchronously

HI310 ENTER FIELD INFORMATION, PRESS PF8/PF7, AND PRESS PF3 TO SAVE CHANGES

Command ==>
PF1=Help  PF3=End  PF8=Forward  PF12=Cancel

```

2. Fill in the panel fields as needed. If you need help, see “User administration field descriptions” on page 21.
3. When you have finished typing field entries, do one of the following:
 - To save the default information in the user profile and return to the Expedite/CICS User Administration Selection menu, press PF3.
 - To return to the Expedite/CICS User Administration Selection menu without saving the information you typed, press PF12.

User administration field descriptions

Use the information provided in the topics under this heading to fill in user administration fields as needed.

Force user to log on

Only service administrators can change this option to indicate whether a user, having left Expedite/CICS temporarily using the Escape option, must provide an Information Exchange password and restart the Information Exchange session when re-entering the Display Application.

This code:**Means:**

- N** An Information Exchange password and session start is required only when a session does not exist; if an active session exists, Expedite/ CICS bypasses the Information Exchange Session Start panel and displays the Main Selection menu. The user logs back on to the active session and a session start is not performed. N is the recommended value.
- Y** A password is required and a new session start is always performed during a logon.

When a new session is started, the session access key changes; therefore, Information Exchange archiving of received messages begins under a new group.



CAUTION: If the same user ID starts a session from two systems, the second session overrides the first and Information Exchange communicates with the later session. This may cause a checkpoint failure, because the counters between Expedite/CICS and Information Exchange are not the same. In addition, a session access key error may occur and messages may be delivered to a system other than the one intended. For these reasons, you should not share user IDs across systems.

Auto create user

This field in the user profile is meaningful only for the SYSTEM/DEFAULT model user profile.

This code:**Means:**

- Y** Any valid Information Exchange users can start a session with Information Exchange using Expedite/CICS, whether they already have an Expedite/CICS profile or not. A general user profile will automatically be created for the user ID, using the SYSTEM/DEFAULT model.
- N** Only users defined to Expedite/CICS can start a session with Information Exchange using Expedite/CICS. An Expedite/CICS service administrator must define all Expedite/CICS user profiles using the **Add** option. A user who has no profile will get an error when attempting to sign on to the Display Application or when issuing a Session Start command.



NOTE: The N option can be used to ensure that production IDs are not used in the test region.

Type User

Service administrators can use this field to indicate whether a user is a general user or service administrator; thereby, controlling access to certain system functions.

This code	Indicates this authority
GA	General Users can: <ul style="list-style-type: none">■ Change only their own user profiles■ Perform user session functions only for themselves All automatically created profiles have general user authority by default.
SA	Service administrators can: <ul style="list-style-type: none">■ Change any user's profile.■ Perform all user session functions for any user.■ Change Expedite/CICS system options.



NOTE: It is recommended that the SYSTEM/DEFAULT ID not be set to user type GA (general). The potential would then exist for there to be no service administrators on the system, making it impossible to change any system options.

Time zone

This is a five-character code for your time zone. Table 2 lists the valid time zone codes; the code letter indicates an east or west offset and the number following the letter indicates the number of hours offset from the Greenwich meridian. All full-hour offsets are valid, even if they are not shown below

Table 2. Time zone codes

Time Zone	Description	Time Zone	Description
E1000	Eastern Australia	W0400	U.S. Atlantic Standard
E0900	Japan Standard	W0400	U.S. Eastern Daylight
E0200	Western Europe Daylight	W0500	U.S. Eastern Standard
E0200	Eastern Mediterranean	W0500	U.S. Central Daylight
E0100	British Summer	W0600	U.S. Central Standard
E01 00	Western Europe Standard	W0600	U.S. Mountain Daylight
E0000	Greenwich Mean	W0700	U.S. Mountain Standard
		W0700	U.S. Pacific Daylight
		W0800	U.S. Pacific Standard
		W0800	U.S. Alaska Daylight
		W0900	U.S. Alaska Standard
		W1000	U.S. Hawaii Standard

Message group size

This field applies only to sending data to Information Exchange. Data is sent to Information Exchange in segments, the size of which is set in the Data transmission size field on the Define System Options panel. This value (1 - 99) specifies that data is to be split into groups of the specified size. The Message group size field specifies how many segments are contained in the group when sent to Information Exchange. When segments are grouped, the first segment is sent with a long header and remaining segments are sent with a short header. The data is committed only at the end of the file.

A value of zero indicates no segment grouping and all segments following the first are sent with a short header. A value from 1 to 99 specifies that data is to be split into groups of a specified size. For example, if Data transmission size is set to 26,000 bytes and Message group size is set to 02, data is sent in groups of segments (called messages) of 52,000-bytes; the long header occurs after every second segment.

Message grouping is important for receiving systems using checkpoint-level recovery, such as a PC interface. A checkpoint commit is taken for each group of segments.

If transmission size is set lower than 26,000 bytes, receiving systems might experience an increased number of checkpoints. In these cases, you may want to increase the message group size.

Auto logon

The value specified determines if an Information Exchange session is automatically started for the user when the CICS region starts.

This code	Tells Expedite/CICS to:
N	Not automatically start an Information Exchange session when the CICS region starts, unless the user was in active session with Information Exchange when the system went down.
Y	Automatically start an Information Exchange session each time the CICS region starts.

Send file retention

The value in this field specifies how long Expedite/CICS should save send control records associated with successfully sent data. This value can range from zero to 30 days; the default is one day. Retention applies only to records associated with successfully completed requests, not requests that encountered an error or have a status of HELD. Expired records are periodically deleted by the activity monitor when it runs, as set in the system options profile.

Control and data records NOT associated with successfully sent data (for example, E-HIxxx and HELD) are purged by Expedite/CICS after the number of days specified in the Not-Sent Not-Received Retention parameter on the Define System Options panel, unless purged sooner by the user.

To avoid peak processing times, Expedite/CICS will not purge records between the time specified on the Define System Options panel.

Receive retention

The value in this field specifies how long Expedite/CICS should save receive control records associated with successfully received data. This value may range from zero to 30 days; the default is one day. Retention applies only to records associated with successfully completed requests, not requests that encountered an error or have a status of HELD. Expired records are periodically deleted by the activity monitor when it runs, as set in the system options profile.

Control and data records not associated with successfully received data; for example, E-HIxxx, HELD, and COMPLETE, are purged by Expedite/CICS after the number of days specified in the Not-Sent Not-Received Retention parameter in the Define System Options panel.

To avoid peak processing times, Expedite/CICS will not purge records between the times specified on the Define System Options panel.

Response file name

Type the name of a file or program to use for storing or processing Information Exchange system messages. The default storage facility is TSQ, EXPDRE1. The value in this field names either the CICS storage facility in which data is stored, or a program to be invoked when you receive Information Exchange system messages. Messages from the following IDs will be written to the response file:

```
*SYSTEM* *ADMIN*           *SYSTEM* *LSTRSP*
*SYSTEM* ADMINGET         *SYSTEM* *PRBRSP*
*SYSTEM* *ERRMSG*        *SYSTEM*
*TSTMSG* *SYSTEM* *EVENTS*
```

A message from *SYSTEM* *ERRMSG* may be a system error message or an Information Exchange acknowledgment.



NOTE:

1. Except for audit trails, system messages are written to the administrative response file. If the **Retain header data** field has been specified in the receive request, header data for system messages will also be written to the destination specified on the receive panel. Although audit trails are system messages, Expedite/CICS does not write them to the administrative response file, but writes them to the destination file specified on the receive request.
2. The data set should handle variable length records up to a maximum of 26,000 bytes.
3. The response file definition that is set in a user profile is the permanent response destination. If changed, the new value will not be recognized until a session start is issued. To change the response file destination for the duration of a session, you can change the value in the **Set response file destination** field on the Expedite/CICS User Administration Selection menu. If the response file name is changed, the following considerations apply:
 - If using a VSAM file, the file name must be defined in the CICS FCT.
 - If using a TDQ, the file name must be defined in the CICS destination control table (DCT) and, if it is an extrapartition TDQ, it must also be defined in the CICS startup JCL.
 - If the **File name** field contains a program name, instead of a file name, the program must be defined in the processing program table (PPT).
 - A nonrecoverable TSQ need not be defined.

Response file management

The value in this field indicates the type of destination in which received Information Exchange system messages are stored

This code	Describes this type of field
TS	Temporary storage (default)
TD	Transient data
VS	VSAM ESDS (entry sequenced data set) only
PG	A user program



NOTE: If you select the wrong file management type, an error may occur when Expedite/CICS writes the data to that destination. If this occurs, an error message is written to the exception log.

Process send data

Data is always sent using the Group level commit method of recovery in which data is committed only at the end of the message group. The value in this field indicates whether Expedite/CICS should process send request data synchronously or asynchronously.

This code**A****Specifies**

Asynchronous processing

When Expedite/CICS processes asynchronously, it reads the data to be sent, reblocks it into the send data (EXPSDAT) file, and returns control to the Display Application or user program. Another Expedite/CICS task is started that sends the data to Information Exchange.

Asynchronous processing can enhance performance and recoverability because:

- Communication and commits with Information Exchange are done in the background.
- Your CICS session is free to issue additional requests. Because control is returned to you before data is actually sent to Information Exchange, you can issue multiple send requests, which Expedite/CICS queues and sends to Information Exchange in turn.
- Expedite/CICS initiates restart and recovery procedures to automatically reacquire connections and restart sessions until the connection is made and communication is successful.

If a communication link failure and subsequent recovery occurs, Expedite/CICS retries the send request until the file is sent successfully. If there is an unrecoverable error, the message is marked in error and can be viewed as explained in the *Expedite/CICS Display Application User's Guide*. Errors are also logged in the Expedite/CICS trace destinations, including the exception log.

If you issue a request from a user program, you can specify the name of a user exit that will be invoked when asynchronous send requests actually complete.

S

Synchronous processing. Control is not returned to the requester until the data has been sent to Information Exchange.

When Expedite/CICS processes synchronously, it reads the data to be sent, reblocks it into the send data (EXPSDAT) file, and sends it to Information Exchange. The Display Application (or user program if using the programming interface) waits until the file is sent to Information Exchange before getting a return code, or freeing up the terminal for another request. If a communication link failure or unrecoverable error occurs, the message is marked in error and the data is purged from the EXPSDAT file. The error code can be viewed as explained in the *Expedite/CICS Display Application User's Guide* or, if a user program is used, an error is returned to a user program.

The user (or user program) is then responsible for reissuing the send request. This strategy results in decreased system performance.

Customizing system administration options

System options on the Expedite/CICS System Administration Selection menu is provided to help you customize your Expedite/CICS system. If you are a service administrator, you can customize system default values for your organization. If you are a general user, you can view the options.

To view or define system-wide options, begin on the Expedite/CICS System Administration Selection menu.

1. Select option 2, **System options**. Expedite/CICS displays the Define System Options panel, with your account ID, user ID, and system (default and current) options already filled in.

Account		ACCT	Default Value	Current Value
Userid	USERID			
EXPMD9			Define System Options	
			< S@# >	< S@# >
			< EXPM >	< EXPM >
		(0500-5959)	< 3000 >	(MMSS) < 0500 >
		(0000-5959)	< 0000 >	(MMSS) < 0100 >
		(03700-26000)	< 26000 >	< 26000 >
			< EXPOUEXT >	< EXPOUEXT >
		(Y=Yes, N=No)	< N >	< N >
			< IRDR >	< IRDR >
			< EXPL >	< EXPL >
			< EXPDTRCA/B >	< EXPDTRCA/B >
			< INIE >	< INIE >
			< 4.05 >	< 4.05 >
		(0100-2359)	< 0500 >	(HHMM) < 0500 >
			< 40 >	(1-40 Days) < 40 >
			< 0800 - 1600 >	< 0800 - 1600 >
HI305 ENTER FIELD INFORMATION AND PRESS PF3(END) TO SAVE CHANGES.				
Command ==>				
PF1=Help PF3=End PF12=Cancel				

2. To change system defaults, refer to “System option details” below, as needed, and then type new values over the displayed current values.
3. To discard changes and return to the Expedite/CICS System Administration Selection menu, press PF12.
4. To save changes and return to the Expedite/CICS System Administration Selection menu, press PF3.

System option details

The topics under this heading provide information about which system options may be changed, which are protected, and other pertinent details.

Temporary storage queue (TSQ) prefix (S@#)

While running, Expedite/CICS uses a number of temporary storage queues with a naming prefix default of S@#. You can change the prefix default if, for example, the default characters conflict with what you already use in your system. When changed, the new prefix takes effect immediately. The rules on the following page apply.

- N may not be used as the first character.
- The first character cannot be numeric.
- All three characters must be entered and no blanks are allowed.

Exception reporting TDQ (EXPM)

EXPM is provided, in addition to the Log TDQ (EXPL), to alert systems support personnel to error conditions that interrupt continuous operations and, therefore, might require attention. The name of this queue can be changed in accordance with information provided in “Exception reporting TDQ (EXPM)” on page 329.

Activity monitor interval

The activity monitor is an Expedite/CICS transaction that runs periodically to perform various tasks, described in Appendix A, “Understanding automated restart and recovery.” The value in this field determines how often the activity monitor runs. Because it performs many important Expedite/CICS functions, you cannot disable the activity monitor. The field format is MMSS, and valid values range from 0500 - 5959. The default is 3000.

When changed, a new interval takes effect the next time the activity monitor transaction runs.

Batch monitor interval

The Batch Send function is controlled by an Expedite/CICS transaction that runs at periodic intervals to determine if there is batch data to send. If there is data to send, the task starts the background send process in the Expedite/CICS command processor. The field format is MMSS, and valid values range from 0000 - 5959. The default value 0000 disables the Batch Send function.

When changed, the new interval takes effect the next time the Batch Send transaction runs; this happens immediately after changing the value. If you use Batch Send, the recommended interval value is 0015.

Data transmission size

Expedite/CICS data exchanged with Information Exchange is sent or received in segments, the size of which is determined by the value in this field, not by the value in a user's profile.

Send and receive data segment size can range from 3,700 to 26,000 bytes. The default is 26,000 bytes or the maximum segment size identified by your Information Exchange system. If changed, the new value takes effect only after a subsequent Information Exchange session start.

User information exit program name (EXPOUEXT)

The value in this field names a program you want to use to log information about asynchronous send request and receive request processing:

- The send function links to the exit after data is sent to Information Exchange.
- The receive function links to the exit after writing the received data into the receive destination.

If you do not want to use the user information monitor exit program, enter N in the User exit active field. If changed, a new exit name takes effect as soon as the panel is saved (assuming the User exit active field is set to Y). The first character cannot be numeric, and no embedded blanks are allowed.

User exit active

The value in this field determines whether or not a link to the user information exit program is enabled.

This code	Indicates this status
N	Expedite/CICS link to the user exit program is disabled.
Y	Expedite/CICS link to the user exit program is enabled.

Internal reader TDQ (IRDR, protected)

The value in this field names the TDQ that defines the internal reader. Expedite/CICS MVS batch receive and Electronic Service Delivery (ESD) receive functions require JCL to be written to the MVS internal reader in order to submit a job to MVS. Although the name for the TDQ is protected, you can use another name as the DSCNAME in the DCT. This requires an entry in the CICS JCL where the internal reader is defined. The suggested name is BTCHRDR. This extra-partition TDQ must be defined in the destination control table (DCT). Changes to the DCT are not recognized until the CICS region is recycled. For more information about this definition, see the *Expedite/CICS Program Directory*.

Log TDQ (EXPL, protected)

The value in this field names the TDQ to which all error and informational messages are written. Information and error messages are always written to this queue; on the other hand, Expedite/ CICS commands, responses, and data are optionally traced based on values specified on the Trace Options panel.

This can be helpful during problem determination when the system needs to be traced for long periods of time.



NOTE:

1. This extrapartition TDQ must be defined in the destination control table (DCT). Changes to the DCT are not recognized until the CICS region is recycled.
2. For more information about EXPL definition, see “Log TDQ (EXPL)” on page 329.

Internal trace TSQs (EXPDTRCA/B, protected)

Two temporary storage queues (TSQs) are used with the Expedite/CICS internal trace. Expedite/ CICS writes to one of these TSQs until the number of records specified on the Trace Options panel is reached, then switches to the other TSQ. When the second TSQ contains that same number of records, Expedite/CICS deletes the data in the first TSQ and switches back. The value in this field names the TSQs to which trace information is written.



NOTE: No definition is required for the internal trace TSQs, because they are created dynamically, as needed. For more information about the internal trace TSQs, see “Internal trace queues” on page 313.

LU 6.2 Information Exchange connection name (INIE, protected)

This is the connection name used by Expedite/CICS when communicating with Information Exchange. This should be defined in the terminal control table (TCT) definitions for the connection and sessions to Information Exchange. For more information about this definition, see the *Expedite/CICS Program Directory*.

Information Exchange level (protected)

This is the version and release level of the Information Exchange system to which Expedite/ CICS is connected.

Force purge/release time

The value in this field determines how soon after a receive data record has become stuck that it can be purged or released. If you are a system administrator, after this amount of time has elapsed, you can purge an incomplete receive data record or release a complete receive data record.

The field format is HHMM, and valid values range from 0100 to 2359. The default is 0500 (5 hours).

Not-Sent Not-Received retention

The value of this field determines how soon send and receive control and data records will be purged by the activity monitor if they did not complete successfully. After the specified period, the activity monitor will purge send control records with a status of E-HIxxx or HELD as well as receive control records with a status of E-HIxxx, HELD, or COMPLETE. All associated records with the send or receive are deleted.

The value can range from 01 to 40 days. The default is 40 days.

Sent/Receive non-delete window

On a system-wide basis, the System Administrator can set the times outside of which RC records with a status of RECEIVED, and SC records with a status of SENT, will be deleted. Customers upgrading from a previous release must update this field manually. If the default field is left blank or has invalid characters, a default value of 8 a.m. to 4 p.m. is applied. This field is initialized during first time installation when the customer defines the EXPDERR data set.

The field format is HHMM to HHMM, and valid values range from 0000 to 2359. The default is 0800 to 1600 (8 a.m. to 4 p.m.).

Customizing EDI destination addresses

Before you send EDI data to Information Exchange, you must define the destination address in the Expedite/CICS EDI translate table, which converts EDI destination addresses to Information Exchange destination addresses. This table is used whenever you send data and specify File type = E (EDI). The destination address is always taken from the EDI data fields; therefore, when you are sending EDI data, leave the Account/Userid fields blank.

The DATatypes option on the Expedite/CICS System Administration Selection menu provides access to the translate table. You can use the SYSTEM/DEFAULT ID (if you are a service administrator, your own user ID) to add, change, and delete table entries. If you are a general user, you can only view the table.

The EDI destination field defines where you want to send the data. This can be any of the following:

- A real Information Exchange account ID and user ID



NOTE: System ID is optional for EDIFACT and UN/TDI data.

- A distribution list
- A nickname in Expedite/CICS that can be resolved into an Information Exchange destination address by using the translate table. This resolved destination can be an Information Exchange:
 - Account ID and user ID on the local system
 - Account ID and user ID on another system
 - Alias name defined in a centralized Information Exchange alias table
 - Destination information in the EDI data is parsed into fields that are used to determine the Information Exchange destination of the data. When you send an EDI file and specify File type = E (EDI), Expedite/CICS compares the data fields to entries in the EDI translate table and uses the EDI data type and other information found in the table to determine the Information Exchange destination.



NOTE: For X12, EDIFACT, and UN/TDI data, a real Information Exchange destination can be placed in the data. For EDIFACT and UN/TDI data, this is a system ID, account ID, and user ID. For X12 data, this is just account ID and user ID. For X12 and EDIFACT data, a special data type qualifier (ZZ) can be used to indicate this fact so that, if no entry is found in the translate table, the Information Exchange destination in the EDI data can be used as the actual Information Exchange destination. For UN/ TDI data, the ZZ qualifier is not used, but a different method is used.

Translate table entries are used to resolve destinations for specific EDI data types, EDI qualifiers, and the EDI nickname from the EDI data. A variable default can be set for any of these fields by leaving that EDI translate table field blank. A blank entry equates to any value for this field. When the translate table is searched, if an entry is found that matches the EDI destination information in the EDI data, that entry is used. If no matching entry is found, but EDI destination field default entries match those in the data, the data will be sent to this default destination. Default entries are searched in order, according to the number of blank (default) fields; that is, default entries with one blank field will be searched before default entries with two blank fields, and so on.

For more information about the translate table and how EDI processing works, see “Processing EDI data” on page 83 and “Processing EDI receive data” on page 102.

Table 3 shows the EDI and Information Exchange components that are defined in the table and used in conversion routines.

Table 3. EDI translate table components

EDI Address Components		Information Exchange Address Components	
Type	Defines data type	Type	Defines the alias table type, or indicates a list
Qualifier	Defines the conversion program	ID	Indicates the alias table name
Nickname	Defines EDI destination	Account	Account ID or list name
		User id	User ID



NOTE: The account ID and user ID fields can be used together to specify an alias name. The alias table type and table ID fields can be used to specify an intersystem identifier. The account ID and user ID fields must be blank if you want to reference a distribution list.

To work with the EDI translate table, begin on the Administration Services Selection Menu.

1. Select option 1, **Formatted data translation table**. Expedite/CICS displays the EDI Translate table. The left half of the panel is used for EDI destination addresses; the right half is used for Information Exchange addresses.

```

EXPMTT1          EDI Translate table          Page 01 of 01

          EDI                                Information Network
    Destination address                    Information Exchange address
Type Qualifier  Nickname                    Type  ID  Account  Userid
   08          EDIDEST                       L
   ZZ          EDITEST.USER01
T    ZZ          EDITEST                       ACCOUNT2  USER02
X    02          TP909                         G    ALL
T    ABCD        ALIAS1                       P    ABC
U    01          ALIAS2                       I    EUR  ACCOUNT1  USER01
   12          TP007                         P    ABC  ANIBALIA  SNAME

Enter a "D" in the data type field to delete an entry.
HI315 ENTER TRANSLATE TABLE ENTRIES AND PRESS PF3 (END) TO SAVE CHANGES.

Command ==>
PF1=Help  PF3=End  PF12=Cancel
    
```

2. View or fill in the EDI destination address fields as described below.

Type Enter a code that indicates an EDI data type or specifies an action:

X	Indicates ANSI X12 data.
U	Indicates UCS data
T	Indicates EDIFACT, UN/TDI data.
D	Specifies you want to delete the entry
blank	Specifies the default entry for any EDI data type

Qualifier Enter a code that indicates how conversion should occur. EDI qualifiers may vary in X12 and EDIFACT data only; for UN/TDI or UCS data, specify as indicated below. For type

X12	The EDI qualifier may be up to any two characters.
EDIFACT	The EDI qualifier maybe up to any four characters
UCS	The EDI qualifier must be 01.
UN/TDI	The EDI qualifier must be left blank

Nickname Type a name that corresponds to the EDI destination in the data

3. View or fill in the Information Exchange address fields as described below. For guidance on sending specific types of data, refer also to “System option details” on page 27.

Field:	Contains:
Type	The intersystem address (I) or an alias table type: G (global), O (organizational), or P (private) , or L (list)
ID	A 3-character alias table name or intersystem identifier
Account	The Information Exchange destination account ID
User id	The Information Exchange destination user ID

The allowed combinations are described below. For detailed information, see “EDI translate table example entries” on page 35.

- a. For an account ID and user ID defined in Information Exchange alias table (see example entries 1 and 2):
 - In the **Type** field, type **G , O, or P**.
 - In the **ID** field, type the alias table name.
 - Leave the **Account** and **Userid** fields blank.
- b. For an account ID and user ID on the local system (see example entries 3 and 7):
 - In the **Account** field, type an account ID.
 - In the **Userid** field, type a user ID.
- c. For an account ID and user ID on a remote system (see example entry 6):
 - In the **Type** field, type I.
 - In the **ID** field, type the Intersystem identifier.
 - In the **Account** field, type an account ID.
 - In the **Userid** field, type a user ID.
- d. For an alias entry where the EDI destination is the alias name forwarded to Information Exchange (see example entry 5):
 - In the **Type** field, type **G , O, or P**.
 - In the **ID** field, type the alias table name.
 - Leave the **Account** and **Userid** fields blank.
- e. If the EDI destination is not to be used as the Information Exchange alias name, the Account and Userid fields can be used together as the alias name forwarded to Information Exchange (see example entries 4 and 9):

- In the **Type** field, type **G** , **O**, or **P**.
 - In the ID field, type the alias table name.
 - In the **Account** and **Userid** fields, type an Information Exchange alias name; starting in the Account field, and then continuing in the **Userid** field.
- f. For a distribution list (see example entry 8):
- In the Type field, type L.
 - In the ID field, type the alias table name or distribution list name.
 - Leave the Account and Userid fields blank.
4. To delete an entry, in the EDI data Type field, type D.
 5. To validate your entries without leaving the panel, press Enter.
 6. To save your changes, press PF3.
- Expedite/CICS saves the information and displays the Administration Services Selection Menu.
7. To discard typed data and return to the Expedite/CICS System Administration Selection menu, press PF12.

EDI translate table example

The following table shows an example of an EDI translate table. For more information about EDI processing, see Appendix B, “Sending and receiving EDI data.

EDI destination address				Information Exchange address				Resolved destination
Entry	Type	Qualifier	Nickname	Type	ID	Account	User ID	(20 bytes)
1				G	X01			GX01?????
2			FRANK	G	X01			GFRANKX01
3	X	AB	FRANK			IBM1	JONES	IBM1 JONES
4		12	SARAH	P	ABC	ANIEALIA	SNAME	PABCANIEALIASNAME
5	T			G	T01			GT01?????
6	U	01	JOHN	I	USA	ACCTX	USER01	IUSAACCTX USER01
7	TS	DUNS	012345			YOUR	PARTNER	YOUR PARTNER
8		08	EDIDEST	L		LIST01		
9	X	ZZ	PETER	O	X1X	ALIASONI	E	0X1XALIASONIE



NOTE: The Resolved destination entries are constructed as follows:

This bytes:	Contain the:
1	Alias table type or I (Intersystem); otherwise, blank
2-4	Alias table name; otherwise, blank
5-12	Account ID or the first eight characters of the alias name
13-20	User ID or the last eight characters of the alias name

EDI translate table example entries

Entry	Explanation
1	Because no data type, qualifier, or nickname is specified, this is a default entry for any EDI destination not found in the translate table. ????? is the nickname from the EDI data (destination address) that follows the alias table type (G) and alias table ID (X01) entries and is forwarded to Information Exchange for delivery to an Information Exchange alias destination. This entry assumes the EDI destination address has been defined to Information Exchange in the GX01 alias table.
2	Because no data type or qualifier is specified, any data with nickname FRANK, is forwarded to Information Exchange for delivery to the Information Exchange alias destination GX01FRANK. This entry assumes the EDI destination address has been defined to Information Exchange in the GX01 alias table.
3	A complete X12 entry; any X12 data with nickname FRANK and qualifier, AB, is sent to the Information Exchange Account/Userid GXS1 JONES
4	Because no data type was specified, any data with qualifier 12 and nickname SARAH is forwarded to Information Exchange for delivery to the Information Exchange alias destination PABCANIEALIASNAME.
5	Because a data type but no qualifier or nickname is specified, any EDIFACT or UN/TDI data is forwarded to Information Exchange for delivery to an Information Exchange alias using the nickname from the EDI destination address concatenated with GT01. This entry assumes the EDI destination address has been defined to Information Exchange in the GT01 alias table.
6	A complete UCS entry (qualifier must be 01). Any UCS data with nickname JOHN is forwarded to Information Exchange and delivered to the remote Information Exchange system USA user ACCTX USER01
7	A complete EDIFACT entry. Any EDIFACT data with qualifier DUNS, and nickname 012345 is sent to the Information Exchange Account/Userid YOUR PARTNER.

8	Sends EDI data containing qualifier 08 and nickname EDIDEST to the destinations contained in the Information Exchange distribution list named LIST01.
9	A complete X12 entry. Any X12 data with qualifier ZZ and nickname PETER is forwarded to Information Exchange for delivery to Information Exchange alias destination OX1XALIASONIE.

EDI send options



NOTE: The methods for sending EDIFACT and UN/TDI data to a distribution list changed starting with Version 4, Release 2 of Expedite/CICS.

Although the translate table works the same for all EDI standard data types, there are varying methods for deciding how or where the resolution to an Information Exchange destination can be achieved. Because the location of the destination address within an EDI envelope depends on the type of EDI data being transmitted, Expedite/CICS determines where to send the EDI data by examining the contents of the envelope. The topics under this header provide brief descriptions of how to send to particular destinations, depending on the type of data you are sending.

It is recommended you resolve addresses with a method using the Expedite/CICS translate table or using Information Exchange. For more information about:

- The EDI destination field location in each data type and how EDI processing works, refer to the Expedite/CICS Display Application User's Guide.
- Each EDI standard, contact the relevant standards board.

X12 data options

When sending to:

- An account ID and user ID:
 - Use the translate table to resolve the destination contained in the EDI data to an Information Exchange account ID and user ID.
 - Specify a real account ID and user ID in the EDI header destination field as follows:
 - Separate the account ID and user ID by a period (.), slash (/), or one or more blank spaces.
 - Use an interchange ID qualifier of ZZ.
 - Ensure no translate table entry matches these criteria.
- A distribution list:
 - Specify the nickname in the EDI destination field (the EDI type and Qualifier may be filled in).
 - Use a type of L in the Information Exchange address.
 - Enter the list name in the Account field of the Information Exchange address.

- An alias:

Use the translate table to resolve the destination contained in the EDI data to an Information Exchange alias name.

UCS data options

When sending to:

- An account ID and user ID:

- You must use the translate table to resolve the destination contained in the EDI data to an Information Exchange account ID and user ID.
- You may not specify a real account ID and user ID in the EDI header.

- A distribution list:

- Specify the nickname in the EDI destination field (the EDI type and Qualifier may be filled in).
- Use a type of L in the Information Exchange address.
- Enter the list name in the Account field of the Information Exchange address.

- An alias:

Use the translate table to resolve the destination contained in the EDI data to an Information Exchange alias name.

EDIFACT data options

When sending to:

- A system ID, account ID, and user ID:

- Use the translate table to resolve the destination contained in the EDI data to an Information Exchange system ID, account ID, and user ID.
- Specify the real system ID, account ID, and user ID in the EDI header destination field as follows:
 - Separate the system ID, account ID, and user ID with a period (.), slash (/), or one or more blank spaces.
 - If you do not use a system ID, just enter the account ID and the user ID. Do not enter a period or blank before the account ID.
 - Use an identification code qualifier of ZZ.
 - Ensure no translate table entry matches these criteria.

- A distribution list:

- Specify the nickname in the EDI destination field (the EDI type and Qualifier may be filled in).
- Use a type of L in the Information Exchange address.
- Enter the list name in the Account field of the Information Exchange address. An alias:

Use the translate table to resolve the destination contained in the EDI data to an

Information Exchange alias name.



NOTE: System ID is optional for EDIFACT

UN/TDI options

When sending to:

- A system ID, account ID, and user ID:
 - Use the translate table to resolve the destination contained in the EDI data to an Information Exchange system ID, account ID, and user ID. In this case, the EDI destination must be specified in the first subelement of the UNTO data element.
 - Specify a real system ID, account ID, and user ID in the EDI header destination field in the second subelement of the UNTO data element as follows:
 - Separate the system ID, account ID, and user ID by a period (.), slash (/), or one or more blank spaces.
 - If you do not use a system ID, just enter the account ID and the user ID. Do not enter a period or blank before the account ID.
 - Ensure the first subelement of the UNTO data element does not exist.
- A distribution list:
 - Specify the nickname in the EDI destination field (the EDI type and Qualifier may be filled in).
 - Use a type of L in the Information Exchange address.
 - Enter the list name in the Account field of the Information Exchange address



NOTE: System ID is optional for UN/TDI

- An alias:

Use the translate table to resolve the destination contained in the EDI data to an Information Exchange alias name.

Customizing Expedite/CICS transaction names

Expedite/CICS provides a default Transaction ID (TRANSID) to manage various functions you perform, such as sending a file, restarting a session, or logging off.

You can use the SYSTEM/DEFAULT ID (if you are a service administrator, your own user ID) to change the name Expedite/CICS assigns to a transaction; for example, if you already use the default name for another transaction. If you are a general user, you can view the list of transaction IDs.



CAUTION: You should change transaction names during Expedite/CICS installation, as needed. If transactions are renamed using the procedure below, a program control table (PCT) definition must be changed also in order for the transaction to start the appropriate Expedite/CICS program. Conversely, if you change the PCT, the corresponding transaction IDs on the Define Expedite/CICS Transactions panel must be changed also. These tasks are usually performed by a system programmer. If you change the transaction name of the listener (LSTN), you must also change the TRANS ID parameter in the TCP/IP configuration macro (EZACICD).

To work with transaction names, begin on the Expedite/CICS System Administration Selection menu.

1. Select option 3, Set/view transaction names Expedite/CICS displays the Define Expedite/ CICS Transactions panel with your account ID, user ID, and transaction IDs (default and current) already filled in. The values in the Current TRANSID column indicate the trans-action IDs actually in use on your CICS system.

```

EXPMD6          Define Expedite/CICS Transactions

Account         ACCT
Userid          USER01

Transaction Description      Default TRANSID      Current TRANSID

Display Application..... < LG01 >          < LG01 >
Reset User Session..... < IDLT >          < IDLT >
LU 6.2 Receive data..... < ISC2 >          < ISC2 >
Process Receive 1..... < IMR1 >          < IMR1 >
Process Receive 2..... < IRM2 >          < IRM2 >
Send Data Task..... < IST1 >          < IST1 >
Manage User Logoff..... < ISB2 >          < ISB2 >
Activity Monitor..... < EXPR >          < EXPR >
Batch Monitor..... < EXPS >          < EXPS >
Listener..... < LSTN >          < LSTN >
Child Task..... < TCHD >          < TCHD >

HI313 ENTER TRANSACTION IDS AND PRESS PF3(END) TO SAVE CHANGES.

Command ==>
PF1=Help  PF3=End  PF12=Cancel

```

2. Type values in the Current TRANSID fields, as needed, according to the information provided in Table 4.

Table 4. Transaction ID parameters

Transaction/Default:	Transaction Description:
Display Application (LGO1)	Invokes the Expedite/CICS Display Application and subsequent panel processing. LGO1 is invoked by the user from a cleared native CICS screen
Reset User Session (IDLT)	Resets a user's session (a session start must then be issued to enable the user to continue). IDLT can be invoked either from native CICS or through the List user session status option of the User Session Selection Menu. See “Reset a user session” on page 290
LU 6.2 Receive Data	Invoked when data is sent in an LU 6.2 session from Information Exchange to Expedite/CICS, ISC2 receives data from the session and invokes the Process Receive 1 transaction to start the Expedite/CICS receive process for incoming data.
	
	<p>NOTE:</p> <ol style="list-style-type: none"> 1. The transaction must be coded in the terminal control table (TCT) TYPE=MODESET definition for sessions in the TRANSID parameter. With CICS/ESA systems, this parameter is no longer used 2. Because Information Exchange is a remote facility that invokes ISC2 when receiving data, transaction ISC2 must be defined to your external security package and the TRANSEC value for the PCT definition must have a value that allows remote facilities to access it.
	Transaction name ISC2 is hard-coded in both Expedite/CICS and Information Exchange. To change this name, you must code a terminal-attach exit to redefine the transaction to be executed. Refer to CICS manuals for detailed procedures.

Table 4. Transaction ID parameters

Transaction/Default:	Transaction Description:
Process Receive 1 (IMR1)	<p>When Information Exchange sends data to Expedite/CICS across the LU 6.2 session, transaction ISC2 is started to read the data from the session, then transaction IMR1 is started to run Expedite/CICS receive programs which:</p> <ul style="list-style-type: none"> ■ Receive data to the receive data (EXPRDAT) file; notify Information Exchange the data was received. ■ Write data to a user destination or pass it to a user receive program. ■ Link (optional) to user exit programs. ■ Clean up and delete data when a receive completes successfully.
Process Receive 2 (IRM2)	This transaction is reserved for future use.
Send Data Task (IST1)	<p>Data being sent to Information Exchange can be sent synchronously or asynchronously, as specified in a user's profile. Synchronous data is sent under the initiating user transaction (or LGO 1 if issuing from the Display Application). Control is not returned to the user until the send process is successfully completed and the entire message is sent to Information Exchange.</p> <p>Asynchronous processing returns control to the user as soon as the data to be sent is successfully loaded into the send data file EXPSDAT. Then the send data task (IST1) is started to read the data from EXPSDAT and forward it to Information Exchange to complete the send process.</p>
Manage User Logoff	This transaction is used to manage and complete a request to end a user's Information Exchange session.

Table 4. Transaction ID parameters

Transaction/Default:	Transaction Description:
<p>Activity Monitor (EXPR)</p>	<p>This CICS task runs periodically (default = 30 minutes) to:</p> <ul style="list-style-type: none"> ■ Monitor connections and sessions and restart, as needed, to: <ul style="list-style-type: none"> • Verify that Information Exchange links are in service. • Inquire about active users; reset if session problems are detected (indicated by an SDIERR from Information Exchange). • Check active single and continuous receive requests; reset users, and thus receive requests, which are not processing correctly. ■ Delete expired control records associated with successfully completed send and receive requests. Expiration is controlled by the values set in the Send file retention and Receive retention fields of a user profile. After the number of days specified in the Not-Sent Not-Received Retention parameter on the Define System Options panel, the activity monitor purges control and data records associated with requests with status: E-HIxxx, COMPLETE, and HELD. To avoid peak processing times, Expedite/CICS does not purge records between the time specified on the Define System Options panel. <p>The activity monitor rest interval is set on the Define System Options panel as described in. For more information, see Appendix A, “Understanding automated restart and recovery.”</p>
<p>Batch Monitor (EXPS)</p>	<p>Monitors for batch send activities and sends batch data to Information Exchange. The run interval default is 0000 seconds. This value should be set to 0015 if batch send is going to be used.</p>
<p>Listener (LSTN)</p>	<p>This transaction starts at CICS startup when Communication method in the override file is set to TCP. It listens for connection requests from the port number specified in UserPortNumber in the override file. The Listener accepts connection requests and starts a child task (TCHD) to continue communication, and then returns to Listen mode. This transaction is used during the receive process when Information Exchange attempts to connect to Expedite/CICS at the IP address and port specified in the override file.</p>
<p>Child Task (TCHD)</p>	<p>This transaction is started by the Listener transaction after a connection is accepted. It verifies the identity of Information Exchange before beginning the receive process.</p>



NOTE: The batch send monitor and the activity monitor are initially set to run

when Expedite/CICS initializes during system startup. During Expedite/CICS initialization, Information Exchange connections are checked and active user sessions are restarted. If, when the activity monitor runs, it detects a problem with the Information Exchange connection, the initialization procedure is invoked again.

3. When you finish typing your transaction ID changes, do one of the following:
 - Discard typed values, return to the Expedite/CICS System Administration Selection menu, and press PF12.
 - Save typed values, return to the Expedite/CICS System Administration Selection menu, and press PF3.

Customizing trace options

Expedite/CICS provides an internal command trace that can be useful in developing and supporting Expedite/CICS applications. For example, you can use this trace facility when testing Expedite/CICS after installation or when troubleshooting problems to view all data elements sent to and received from Information Exchange.

Before you use the trace function for troubleshooting, you may want to use the PURGE option on the Trace Options panel to purge the existing trace data. This will make your test commands and data easier to find.

The internal command trace is very helpful to Expedite/CICS support personnel, who may ask you to forward a copy of the trace file.

You can use the SYSTEM/DEFAULT ID, if you are a service administrator, your own user ID, to start and stop the trace for various elements. If you are a general user, you can view the options to determine if a trace is active for an element.

On the Trace Options panel, you indicate which elements you want to trace. The trace flags tell Expedite/CICS what kind of data you want written to the Expedite/CICS internal trace temporary storage queues, EXPDTRCA and EXPDTRCB. The first 125 bytes of this data is also written to the Log TDQ, EXPL, if the Log Trace flag is set to Y. To set up the trace options, begin on the Expedite/CICS System Administration Selection menu.

1. Select option 4, Start or stop trace facility.

Expedite/CICS displays the Trace Options panel.

```

EXPMTRI                      Trace Options

Enter Y (yes) or N (no) in the fields

Purge
  Purge trace.. < N >

Trace
  Commands..... < Y >
  Send..... < Y >
  Receive..... < Y >
  Data..... < N >

TCP/IP Trace Options
  Start up Farms..... < N >
  TCP/IP Send..... < N >
  TCP/IP Receive..... < N >

Switch trace table at record.... < 20000 > (00100 - 32760)
                                         (00000 - no switching)

Write Trace to Log EXPLOG1

  Log Trace.... < Y > (Activate trace for EXPL destination)

HI305 ENTER FIELD INFORMATION AND PRESS PF3 (END) TO SAVE CHANGES.

Command ==>
PF1=Help  PF3=End  PF12=Cancel

```

2. In each of the Trace fields, type Y or N to indicate whether or not you want to run the trace. The pertinent considerations are provided under the heading, “Trace option field descriptions” on page 44.
3. In the Switch trace table at record field, type the number at which you want the trace to switch from one trace to the other (EXPDTRCA to EXPDTRCB or EXPDTRCB to EXPDTRCA). Records in a given trace are not deleted until Expedite/CICS switches back to the trace after having previously switched to the alternate trace.

Valid values range from 100 to 32,760 (maximum size of a TSQ is 32,767) records. The default is 20,000 records, which means a maximum of 40,000 records can exist at one time. Zeros indicate no switching will be done. In this case, you need to monitor the record count to ensure it is less than 32,760.

4. In the Log Trace field, type Y or N.

If this flag is set to Y, the first 125 bytes of data written to the internal trace TSQs is also written to log TDQ, EXPL. For more information about how this TDQ is defined and used, see “Log TDQ (EXPL)” on page 329.

5. When you have finished filling in field values, do one of the following:
 - Save typed values in the user profile, return to the Expedite/CICS System Administration Selection menu, and press PF3.
 - Discard typed values, return to the Expedite/CICS System Administration Selection menu, and press PF12.

Trace option field descriptions

The descriptions below are provided to help you fill in the trace option fields as needed. For more information about trace destinations and trace output, see “Using Expedite/CICS problem determination facilities” on page 313.

Purge trace

When this option is set to Y, the internal trace queues (EXPDTRCA and EXPDTRCB) are purged. The Log trace (EXPL) is not purged.

Trace Commands

When this option is set to Y, most commands, excluding those that contain data, will be written to the trace. This includes the following:

- Commands to the command processor and the response COMMAREA.
- Information Exchange commands and responses such as Session Start, Session End, Session Inquiry, and receive requests, including the receive commit response.
- List Define, List Verify, Audit Retrieve, Probe, all library commands and all pass-through commands.



NOTE: Expedite/CICS command and response formats are provided in Chapter 6. Information Exchange command and response formats are provided in the *Information Exchange Interface Programming Guide*.

Trace Send

When this option is set to **Y**, Expedite/CICS writes commands to the trace associated with send requests, including the Expedite/CICS send file command, and the commit request and response from Information Exchange.

If the **Trace Data** option is set to **N**, only the first 300 bytes of each send message command will be written to the trace; this is sufficient to hold the command and responses.

If the **Trace Data** option is set to **Y**, all the data is written as well. In most cases, this is not necessary for problem determination.

Trace Receive

When this option is set to **Y**, Expedite/CICS writes commands to the trace associated with the receive data, including the received message header containing the data as it arrives from Information Exchange and the commit request from Information Exchange.

If the **Trace Data** option is set to **N**, only the first 300 bytes of the received message header containing the data will be written to the trace; this is sufficient to hold the command and responses.

If the **Trace Data** option is set to **Y**, the message data is written as well. In most cases, this is not necessary for problem determination.

Trace Data

When this option is set to **Y**, all commands and data sent and received are written to the trace.

The size of each record written to the trace depends on the value set in the Data transmission size field on the Define System Options panel. The maximum transmission size is 26,000 bytes, which includes data and command headers.

The maximum length of a trace record, which includes the task number, date, and time, is 26,027 bytes.

When this option is set to **N**, only the first 300 bytes of the command and data sent or received are written to the trace. 300 bytes is sufficient to include the commands and responses necessary for problem determination.

It is recommended that data be traced only when there is a particular question about the data being sent or received.

Switch trace table at record?

Specifies the number of records at which you want the trace to switch from one table to the other (EXPDTRCA to EXPDTRCB or EXPDTRCB to EXPDTRCA). Expedite/CICS writes to the first table until the number of records specified is reached, and then switches to the second table. When the second table contains that same number of records, Expedite/CICS deletes the data in the first table and starts writing to the first table again.

Valid values range from 100 to 32,760 (maximum size of a TSQ is 32,767) records. The default is 20,000 records, which means a maximum of 40,000 records can exist at one time. Zeros indicate no switching will be done. In this case, you need to monitor the record count to ensure it is less than 32,760.

Log Trace

When this option is set to Y, the first 125 bytes of whatever is written to the internal trace. TSQs are also written to the log TDQ, EXPL. For more information about how this TDQ is defined and used, refer to “Log TDQ (EXPL)” on page 250.

TCP/IP Start up Parm

When this option is set to Y, Expedite/CICS writes detailed information to the trace queue on the processing of each TCP/IP override parameter. If an error occurs when validating any override parameter for which there is no default value, Expedite/CICS will not process the remaining parameters and will assume SNA communication is being used. There are no default values for the Information Exchange IP address, Information Exchange port number, user IP address, user port number, and TCPNAME. The default values for the remaining parameters are as follows:

TCP/IP override parameter:	Default values:
Communication Method	SNA
Maximum Sockets	50
Activity Timeout	30 minutes
Receive Timeout Concurrent	10 minutes
Send Sessions Concurrent	1
Receive Sessions	1

This option is useful when you need to find out which parameter is causing Expedite/CICS to assume SNA communication when you have specified TCP/IP communication.

TCP/IP Send

When this option is set to Y, all send-related TCP/IP commands sent to, and responses received from, the TCP Relay are written to the trace. Along with the message indicating which command is being sent or received, the complete command is written to the trace log. Although this is useful when trying to identify a problem relating to communication with Information Exchange, setting this option to Y will fill up the Expedite/CICS trace queues more quickly. We recommend that you set this option to N unless there is a specific problem you are trying to trace. These commands include:

TCP/IP command:	Purpose:
TCP-HOST-ASSIGN	Expedite /CICS uses this command to request the address of the next available server. This allows Information Exchange to balance the load on the system and provide better performance and availability.
TCP-HOST-ASSIGNED	This is Information Exchange’s response to the TCP-HOST- ASSIGN command. Expedite/CICS uses the address and port number returned in this response to reconnect to Information Exchange.
TCP-START	Expedite/CICS uses this command to establish a conversation with Information Exchange’s TCP Relay.

TCP/IP command:	Purpose:
TCP-STARTED	This is Information Exchange's response to the TCP-HOST-START command which indicates that the TCP Relay is ready to start communication.
TCP-SEND	Expedite/CICS uses this command to communicate to the TCP Relay that there is data to be sent to Information Exchange.
TCP-RECEIVED	Information Exchange uses this command to communicate to Expedite/CICS that there is data being sent from Information Exchange.
TCP-END	Expedite/CICS uses this command to indicate the end of the communication between Expedite/CICS and the TCP Relay.
TCP-ENDED	This is Information Exchange's response to the TCP-END command which indicates the end of communication between TCP Relay and Expedite/CICS.

TCP/IP Receive

When this option is set to Y, all receive-related TCP/IP commands received from the TCP Relay, and responses sent to the TCP Relay, are written to the trace log. Along with the message indicating which command is being sent or received, the complete command is written to the trace log. Although, this is useful when trying to identify a problem relating to communication with Information Exchange, setting this option to Y will fill up the Expedite/CICS trace queues more quickly. We recommend that you set this option to N unless there is a specific problem you are trying to trace. These commands include:

TCP/IP command:	Purpose:
TCP-IDENTIFY	This command is sent by the TCP Relay to Expedite/CICS when Information Exchange has data to send to Expedite/CICS in response to a receive command (SDIRCVN) sent to Information Exchange. This command is the first step in the identify validation process.
TCP-IDENTIFIED	Expedite/CICS sends this command to the TCP/IP Relay after confirming the identify of the TCP Relay. Data is only received after the TCP Relay has been successfully identified.
TCP-RECEIVED	This command is used to communicate to Expedite/CICS that data is being sent from Information Exchange.

Error messages and informational messages are written to the internal trace TSQs when one or more of the trace flags is set to Y. If all flags are set to N, nothing at all is written to the TSQ. When any flag is set to Y, the writing of error messages and informational messages becomes active.

Customizing Information Exchange options

Each Expedite/CICS user, identified by an Account/Userid and password, must have a matching Account/Userid and password on Information Exchange to enable that user to communicate between Expedite/CICS and Information Exchange. Information Exchange user profiles are usually defined by an Information Exchange system administrator using Information Exchange Administration Services. Other Information Exchange parameters that should be considered when customizing Expedite/CICS are listed below.

Parameter	Description
Charges	<p>Charges Charge options (who will pay for sending and receiving) are defined in Information Exchange user profiles. Exception overrides can be defined in the Information Exchange trading partner list. Information Exchange profile options work in conjunction with Send MSGCHRG values.</p> <p>Details of billing should be received from your local representative as they differ internationally, and can change from time to time.</p> <p>In the United States, customers can select GETINFO from the AT&T Global Network Services Service Selection Menu for charge information.</p>
Archive	<p>The archiving feature identifies the number of days that received messages are archived in Information Exchange. Messages are archived if the value in the user Information Exchange profile Forced archiving field is Y.</p> <p>Messages are archived in groups named by the session access key. Therefore, each message you send during a session is archived in one group. The archive reference ID can be changed by identifying a specific name in the ARCREFID of the Receive Message command.</p> <p>Archive groups can be retrieved using the Archive Retrieve command. Single messages can be retrieved using Information Exchange Administration Services. Retrieved messages are put into the mailbox from which they were received. Information Exchange archive is a form of Expedite/CICS message backup. In addition, the Expedite/CICS user information exit can be customized to provide an audit of data sent and received asynchronously by Expedite/CICS.</p>
Audits	<p>Audit trails provide a history record of messages SENT to and RECEIVED from a user's mailbox. The audit information can be viewed using Information Exchange Administration Services, or it can be retrieved into your Information Exchange mailbox and received to your Expedite/CICS system. Expedite/CICS provides a sample program that formats the audit information into a report. For more information about the program, see Appendix B, "Sample Programs." For a sample of the audit report, see the <i>Information Exchange Administration Services User's Guide</i>.</p>

Parameter	Description
Alias tables	<p>An alias table is a list of alternate names that a user can use to send a message to other users. These alternate names are easier to remember than users' Information Exchange accounts and user IDs. The table is created by the Information Exchange administrator using the Information Exchange Administration Services application.</p> <p>For sending EDI data, you may choose to maintain these alias names with Expedite/CICS instead of Information Exchange. This is done by using the Expedite/CICS EDI Translate Table, which can convert an EDI destination contained in the EDI data into either an Information Exchange Account/Userid or point to an Information Exchange alias table for the final address resolution.</p>
Distribution lists	<p>A list of users to whom a user sends the same mail. For example, if a user regularly sends the same business document to users in various business offices of a company, the user can send the mail to all those users at one time by creating a distribution list. When the user sends the document to the distribution list, Information Exchange delivers the document to all the users' mailboxes in the list.</p> <p>Permanent distribution lists are created in Information Exchange using Information Exchange Administration Services. Temporary distribution lists are created in Expedite/CICS and uploaded to Information Exchange, and are used for the duration of a session.</p>
Mailboxes	<p>To enhance individual productivity, multiple Account/Userids can be established, each performing specific tasks according to user requirements</p>
Reset a user's password and session	<p>Can be performed using Information Exchange Administration Services</p>

Many other features are also provided through Information Exchange Administration Services and are described in the *Information Exchange Administration Services User's Guide*.

Customizing Display Application menus

Expedite/CICS Display Application menus can be customized for your account to add or remove local application features. Adding applications, however, requires some application coding changes to ensure the Expedite/CICS selection program gets control back and knows where to pass control on subsequent calls. In addition, maintenance requirements increase when new versions of Expedite/CICS are delivered. Because the above is true, customizing Display Application menus is not recommended.

Expedite/CICS provides program EXPBMENU, to use in customizing Display Application menus and a sample job stream containing the default menus. EXPBMENU checks the format of any customization data you enter, and places the data into the Send/Receive/Control file (EXPDSRC). If you do not intend to customize the menus, you can run this job as-is.

The JCL library furnished on the Expedite/CICS tape contains the sample job stream for executing program EXPBMENU. The job stream also describes the procedure for customizing the menus. Comments are placed in the job stream to help you make the necessary JCL changes to install Expedite/CICS. If you customize the Display Application menus, be sure to follow these rules.

- The keywords must be in the following order:
 MENUNAME, MENUTITLE, OPTNUM, OPTNAME, OPTDESC, OPTPGM,
- Each keyword must end with a comma.
- Keyword fields cannot be continued to the next statement and cannot extend beyond Column 72.
- All menu names must begin with MENU; for example, the Receive menu name is MENSURECV.
- The first menu name in the job stream must be MENUMAIN.
 MENUNAME=MENUMAIN, MENUTITLE=MAIN MENU SELECTION,
- Each menu must have a MENUNAME, a MENUTITLE, and at least one option.
- Each option must have one and only one of each keyword; for example:

```
OPTNUM=N, OPTNAME=CCCCCCCCCCC,
OPTDESC=DDDDDDDDDDDDDDDDDDDDDDDDDDDDDDDDDDDDDDDDDDDDDDDDDDDDDDDDDDDD
DD, OPTPGM=PPPPPPPP,
```

This keyword:	Is the:
OPTNUM	One-character option number (must be a numeric character 0 - 9 or an alphabetic character A - Z).
OPTNAME	Option command (1 - 11 characters)
OPTDESC	Description of the option that appears on the menu (1 - 37 characters)
OPTPGM	Name of the program to which control is given when the option is selected.

An example of the code for the first option on the Display Application Receive menu follows:

```
MENUNAME=MENSURECV, MENUTITLE=RECEIVE SELECTION MENU,
OPTNUM=1, OPTNAME=SINGLe,
OPTDESC=Issue single receive, OPTPGM=EXPOSIN1,
```

Display Application menu processing

The Expedite/CICS menu specifications are processed by program EXPOSEL1, which passes control (performs an XCTL) to the program you specify for that option.

Programs are passed the COMMAREA EXPCASP, with the account, user ID, and previous program fields filled in.

Upon return, programs pass control to the program identified in SPLASPGM (last program), move spaces to SPNXTPGM (next program), and return the COMMAREA. For example:

```
MOVE SPLASPGM TO WS-NEXTPGM.  
MOVE SPACES TO SPNXTPGM.  
EXEC CICS XCTL PROGRAM(WS-NEXTPGM) COMMAREA(WS-COMMAREA)  
LENGTH(COMLNG) ENDEXEC.
```

For more information, refer to copybook EXPCASP in the distribution library defined for your installation. Additional information can be obtained from the *Expedite/CICS Program Directory* or your application programmer.

Reorganizing system files

It is highly recommended that your installation use a procedure to periodically reorganize heavily used Expedite/CICS VSAM files. Reorganization will redistribute unused space resulting from the deletion of records, improve performance by minimizing CA and CI splits, reduce storage requirements, and prevent out-of-space conditions.

Files that need to be reorganized periodically based upon your installation volumes include:

EXPDSRC, EXPRDAT, EXPDAT, EXPDPTF, and EXPDKEY (if you are using TCP/IP).



NOTE: The EXPDERR file is a low-use file, used mainly for control records since Expedite/CICS Version 4 Release 1, and does not require regular maintenance.

Sample reorganization jobs are provided. See the *Expedite/CICS Program Directory* for more information.

Developing an Expedite/CICS application

The Expedite/CICS Display Application enables you to send and receive data through Information Exchange as soon as Expedite/CICS is installed on your system. However, your installation may require the send and receive requests to be initiated from a user program instead of a terminal. Or, you may have a requirement to process the data immediately after it has been received from the Information Exchange mailbox. You can satisfy this requirement by writing your own application programs to interface with Expedite/CICS.

This chapter discusses questions that may arise during the development process, and provides guidelines to help you choose the correct commands and options to satisfy your application requirements. The information describes how to issue commands to the Expedite/CICS command processor and check responses returned from Expedite/CICS.

The major topics in this chapter are listed below:

Planning application development	60
Understanding the Expedite/CICS command processor	66
Identifying what user programs must be developed	76
Designing an application	79
Using the TCP/IP function of Expedite/CICS	88
Sending data to Information Exchange	92
Receiving data from Information Exchange	109

Planning application development

Before you write an application program, review your data collection process by following the general steps listed below:

1. Describe your current process.
2. Define new application requirements.
3. Choose appropriate Expedite/CICS parameters to satisfy the requirements.

To help you do this, the following checklists are provided:

- “Checklist for describing your existing process” below
- “Checklist for defining new application requirements” on page 55
- “Checklist for matching Expedite/CICS features with application requirements” on page 57

Checklist for describing your current process

How many trading partners do you have?

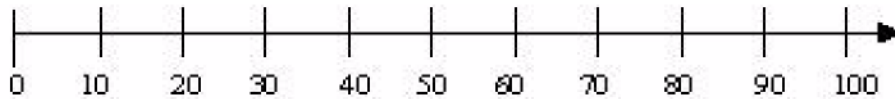

- Are you:
 - sending data
 - receiving data?
- Who pays for data exchange?
 - Sender
 - Receiver
 - Split



NOTE: Charges are defined to Information Exchange in the Information Exchange user profile or trading partner list.

- What is the format of the data you will send and receive?

Request	X12	UCS	EDIFACT	UN/TDI	LL	PC	OTHER
Send							
Receive							

- What is the average message size you send and receive?

Request	< 250 Bytes	250 Bytes-1KB	> 1 KB	> 1 MB
Send				
Receive				

- How many messages do you and your trading partners exchange during periods of peak activity?

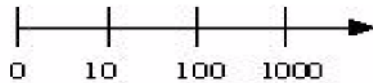

- What file format is send data sent from and receive data received into?



NOTE: You need to determine how data will be placed in a file type that is supported by Expedite/CICS

Send	Receive
<ul style="list-style-type: none"> • Sequential data set • CICS temporary storage queue (TSQ) • CICS transient data queue (TDQ) • Virtual storage access method (VSAM) • Entry-sequenced data set (ESDS) • Key-sequenced data set (KSDS) • Relative sequential data set (RSDS) • Data base, such as DB2 • Other 	<ul style="list-style-type: none"> • Sequential data set • CICS TSQ • CICS TDQ • VSAM • ESDS • KSDS • RSDS • Data base • Other

- How often are the send and receive processes performed?
 - Daily
 - Weekly
 - Other
- What translator do you use to send and receive in a Standard EDI format?
 - Data Interchange CICS
 - Other
- What file format is required by the translator?
 - Sequential file
 - Temporary storage queue (TSQ)
 - Transient data queue (TDQ)
 - Other
- What record format is required by the translator?
 - Fixed
 - Variable

- Is exception reporting in place for send and receive?
 - Yes
 - No
- What restart and recovery backup procedures are used?

Checklist for defining new application requirements

Send processing

- How and when will the application that issues the Send File command be invoked?
 - At a specific time interval (CICS interval control)
 - Batch (batch send only)
- When sending data, will you need an additional process to write the data into one of the Expedite/CICS supported file formats, VSAM ESDS, TSQ or extrapartition TDQ?
 - Yes
 - No
- What type of acknowledgment do you require from trading partners when they receive messages you have sent to their mailbox?
 - Information Exchange acknowledgments - SM-CRCPT field in a Send File command
 - End-to-end acknowledgments; for example, EDI functional acknowledgments
- Will you be sending compressed data? See Appendix C, “Using data compression,” for more information on data compression.

Receive processing

For more information about Receive Message command fields, see “Receive Message command” on page 237.

- How and when will the program that issues the receive message command be invoked?
 - At a specific time interval
 - After a specific time event
 - Batch
- When receiving data, will you need an additional process to write the data into a file format required for the receive application such as a translator?
 - Yes
 - No
- When you receive messages from your trading partner, are you expected to reply within a specified time interval? If Yes, consider using continuous receive.
 - Yes
 - No

If Yes, specify: ____ minutes ____ hours.

- Do you need to receive data from your trading partner as soon as it is placed in your mailbox?

- Yes
- No

If Yes, consider using continuous receives. For more information, see “Requesting a single or continuous Receive” on page 99.

- Is a batch job external to CICS required to process received data?

- Yes
- No

If Yes, see “Invoking a receive program external to CICS” on page 113 and Chapter 5, “Processing batch data using Expedite/CICS.”

- Will you be receiving compressed data?

See Appendix C, “Using data compression,” for more information on data compression.

Error recovery and backup

- What error notification and backup recovery procedures will you use?
 - Send and receive completion notification (see “Expedite/CICS completion-notification acknowledgments” on page 122)
 - Exception message processing (see “Using Expedite/CICS problem determination facilities” on page 313)
 - Receive message backup, using Information Exchange archive facilities
 - Send message backup

Checklist for matching Expedite/CICS features with application requirements

- How will you invoke Information Exchange send and receive requests?
 - Display Application
 - CICS application
 - Batch job (send only)

If you will use a CICS application, continue with the checklist. If you need more information about invoking commands using the:

- Batch facility, see Chapter 5, “Processing batch data using Expedite/CICS”
- Display Application, refer to Using the Expedite/CICS Display Application

Send options

- What options will be specified on the Send File (EXPSNDF) command?
 - SF-FNAM - File name

- SF-FTYPE - File type: TS, TD, or VS
- SF-DTYPE - Data type: E(EDI), A(CRLF), B(LL), or O(Other)
- An Information Exchange address, alias name, or list:
 - SF-CDACCT - Receiver's account ID
 - SF-CDUSER - Receiver's user ID
 - SF-CDTYPE - Indicates a list or Information Exchange address
 - SF-CLTYP - Alias table type
 - SF-CLID - Alias table ID



NOTE:

1. When sending EDI data (SF-DTYPE=E), these fields are not coded because the receiver's address is in the EDI header.
2. When sending to an alias, the SF-CDACCT and SF-CDUSER fields are used for the alias name.

- SF-CUMSGC - User message class
- SF-CRCPT - Acknowledgments

For more information, see “Sending data to Information Exchange” on page 82 and “Send File command COMMAREA format” on page 257.

Receive options

- What options will be specified on the Receive Message SDIRCVM command?

For background information, see “Receiving data from Information Exchange” on page 98 and “Receive Message command COMMAREA format” on page 237.

- RM-FNM - File or program name of the data destination
- RM-FTYPE - File type - TS, TD, VS, or PG (see “Considering the receive destination” on page 107)
- Record Handling parameters:
 - RM-DTYPE - Data type: E(EDI), A(CRLF), B(LL), or O(Other)
 - RM-CNTL - Retain Information Exchange header information with data
 - RM-WRAP - Incoming data format
 - RM-LENG - Maximum record length for a received file or message

For background information, see “Receiving data from Information Exchange” on page 98 and “Receive Message command COMMAREA format” on page 237.

For information about RM-DTYPE, RM-CNTL, RM-WRAP, and RM-LENG, see “Receive Message command COMMAREA format” on page 237.

- RM-TYPECMND; type of receive (see “Requesting a single or continuous Receive” on page 99.)
- RM-DESTACCT and RM-DESTUID; receive from a specific user or alias
- RM-MSGUCLS; receive messages sent with a specific user class
- RM-RTYPE; receive messages flagged as EDI or non-EDI data



NOTE: For information about RM-MSGUCLS and RMRTYPE see “Receiving messages from multiple trading partners” on page 107.

- Is the data you receive from your mailbox for

- one or
- multiple applications?

See “Issuing multiple receives” on page 107.

■ Do trading partners send to

- one mailbox
- multiple mailboxes?

See “Issuing multiple receives” on page 107.

■ How will you process data you receive?

- CICS application (see “Invoking a receive program internal to CICS” on page 109.)
- Batch job (See “Invoking a receive program external to CICS” on page 113 and Chapter 5, “Processing batch data using Expedite/CICS.”)

Understanding the Expedite/CICS command processor

The Expedite/CICS command processor performs the tasks listed below.

- Accept and process commands passed from either of the following:
 - The Expedite/CICS Display Application
 - A user-written program
- Return responses to the calling program to indicate the command was processed.
- Direct communication between the CICS system and Information Exchange.
- Provide automatic error recovery, as explained in Appendix A, “Understanding automated restart and recovery.”

Because the Display Application handles the user-to-command processor interface, the procedure that follows discusses only interaction between the Expedite/CICS command processor and a user program. To invoke the command processor for any type of command request, proceed as described below.

Invoking the command processor

Your application must pass all commands and data it sends to and receives from Information Exchange through the Expedite/CICS command processor, EXPOICMD. The interface between your program and the command processor is a 500-byte communication area (COMMAREA).

1. Copy the command COMMAREA into the working storage area of your program. The COMMAREA format for each command you can issue is provided in Chapter 6, “Using Expedite/CICS commands in your application,” and on the product installation tape. The copybooks are named according to command name.
2. Move the appropriate values into the fields of the COMMAREA command format. For example:
 - If the COMMAREA contains a Send File (EXPSNDF) command, you must provide Expedite/CICS with the following:
 - The name of the file you want to send
 - The file type
 - The Information Exchange address for the file recipient
 - If you are using the Send File command, you can use the Verify before sending parameter (SF-C VFYL) to ask Expedite/CICS to validate the Information Exchange recipient address before the file is sent.
 - You can request Information Exchange acknowledgments as explained in “Understanding acknowledgments” on page 117.
 - If the COMMAREA contains a Receive Message (SDIRCVM) command, specify the following for the data being received:
 - Destination file name; if your application requires event driven processing, you may optionally specify a program name as the destination for the data instead of a file name.
 - Receive type (single or continuous)
 - Data format
 - File management type: PG, TS, TD, or VS

- If you are using the File command, you can request the Compress parameter (SF-COMPRESS) to perform data compression. The compression/decompression product from Comm-Press, Inc. is required to use this function. An error message will be returned to your program if the compression product is not installed and you set this parameter to Y or T. See Appendix C, “Using data compression,” for more information.

3. Invoke the command processor by issuing the following command:

```
EXEC CICS LINK PROGRAM(EXPOICMD) COMMAREA(XXXXXXXX) LENGTH(500) END-EXEC
```

XXXXXXXX is the name of the COMMAREA in the working storage section of your program.

The Command Processor reads the COMMAREA passed to it by your program and validates the command before returning a response to the user program that issued the EXEC CICS LINK command.

Expedite/CICS returns the response to the user program in a COMMAREA, the layout of which is described in copybook EXPCRSP. This copybook is explained later in this chapter and a soft copy is also provided on the install tape. Your program must copy this COMMAREA format into the user program and interpret the response returned from Expedite/CICS.

For example, Table 5 shows the fields you must pass to the command processor in the SDISSTA COMMAREA to issue a Session Start command.

Issuing a Session Start

Your application can start a session with Information Exchange by issuing the Session Start command, SDISSTA. You do not need to issue this command in your program if the Autologon flag in your Expedite/CICS user profile is set to Y, because Expedite/CICS will start the session at CICS startup. It is recommended, however, that you include the COMMAREA in your program so that, if you receive a response from any command stating the session is not started, you can issue the session start from your program.



NOTE: Response-oriented Information Exchange commands generate immediate responses. For example, when Expedite/CICS sends a Session Start command to Information Exchange, Information Exchange immediately returns a Session Start response. Expedite/CICS returns a copy of the response to your application in the EXPCRSP COMMAREA when control is returned to your application. Your application is responsible for checking the response to locate and correct errors. For more information about interpreting responses, see “Command processor responses” on page 63.

Table 5 describes the Session Start command.

Table 5. Session Start command COMMAREA parameters

Column	Size	Name	Description	Value
1	1	S SPAS S	Pass-through indicator	0 (zero)
2	8	SSQNAM	Temporary storage queue name	blank
10	2	SSPAD	Filler	blank
12	1	SSDTYPE	Data Type	blank

Table 5. Session Start command COMMAREA parameters

Column	Size	Name	Description	Value
13	8	SSFILR	Filler	blank
21	8	SSNAME	Command name	SDISSTA
29	8	SSACCT	Account ID	Account name
37	8	SSUSER	User ID	User ID name
45	8	SSPWD	User password	Password
53	8	SSNPWD	New password of user	Optional
61	8	SSRSP	Response name	blank
69	8	SSTYP	System type	blank
77	4	SSLVL	System level	blank
81	1	SSRECOV	Send processing mode	C, M, A, or S
82	5	SSMXMSG	Maximum message size	blank
87	5	SSMXMSGP	Maximum message between Commit requests	blank
92	8	SSPCMD	Commit command name	blank
100	8	SSREST	Reset indicator	blank
108	5	SSSCHKP	Send checkpoint indicator	blank
113	5	SSRCHKP	Receive checkpoint indicator	blank
118	5	SSTZONE	Time zone	>blank<
123	1	SSEXP	Expansion indicator	blank

Each COMMAREA layout diagram contains the same information:

Column	Indicates the column in which a field begins
Size	Indicates the number of characters each field contains
Name	Indicates the name of the field
Value	Indicates the field value required by the command

In Table 5 on page 60, Value entries may be interpreted as follows:

This value	Indicates
>blank<	Expedite/CICS supplies the field value; your application can use the default or override it.
blank	A value is either not required or is supplied by Expedite/CICS; your application cannot override it.

When allowed, your application can use Expedite/CICS default values or override them as follows:

- To temporarily override default values, pass the override values to Expedite/CICS in the command COMMAREA each time you send the command. These values are valid for the rest of the session or until you send the command again using different values.
- To permanently change the session default values, refer to the *Expedite/CICS Display Application User's Guide*.

The default values for each command are provided in the command descriptions in Chapter 6, "Using Expedite/CICS commands in your application."

Commands directly supported by Expedite/CICS

Expedite/CICS directly supports most Information Exchange commands to simplify your application interface with Information Exchange. These commands can be identified as Information Exchange commands by their prefix SDI. This means Expedite/CICS provides command validation and command response processing, as well as restart and recovery features, when applicable.

When the command processor (EXPOICMD) receives one of these commands, it uses the field information supplied and default values from Expedite/CICS to format the appropriate Information Exchange command. You can override some of these default values when submitting commands to the Command Processor Information about setting user session defaults is provided in the *Expedite/CICS Display Application User's Guide*.

Expedite/CICS provides other command-processor-supported commands which are not Information Exchange commands, but which provide necessary functions for Expedite/CICS to manage the data. For example, the Set Administrative Response File (EXPADMN) command identifies where the command processor logs Information Exchange system messages.

When processing is complete, the command processor places the return code and response in the EXPCRSP commarea and returns control to your application.



Note:

1. A complete list of directly supported commands is provided in Table 1 on page 7
2. Details about each command and command responses are provided in Chapter 6, "Using Expedite/CICS commands in your application."
3. For information about how to interpret Expedite/CICS responses, See "Command processor responses" on page 63.

Pass-through commands

The Expedite/CICS pass-through function enables you to send commands to Information Exchange that are not directly supported by the Command Processor. The commands listed below are pass-through only commands:

Command	Can be used to
SDIARTV	Retrieve archived groups of mail (page 168)
SDICNCL	Cancel mail that you have sent (page 178)
SDIINQM	Inquire about mail in your mailbox (page 220)
SDILTST	Load test messages (page 218)

The command processor does not edit or audit pass-through commands and does not provide them with default values, so your application must provide all values required to send a passthrough command to Information Exchange except the session access key. The Expedite/ CICS command processor inserts the session access key and builds the command from the data passed in the COMMAREA and the TSQ named in the PS-FNAM field. Table 6 shows the format of the COMMAREA your application must pass to the command processor module (EXPOICMD).

Table 6. COMMAREA format for pass-through command

Column	Size	Name	Description	Value
1	1	PS-PASS	Pass-through indicator	1
2	8	PS-FNAM	TSQ containing the rest of the command	TSQ name
10	2	PS-FTYP	File type	TS
12	1	PS-DTYPE	Data type	blank
13	8	PS-PAD2	Filler	blank
21	8	PS-COMMAND	Name of the command	Command name
29	8	PS-ACCNTNO	Account name	Account name
37	8	PS-USERID	User ID	User ID name
45	8	PS-SESSKEY	Session access key	blank

To send a pass-through command to Information Exchange, proceed as follows:

1. Place all field values listed in Table 6 except PS-SESSKEY in your application COMMAREA.
2. Place the remainder of the Information Exchange command following PS-SESSKEY into the TSQ. The TSQ format for each pass-through command is provided in Chapter 6, “Using Expedite/CICS commands in your application.”
3. Call the command processor with the following CICS command:

```
EXEC CICS LINK PROGRAM(EXPOICMD) COMMAREA(XXXXXXX) LENGTH(500) END-EXEC
```

where XXXXXX is the name of the working storage area in your program that contains the parameters for the command.

Command processor responses

Your application calls the command processor using an EXEC CICS LINK statement with the command information in the COMMAREA. The command processor always returns control to the calling program with a return code.

Commands passed to the command processor are edited for valid values. If an error is detected, an immediate response is issued and the command is not executed. Your application must examine the return code to determine if the command processor successfully processed the command.

The command processor returns responses to a user program using the EXPCRSP COMMAREA format. Response code (RSPCODE) and Severity code (RSPSVCD) are returned for all commands. The values for the other fields of this COMMAREA depend on the response code and the pass-through indicator. The response code can be used to determine whether or not the command was successfully processed. The RSPSVCD field indicates the severity of the message being returned. Refer to *Expedite/CICS Messages* for more information.

COMMAREA format for response HI000 or HI001

The command processor returns the EXPCRSP COMMAREA to the calling program with the following fields for a directly supported command that was successfully submitted to Information Exchange.

Table 7. Response HI000 or HI001 COMMAREA format

Column	Size	Name	Description
1	5	RSPCODE	Response code
6	2	RSPSVCD	Response severity
8	243	RSPDATA	Response text

One of the following values is returned in the RSPCODE field:

- HI000** If the input to the command processor processed successfully, your program does not need to examine the remaining fields of the EXPCRSP COMMAREA. The RSPSVCD field contains zeros and the remainder of the COMMAREA (RSPDATA) contains spaces
- HI001** The input to the command processor may or may not have processed successfully. Your application needs to examine the response from Information Exchange. The RSPSVCD field contains the severity code and the RSPDATA field contains the response text. The command processor usually returns HI001 for an unsuccessful command execution, such as an SDIERR, but the Session Start command is an exception as the command processor returns HI001 to indicate successful completion for a Session Start.

COMMAREA format for pass-through

The command processor returns the EXPCRSP COMMAREA with the following fields for a passthrough command that was successfully submitted to Information Exchange.

Table 8. COMMAREA parameters for pass-through commands

Column	Size	Name	Description
1	5	RSPCODE	Response code
6	2	RSPSVCD	Response severity code
8	243	RSPQIN	Inbound queue
16	8	RSPQOUT	Outbound queue

HI001 in the RSPCODE field indicates the command was successfully submitted to Information Exchange and Information Exchange returned an immediate response. The RSPSVCD field contains zeros.

The RSPQIN and RSPQOUT fields contain TSQ names. The TSQ named in:

- RSPQIN contains information you passed to the Command Processor
- RSPQOUT contains information returned from the command processor, which may be an SDIERROR.



NOTE: It is your responsibility to delete both these TSQs

Processing errors

Expedite/CICS uses response messages to communicate processing errors and information. Expedite/CICS is designed to handle the following kinds of error messages:

- Expedite/CICS processing error messages
- Information Exchange processing error messages:
 - System error messages
 - SDIERR messages

Expedite/CICS processing error messages

When an Expedite/CICS processing error occurs, the command processor returns a message number to your application. Error messages are returned to the module that issued the command. Table 9 on page 65 describes the format for the messages that are returned.

COMMAREA format for response HIxxx

The command processor returns the EXPCRSP COMMAREA with the following fields if the command did not execute successfully.

Table 9. Response HIxxx COMMAREA format

Column	Size	Name	Description
1	5	RSPCODE	Response code; for example, HI421
6	2	RSPSVCD	Response severity; 00, 04, 08, or 12
8	3	RSPFILL	Filler
11	5	RSPTXTL	Response text length
16	x	RSPTXT	Response text; for example SESSION PROFILE DOES NOT EXIST

When the RSPCODE field contains a value other than HI000 or HI001, the input to the command processor did not process successfully. The error returned in RSPCODE is documented in *Expedite/CICS Messages*. The command processor pads error text in the RSPTXT field with spaces as needed.

The only exception to this is HI675, which indicates end of data for some commands. See Chapter 6, “Using Expedite/CICS commands in your application,” for more information.

Information Exchange processing error messages

System error messages

Generally, when Information Exchange detects an error in a command, it places a system error message in your mailbox. These messages are identified as being sent from Information Exchange address *SYSTEM* *ERRMSG*. These messages can be received with a Receive Message command.

Information Exchange system error messages may be information messages, such as acknowledgments, or they may be error messages. Information Exchange sends them to Information Exchange addresses complete with message headers, similar to those for data messages from other users. See “Understanding acknowledgments” on page 117 for the message format and a list of Information Exchange messages.

System messages received from Information Exchange are stored in your Expedite/CICS administrative response file (default = TSQ (EXPDRE1)).



NOTE: Expedite/CICS-supported commands perform command validation so that Information Exchange system error messages should not be produced.

SDIERR messages

Information Exchange cannot place certain errors in your mailbox. For example, if a command arrives at Information Exchange with an invalid Information Exchange address, an error message cannot be placed in your mailbox because the Information Exchange address does not exist. In such cases, an error response message is returned to Expedite/CICS. Information Exchange cannot process the input (beyond determining that it is invalid).

Some reasons why this error response message would be created are:

- The command name input to Information Exchange is not valid.
- The input command is too short to contain all required fields.
- No Information Exchange session was established for the Information Exchange address.
- The Information Exchange session access key is not valid.

Commands that normally receive immediate responses (Session Start, Session End, Commit, Session Inquiry, and Message Inquiry) may also receive an error response message instead of the normal response.

When an SDIERR message is returned to your application, the message is returned using the COMMAREA format shown in Table 10. The RSPCODE will be HI001 and SDI error messages will be in the WS-SDIERRC fields onward. The SDIERR layout is shown in Table 10 and is also included in the EXPCRSP copybook. Copybooks EXPERROR and EXPERRNUM are also provided to assist in processing SDI errors.



NOTE: Some SDIERR messages are converted to Expedite/CICS processing error messages, depending on the command.

Table 10. SDIERR message format using EXPCRSP copybook

Column	Size	Name	Description
1	5	RSPCODE	HI001
6	2	RSPSVCD	Response severity (00, 04, 08, 12)
8	8	WS-SDIERRC	This field identifies a message as an error response; it contains the character string SDIERRblankblank.

Table 10. SDIERR message format using EXPCRSP copybook

Column	Size	Name	Description
16	48	TEXT	<p>This field contains the (constant) text string THE FOLLOWING COMMAND WAS NOT EXECUTED BECAUSE: blank.</p> <p>This code: Indicates:</p> <p>1 The first eight bytes of the input did not contain a valid Information Exchange command name, or specified a command you are not authorized to use.</p> <p>2 The input was too short to process; it did not contain all required fields.</p> <p>4 No session was previously established for the Information Exchange address</p> <p>8 Invalid session access key</p> <p>16 Expansion level is invalid on a varying length command. Default cannot be determined.</p> <p>32 Fatal errors in command fields were found. Issue a Receive Messages command to determine which fields were wrong</p>
67	182	WS-SDIER-RREASON	This field contains the first 64 characters of the command that resulted in this message

Identifying what user programs must be developed

Figure 2 illustrates typical flow of data between an application and Information Exchange. In the diagram, User Program 1 is a program that invokes the Expedite/CICS command processor to issue a command. User Program 2 is the program to which Expedite/CICS links when the Receive Message command specifies a program name to be invoked for processing received data.

This topic explains how commands are issued by User Program 1 and how Expedite/CICS processes the request. This information will help you determine if you need to develop User Program 1, User Program 2, or both. If the Receive Message command specifies a file name in the RM-FNAM field as the destination for the received data, User Program 2 is not needed. User Program 2 is discussed in “Invoking a receive program internal to CICS” on page 109.

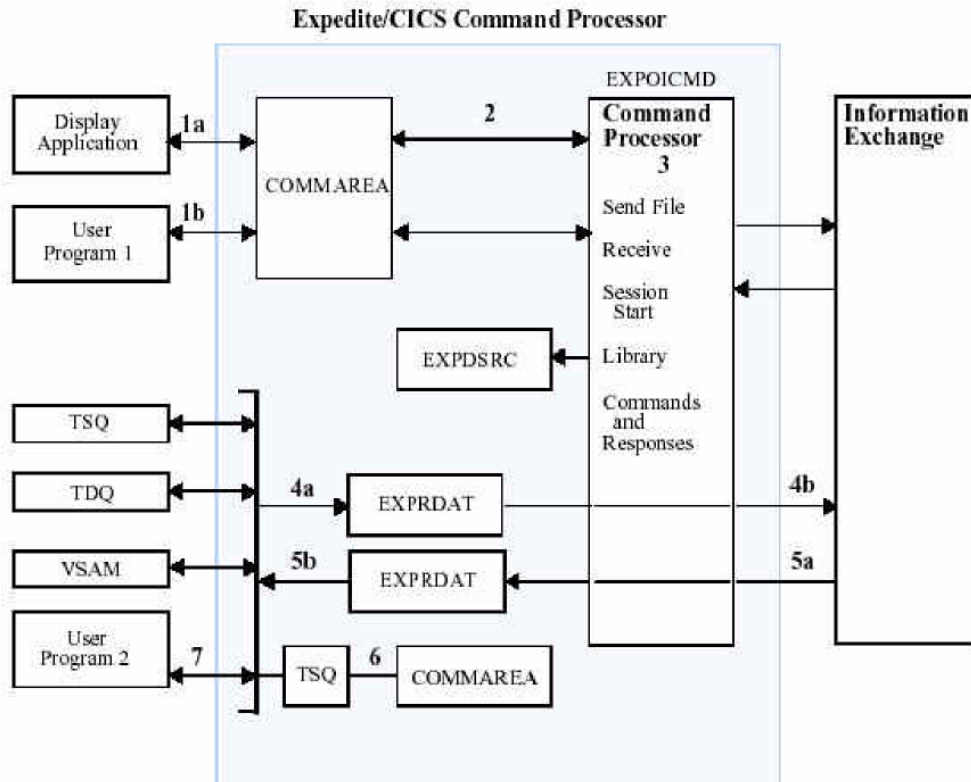

Figure 2. Typical flow of data between an application and Information

Exchange The items listed below correspond to numbered areas in Figure 3.

1. Expedite/CICS commands can be initiated from either of the following:
 - a. Display Application, as explained in the *Expedite/CICS Display Application User's Guide*.
 - b. User Program, as explained in Step 2.

2. To issue a command to Expedite/CICS, User Program 1:
 - Builds a COMMAREA, formatted as described in Chapter 6, “Using Expedite/CICS commands in your application.” A copybook is provided on the installation tape in the distribution library.
 - Issues: EXEC CICS LINK PROGRAM (EXPOICMD) COMMAREA (XXXXXXXX) LENGTH (500) END-EXEC.
 - Checks the response using the EXPCRSP copybook, as described in “Command processor responses” on page 63.
3. The command processor EXPOICMD:
 - Identifies the command in the COMMAREA.
 - Writes a control record to the EXPDSRC VSAM file for Send and Receive commands.
 - Sends the command to Information Exchange.
 - Passes the response to User Program 1.
4. When the command is a Send File request, Expedite/CICS:
 - a. Reads the data from the file specified in the SF-FNAM field, reblocks the data to the specified transmission size, and writes the data to the Send Data (EXPSDAT) VSAM file. If using compression, data is written in compressed format to the EXPSDAT file.
 - b. Forwards the file to Information Exchange for the Send, either synchronous or asynchronous.
5. When the command is a Receive Message request:
 - a. Information Exchange searches the mailboxes for messages that satisfy the request and sends the messages to Expedite/CICS, asynchronous.
 - b. Expedite/CICS writes the messages to the Receive Data (EXPRDAT) VSAM file before writing the message to the file name specified in the RM-FNM field. If using compression, data is in compressed format in the EXPRDAT file.
6. When the receive command specifies a program name in the RM-FNM field, Expedite/ CICS:
 - Reads the data from the receive data (EXPRDAT) file.
 - If receiving compressed data and compression support is installed, Expedite/CICS reads the compressed data from the EXPRDAT file and decompresses it. If compression support is not installed, Expedite/CICS attempts to deliver the data as it appears in the EXPRDAT file (compressed) and writes a message in the log.
 - Writes the data to a TSQ before linking to the receive program.
 - Links to the program using the name specified in the RM-FNM field.
 - Passes the program a COMMAREA which contains the name of the TSQ containing the data (see “Invoking a receive program internal to CICS” on page 109).
7. User Program 2:
 - Gets the name of the TSQ from the COMMAREA.

Designing an application

- Reads the TSQ and processes the data.
- Deletes the TSQ.
- Issues: EXEC CICS RETURN using the EXPCRSP copybook for the returning COMMAREA with HI000 to indicate successful completion or HIxxx to indicate an error.

Designing an application

Because objectives differ from application to application, it is difficult to define a rigid list of required commands. However, all Expedite/CICS commands issued from a user program to the Expedite/CICS command interface are invoked the same way. Expedite/CICS interprets which command is being issued by reading the COMMAREA which is created by the user program. This topic provides examples of commands a user program can issue and the responses it should check.

Chapter 6, “Using Expedite/CICS commands in your application,” describes commands that can be used to send and receive data from Information Exchange. The commands you need depend on application complexity. For example, an application might change user passwords at the beginning of each month. In this simple case, the only commands you need are Session Start and Session End.

To help you determine what commands your application might need, refer to the figures listed below, which illustrate typical command flow between an application and Information Exchange.

- Send File command processing in Figure 3
- Receive command processing in Figure 4
- Session Start command processing in Figure 5

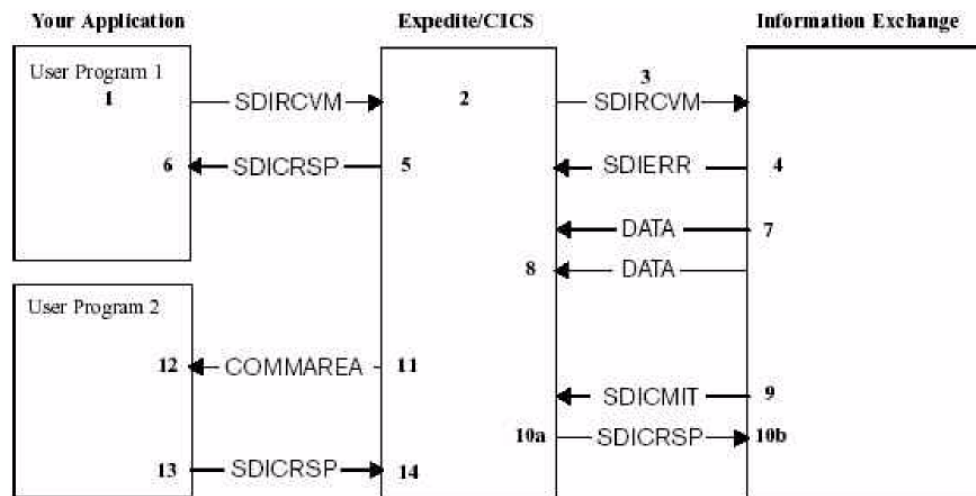



Figure 3. Send File command flow

Table 11. Example User Program COMMAREA parameters

User Program COMMAREA parameters			
SF-PASS	=0	SF-CACCT	=TRAD
SF-FNM SF-	=VSAMPOS	SF-CUSER	= PARTNER
FSTYPE SF-	=S	SF-CSKEY	= ''
DTYPE SF-	=O	SF-CDACCT	= AUTO
DISP SF-	=N	SF-CDUSER	= SUPPLY
FILR SF-	= ''	SF-CDTYPE	= D
CCMD	=XPSNDF	SF-COMPRES	= Y

The items listed below correspond to numbered areas in Figure 3.

- | Area | Description |
|-------------|--|
| (1) | Your application issues a Send File command, using copybook EXPSNDF COMMAREA parameters listed in Table 11 on page 70. |
| (2) | Expedite/CICS writes a control record to the EXPDSRC file and writes the send data to the send data (EXPSDAT) file. |
| (3) | If the value in Process send data field on the Define User Session Options panel is A (asynchronous) or, if the value in the SS-RECOV field of the Session Start command is A (asynchronous) or C (check-point), Expedite/CICS passes HI000 to your application before starting the Expedite/CICS send transaction to send the data to the user. |
| (4) | Expedite/CICS creates send-message headers, blocks the data at 26,000 bytes, sends the data to Information Exchange, and sends a Commit command to Information Exchange. |
| |  |
| | NOTE: The value at which data is blocked may vary from the default of 26,000 bytes, depending on what value is provided in the Data transmission size field of the Define System Options panel. |
| (5) | Information Exchange sends a response and commits the message |
| (6) | If the value in Process send data field on the Define User Session Options panel is S (synchronous) or, if the value in the SS-RECOV field of the Session Start command is S (synchronous) or M (message level), Expedite/CICS passes HI000 to your application after Information Exchange has committed the file. |

Area	Description
(7)	<p>Your application tests the response, using the EXPCRSR COMMAREA:</p> <ul style="list-style-type: none"> • HI000 means the command completed successfully; HIxxx means a command processing error occurred. For a list of send file response codes, see Chapter 6, “Using Expedite/CICS commands in your application.” • HI42 1 means you should issue a Session Start and reissue Send File. • HI504 or HI505 means you should issue a Session Start and reissue Send File. <p>To determine the cause of errors, you can:</p> <ul style="list-style-type: none"> • Inspect dump output. • Inspect the EXPM log for error messages. • Use the trace facility or EXPL log destinations to look for the cause of the error.

Sample program EXPSNDP1 is provided on the Expedite/CICS product tape in the distribution library. All updates to such sample programs are available in the Information Exchange libraries, as described in Appendix B, “Sample Programs”

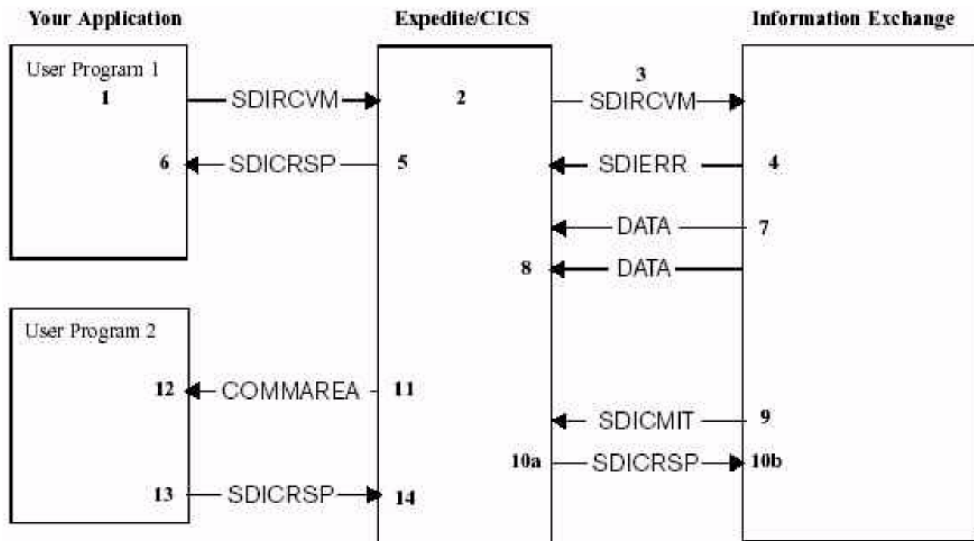

Figure 4. Receive Message Command Flow

Table 12. Example User Program COMMAREA parameter

User Program 1		User Program 2	
RM-PASS	= 4	EXIFNAME	= USRPGM2
RM-FNM	= USRPGM2	EXIFTYPE	= PG
RM-FTYPE	= PG	EXISRC	= Snnnnnn
RM-DTYPE	= A	EXICDH	= Snnnnnx
RM-DISP	= N	EXIPAD	= ''
RM-CNTL	= N	EXIACCT	= TRAD
RM-WRAP	= W	EXIUSER	= PARTNER
RM-LENG	= 80	EXIUCLAS	= USERCLASS
RM-TYPECMND	= C	EXIDTYPE	= O
RM-COMMAND	= SDIRCVM	EXILNGHD	= Information Exchange long header
RM-ACCTNO	= TRAD	EXISRC2	= Additional TSQ
RM-USERID	= PARTNER	EXISRCn	= Through n
RM-SESSKEY	= ''		
RM-REFNAME	= ''		
RM-DESTACCT	= AUTO		
RM-DESTID	= SUPPLY		
RM DESTTYPE	= D		

The following items correspond to numbered areas in Figure 4.

- | Area | Description |
|------|--|
| (1) | Your application, User Program 1, issues a Receive command using the EXPRCVM copybook parameters listed in Figure 12 on page 72. |
| (2) | Expedite /CICS completes the Receive command with user-specified parameters and writes a control record to the EXPDSRC file |
| (3) | Expedite/CICS issues the command to Information Exchange. |
| (4) | If an error occurs, Information Exchange generates an SDIERR response |
| (5) | Expedite/CICS passes the return code of the request to your application program using the EXPCRSP COMMAREA. HI000 indicates the Receive command was successfully issued to Information Exchange. |

- Area** **Description**
- (6) Your application tests the return code using the EXPCRSP COMMAREA. A normal return is as follows:

Column	Size	Content
1	5	HI000
6	2	00
8	1	S or C (single or continuous receive)
9	7	0000002 - 9999999



NOTE: Columns 8 and 9 make up the unique receive request control ID

- (7) Information Exchange searches the user mailbox for messages that match the request
- (8) Information Exchange sends data to the user (asynchronously), using REFNAME in the first 8 bytes of the Receive message header.
Expedite/CICS writes received messages to the receive data (EXPRDAT) file.
- (9) After a message group has been sent, Information Exchange sends a commit request to Expedite/CICS
- (10) Upon receiving a commit request from Information Exchange:
- Expedite/CICS checks the segment count and, if correct, sends a commit response to Information Exchange. Expedite/CICS is then ready to pass the data to User Program 2.
 - Upon receiving the commit response, Information Exchange does one of the following:
 - Sends the next message group (if more than one meets the receive criteria)
 - Sends an ENDDATA if there is no more mail in the mailbox and the request is a single receive. The request remains active if it is a continuous receive. An ENDDATA for a continuous receive request is sent when the receive is stopped by the user.
- (11) Expedite/CICS writes the data to a TSQ and passes the EXPRPGM COMMAREA, including the name of the TSQ, to User Program 2.
- (12) User Program 2 processes the data using the parameters listed in Table 12 on page 72 then deletes the TSQ.

Area	Description
(13)	<p>User Program 2 issues an EXEC CICS RETURN, passing HIxxx or HI000 in the first five bytes of the EXPCRSP COMMAREA.</p> <ul style="list-style-type: none"> For HI000, mark the control record as RECEIVED and delete the message from the receive data (EXPRDAT) file. For non-HI000, flag the control record in error and keep the data in the receive data (EXPRDAT) file.

The data is saved so it can be released and delivery retried when the error is corrected. Expedite/CICS marks the message in error and writes an error message to the Expedite/CICS log destinations and internal trace.

Sample programs User Program 1 (EXPRCVP1) and User Program 2 (EXPRCVP2) are provided on the Expedite/CICS product tape. All updates to such sample programs are available in the Information Exchange libraries, as described in Appendix B, "Sample Programs."

Figure 5 illustrates typical processing of a Session Start command.

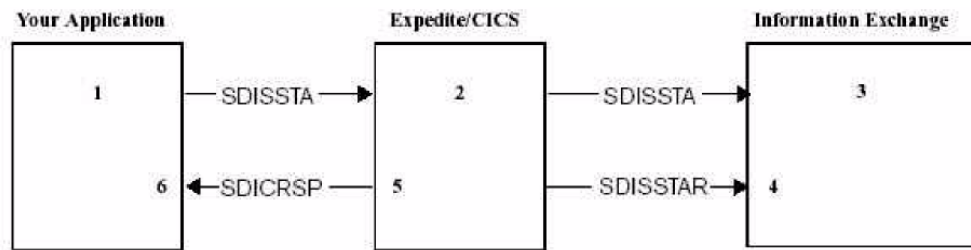

Figure 5. Start Session command flow

Table 13. Example User Program COMMAREA parameter

User Program COMMAREA parameters	
SSPASS	= 0
SSNAME	= SDISSTA
SSACCT	= ACCT
SSUSER	= USERID
SSPWD	= XXXX

The items listed below correspond to numbered areas in Figure 5.

Area	Description
(1)	Your application issues a Session Start command using copybook EXPSSTA; the required parameters are listed in Table 13 on page 74
(2)	Expedite/CICS does the following: <ul style="list-style-type: none"> • Find defaults in the Expedite/CICS user profile. If a user profile is not found and, if the value in the Auto create field is set to Y (Yes) in the system default profile, create a user profile using the SYSTEM DEFAULT model. • Complete the Session Start command with the user profile defaults. • Forward the Session Start command to Information Exchange.
(3)	Information Exchange does the following: <ul style="list-style-type: none"> • Perform user-validation. • Start a new user session or restart a session left previously.
(4)	Information Exchange issues a session start response to Expedite/CICS
(5)	Expedite/CICS attaches prefix HI001 to the Session Start response and forwards a return code to your application in the EXPCRSP COMMAREA.
(6)	Your application checks the return code using EXPCRSP COMMAREA for HI001 and checks the Session Start response code. A response code greater than 64 means the session was not started. If the return code is not HI001, refer to <i>Expedite/CICS Messages</i> . As a matter of convenience, some typical session start errors are provided in Table 14.



NOTE: You should design your send and receive application to first issue Send or Receive Message commands so that if an HI42 1 error, ACTIVE SESSION NOT FOUND, is received, the application will do a session Start. This ensures that active sessions are not overridden.

You should design your send and receive application to first issue Send or Receive Message commands so that if an HI42 1 error, ACTIVE SESSION NOT FOUND, is received, the application will do a session Start. This ensures that active sessions are not overridden.

Table 14. Typical session start errors

Typical Error messages	Program or recommended user responses
HI421 SESSION PROFILE DOES NOT EXIST	Create a user profile for the account ID and user ID specified on the Session Start command, or start a session because an active session does not exist.
HI423 USER PROFILE DOES NOT EXIST AND CANNOT BE CREATED.	Check the Auto Create User setting in the session options for the SYSTEM DEFAULT user ID. If the value is B (do not automatically create new users), you must create new user IDs yourself.

Typical Error messages	Program or recommended user responses
HI461 UNABLE TO ESTABLISH A SESSION WITH INFORMATION EXCHANGE.	The connection between your Expedite/CICS system and Information Exchange is either not in service or not acquired. Expedite/ CICS attempted unsuccessfully to put the connection back in service. Expedite/CICS writes a message to the log destinations and internal trace queues (EXPM and EXPL).
HI462 SESSION INFORMATION EXCHANGE HAS BEEN LOST.	The connection between your Expedite/CICS system and Information Exchange is working but Information Exchange encountered an error. Retry and, if the problem persists, call your local support group.

Session end considerations

When designing applications, you can choose either to end your user sessions or leave them active. The items listed below are provided to help you make this decision.

- If data is being sent or received, a request for a Session End is deferred until the request is complete. For receive requests, this means that an in-process receive is completed.
- A session end stops a continuous receive request.

If you choose to leave sessions active, Expedite/CICS automatically starts receives and asynchronous sends associated with active sessions during CICS startup. If you end sessions, you control the starting and stopping of receive requests.



CAUTION: If the same user ID starts a session from two systems, the second session overrides the first and Information Exchange communicates with the later session. This may cause a checkpoint failure because the counters between Expedite/CICS and Information Exchange are not the same. In addition, a session access key error may occur and messages may be delivered to a system other than the one intended. For these reasons, you should not share user IDs across systems.

Maximizing system performance

Messages are single threaded from Information Exchange; that is, Information Exchange does not send a new message for a user to Expedite/CICS until that user's last message is successfully received by Expedite/CICS and committed. Single threading ensures that messages are received in the order they were sent. Aside from this constraint, multi-tasking occurs in Expedite/CICS when:

- The same user ID is sending and receiving.
- Multiple user IDs are sending and multiple user IDs are receiving.
- Expedite/CICS receives a file from Information Exchange while writing the previous received and committed file to the user's destination in Expedite/CICS with similar occurrences on the send.

User IDs can send and receive at the same time, but you can reduce contention and enhance performance by using separate user IDs to perform send and receive tasks. Also, separate user IDs for test and production systems must be ordered.

Additional multi-tasking capability can be achieved by using multiple user IDs to perform sends, and multiple user IDs to perform receives. For example, different user IDs can be established to send or receive data based on data type or trading partner criteria.

Configuration alternatives

Your installation can be configured to use:

- A single user ID sending and a single user ID receiving, on a single Expedite/CICS system
- Multiple Expedite/CICS systems running on different CICS regions using multiple user IDs to communicate with Information Exchange
- Multiple Expedite products; for example, Expedite Base/MVS for batch processing, Expedite/PC and Expedite Base for AIX for associated platform support.

In regard to Expedite/CICS, you can create different application programs to process requests from different users, or process multiple users within the same program. The configuration you choose depends on your system processing constraints and the volumes of data to be processed. Your design alternatives include the following:

- **Interactive** panels, to be used for send and receive tasks. In this scenario, a user application puts data to be sent into CICS storage, the designated user logs on to the Expedite/CICS Display Application periodically to send or receive data. For details concerning send and receive tasks using the Display Application, refer to the *Expedite/CICS Display Application User's Guide*.
- **Automated** applications, to be used for send and receive tasks with no requirement for a user to log on to issue commands. How you use the Expedite/CICS program interface is explained earlier in this chapter.
- **Batch Interface**, to send data to Information Exchange that was previously created in a batch environment or to receive data from Information Exchange that can be processed later in a batch environment. The batch receive function is a Display Application option only. For more information, see Chapter 5, "Processing batch data using Expedite/CICS."

As you refine your installation, you must of course consider how often the process is to be used (continuously, daily, weekly, at a specific time interval or time of day, and so on).

Using the TCP/IP function of Expedite/CICS

In order to use the TCP/IP function of Expedite/CICS, you must have created the TCP/IP override parameter file EXPDPRM and added a DD statement for this file to your CICS startup job. You can use the sample job EXPDPRMX to create this file. Once it is created, you can edit the contents. When you bring up your CICS region again, the new version of the override parameter file will be processed.

The layout of the TCP/IP override parameter file is as follows:

1 - 3	4 - 7	8 - 22	23-27	28 - 35	36 - 40	41 - 45	46 - 60	61-65	66 - 68	69 - 71
TCP	0050	123.122.12.212	1900	TCPIPNAME	01500	00500	32.76.15.6	3001	002	003

In the override file, the record would appear as follows:

```
TCP0050123.122.12.212 1900TCPIPNAME015000050032.76.15.6 3001002003
```

In this example:

Field	Value used in this example	Valid values for this field
Communication Method	TCP	TCP or SNA
Maximum number of sockets (MAXSOC)	50	A number from 50 to 2000.
User IP Address	123.122.12.212	An IP address containing periods between each of the four octets, with no one octet exceeding 255.
User Port Number	1900	Any valid number
MVS Jobname of the TCP/IP address space on the user's system	TCPIPNAME	The jobname used for the TCP/IP address space (cannot be left blank).
Activity Timeout	01500	Format is HMMSS. H cannot be greater than 5, MM cannot be greater than 59, and SS cannot be greater than 59
Receive Timeout	00500	Format is HMMSS. H cannot be greater than 5, MM cannot be greater than 59, and SS cannot be greater than 59
Information Exchange's IP Address	32.76.15.6	An IP address containing periods between each of the four octets, with no one octet exceeding 255. It is the responsibility of the users to select the appropriate IE IP address based on their geographical location. (see note below)

Field	Value used in this example	Valid values for this field
Information Exchange's Port Number	3001	Any valid number. It is the user's users' responsibility to select the appropriate IE Port number based on their geographical location. (see note below)
Number of Send Sessions requested	002	Any valid number
Number of Receive Sessions requested	003	Any valid number

The Information Exchange IP addresses and port numbers are as follows:

Geographical region	IP Address	Port Number
USA (serving the US, Canada, and Latin America)	32.76.15.6	3001
EUR (serving Europe and Hong Kong)	194.32.223.47	3000
JPN (serving Asia Pacific, and Japan International. Does not include Australia or New Zealand)	166.100.65.33	3002
IEEX (serving Japan Domestic)	166.100.65.33	3003

TCP/IP override parameter field descriptions

Communication Method

The first three characters of the record represent the desired communication method. If they are SNA, the other parameters are not processed at all, and a record is written to TS Queue EXPTPARM indicating an SNA communication method.

If they are TCP, the remainder of the fields are processed for valid values. If an invalid value is encountered during the processing of the remaining parameters, and a default exists for that invalid parameter, the default is used. If an invalid value is encountered for a parameter which does not have a default, Expedite/CICS will stop processing the override parameter file and default the communication method to SNA.



NOTE: If you have entered what you believe to be valid values for your TCP/IP override parameters and Expedite/CICS brings up your region with a communication method of SNA, it is recommended that you turn on the trace option for "Startup parms" and recycle the region to find out which field is failing the validation process.

If Expedite/CICS is unable to process the value you enter, the default values listed in the table below will be used.

TCP/IP Override Parameter	Default value:
Communication Method	SNA
Maximum Sockets	50
Activity Timeout	30 minutes
Receive Timeout	10 minutes
Concurrent Send Sessions	1
Concurrent Receive Sessions	1

Maximum Sockets

This value represents the maximum number of sockets this application will ever have open at one time. The maximum number is 2000 and the minimum number is 50. This value is used to determine the amount of memory that will be allocated for socket control blocks and buffers. The default for this value is 50.

User's IP Address and Port Number

The user's IP address and port number are sent to Information Exchange on the TCP-Start command each time a user starts a session with Information Exchange using TCP/IP. Information Exchange needs this information to know where to send data to the user as a result of a single receive or continuous receive command.

MVS Jobname of the TCP/IP address space for the user's system

This information is required for Expedite/CICS to successfully perform an INITAPI with TCP/IP on the user's system.

Activity Timeout

This value represents the amount of time the Expedite/CICS user is willing to wait in case there is no activity on the line. The default is 30 minutes.

Receive Timeout

This value represents the amount of time the Expedite/CICS user is willing to wait for Information Exchange to send a reply. The default is 10 minutes.

Information Exchange's IP Address and Port Number

This information is used by the TCP/IP CONNECT command on the user's system to know where to connect to in order to send data.

Number of Send Sessions

This value represents the number of concurrent send sessions you would like to have at any given time with Information Exchange. Information Exchange will decide the final number (like the VTAM negotiations that are done for SNA), but this value is taken into consideration.

Number of Receive Sessions

This value represents the number of concurrent receive sessions you would like to have at any given time with Information Exchange. Information Exchange will decide the final number (like the VTAM negotiations that are done for SNA), but this value is taken into consideration.

Changing the override parameter values

For changes to the override parameter values from file EXPDPRM to be reflected in your CICS region, you must recycle your region. The override parameter file EXPDPRM is only read and processed upon startup.

Sending data to Information Exchange

Use the Send File command to send data to Information Exchange through the Command Processor. The name of the Send File command COMMAREA is EXPSNDF. Using EXPSNDF, you can send data from a temporary storage queue, an entry sequence VSAM data set, or a transient data queue. The data can be in one of the following formats.

This code:	Indicates records in:
A	CTRL format
B	LL format
E	EDI (X12, UCS, EDIFACT, or UN/TDI) format
O	Some other format

When you use a Send File command, specify parameter values that identify the recipient destination, the name of the storage facility that contains the data to be sent, and the type of data that is being sent. For details of how these parameters should be specified, refer to the command information provided in see Chapter 6, “Using Expedite/CICS commands in your application.”

For more information about data types, see “Send processing considerations” below.

Logical length (LL) type data is not supported by the product from Comm-Press, Inc. See Appendix C, “Using data compression,” for more information on data compression.

Send processing considerations

How Expedite/CICS processes data you send to Information Exchange depends on the type of data you send. Indicate the type of data you are sending by specifying a value in the SF-DTYPE field of the Send File command.

- Carriage-return line-feed (CRLF): Expedite/CICS inserts a 2-byte suffix (X'0D0A') as defined in the common data header field, if present, to the end of each record, and X'1A' to the end of the file.
- Logical Length records (LL): Expedite/CICS prefixes each record with a 2-byte length indicator.
- Electronic Data Interchange (EDI): One of the following formats: X12, UCS, EDIFACT, or UN/TDI. You can mix EDI-formatted messages within a single file, providing each message has a valid header and a trailer.
- OTHER (free format): Expedite/CICS sends the file to Information Exchange without examining or modifying the data. When using the Send Message command, this is the only acceptable data type.

Processing CRLF send data

If you use Expedite/CICS to send files to other personal computer users, you may want to reformat the data you send with ASCII CRLF to control the logical positioning of the delimiters. You can control the insertion of ASCII CRLF values into data currently stored in files that Expedite/CICS supports.

When you specify **A** in the **SF-DTYPE** of the Send File command, the command processor inserts CRLF delimiters (X'0D0A') when uploading data to Information Exchange, placing them at the end of each record. X'1A' is added as an end-of-file marker.

To control the logical positioning of CRLF indicators, reformat the length of the file. For example, if you want to insert a CRLF indicator at position 40, format the file you are sending with 39-byte records. The command processor reads each record and attaches the CRLF to the end of each record.

Processing logical length send data

When you specify **B** in the **SF-DTYPE** of the Send File command, the command processor places a 2-byte length indicator in front of each record it reads from an Expedite/CICS-supported CICS storage facility. For example, if a temporary storage queue returns a record length of 40, the command processor inserts the 2-byte length indicator at the beginning of the record, which indicates this value length.



NOTE: The 2-byte length indicator does not include the length of the length indicator field.

Processing OTHER send data

When Expedite/CICS processes a Send File command with data type **O** (**OTHER**), it places the data into a buffer and sends it to Information Exchange each time the buffer is filled. Expedite/CICS:

- Manages the long and short headers required.
- Does not place separators in the data.

This format is typically used when sending fixed-length records.

Processing EDI data

The topics under this header provide information about the different ways you can send EDI data using Expedite/CICS. Where you want to send the data is defined by the EDI destination field which may contain any of the following:

- An Information Exchange account ID and user ID.



NOTE: System ID is optional for EDIFACT and UN/TDI data

- An alias name that Information Exchange can resolve into an Information Exchange destination by using the Expedite/CICS translate table. This resolved destination may be an Information Exchange:
 - Account/Userid on the local system
 - Account/Userid on another system
 - Alias name to be resolved on a centralized Information Exchange alias table
 - A distribution list

You can use Expedite/CICS to send EDI data as illustrated in Figure 6.

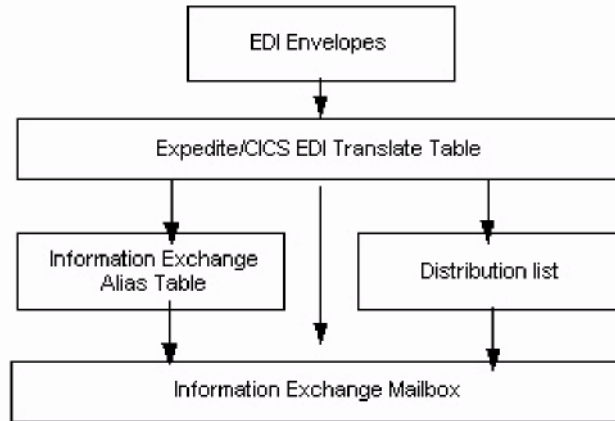

Figure 6. Sending EDI data

When you send EDI data using the Expedite/CICS Display Application or user program specifying file type E, Expedite/CICS inspects the EDI envelope and compares the destination information to entries in the EDI translate table. Expedite/CICS uses the EDI data type and information found in the table as needed to determine the Information Exchange destination.



NOTE: If multiple envelopes exist in a file, Expedite/CICS parses them and sends each as a separate file. Each envelope is treated as a separate file and each interchange is sent to Information Exchange based on the EDI destination in that particular envelope.

EDI envelopes

Expedite/CICS validates and then sends one EDI envelope at a time from a multiple-EDIenvelope file. Expedite/CICS inspects information in the EDI header and continues if the header is valid; otherwise, Expedite/CICS returns an error to the invoking application and stops processing the rest of the data in the file. The sender then must correct the data and resend messages from the point where the error occurred.



NOTE: For X12 data, Expedite/CICS continues to process even though an invalid ISA is encountered during a SEND. A message is written to the log and the envelope(s) in error to a TS queue. The user can then process or delete the queue(s).

To verify messages already sent and determine where processing should begin, the sender can view the:

- Completed send requests using the Expedite/CICS Display Application
- Send request audit trails on Information Exchange
- Expedite/CICS information exit information (if used)
- Returned error message in the exception log and trace destinations.

Similar procedures are followed when Verify before send has been specified. For more information, refer to the *Expedite/CICS Display Application User's Guide*.

Figure 7 provides an overview of send EDI processing when Verify before send = Y (Yes) was specified.

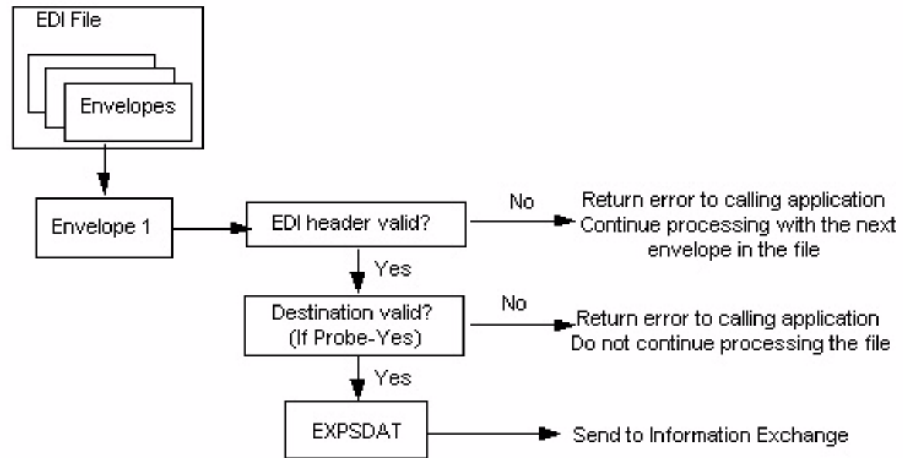

Figure 7. Send EDI processing

X12 data processing

When processing X12 data, Expedite/CICS looks for the beginning of the Interchange Control Header (ISA header). Expedite/CICS must find two items in the ISA header to continue processing:

- The Interchange receiver ID (can contain up to 15 characters)
- The Interchange ID qualifier (can contain up to 2 characters)

The Expedite/CICS command processor first determines whether it needs to translate the EDI destination identified in the ISA header into an Information Exchange address by using the values in the interchange ID qualifier field in the ISA header. If this field contains ZZ, Expedite/CICS searches the translate table for the EDI destination. The EDI destination can contain up to 15 characters. If there is no translate table entry, the Information Exchange destination is assumed to be a real account and user ID. If a real account and user ID is put in the data, the first 7 bytes are used for the account, and the next 8 bytes are used for the user ID.

If the interchange ID qualifier field contains a value other than ZZ, Expedite/CICS determines the EDI destination by using the translate table. If it does not find an entry in the translate table, Expedite/CICS writes a message to the error log and writes the envelope in error to a TS queue; then Expedite/CICS continues processing.

If the translation is successful, the command processor looks for the end of the current X12 envelope and parses the X12 data. The Interchange Control Trailer (IEA trailer) indicates the end of the X12 envelope. Expedite/CICS treats data between the ISA header and the IEA trailer as a complete Information Exchange message. The next ISA header in the file indicates a new message.

UCS data

When processing UCS data, Expedite/CICS looks for the BG* header. The BG* header contains the EDI destination of the message that Expedite/CICS needs to translate into an Information Exchange address. The EDI destination may contain up to 12 characters. Expedite/CICS must determine the Information Exchange destination using the translate table; otherwise, an error message is returned.

If the translation is successful, the command processor looks for the end of the current BG* envelope (indicated by the EG* trailer) and parses the UCS data. Expedite/CICS treats the data between the BG* header and the EG* trailer as a complete Information Exchange message. The next BG* header indicates a new message.



NOTE: UCS translations also need an EDI qualifier to translate the EDI destination. This EDI qualifier does not exist in the UCS data stream; if you define a translate table entry for UCS, the EDI qualifier field value must be **01**.

EDIFACT data

When Expedite/CICS processes EDIFACT data, it looks for a UNA or UNB header. The UNA header is used to define characters to use as delimiters and indicators in the rest of the interchange. The UNB header contains two values the command processor needs to continue processing:

- The Identification code qualifier up to four characters
- The Recipient ID, not counting character(s) separating the system ID, account ID, and user ID fields, if this is applicable

The command processor searches the translate table using both of these values to determine the message destination. The translation value is the interchange ID qualifier concatenated to the front of the Recipient ID field. If the ID qualifier is ZZ and the command processor cannot find a matching translate table entry it treats the Recipient ID as a real Information Exchange system ID, account ID, and user ID. The first 3 characters, starting at the first non-blank character, up to the first period, slash, or space, are used for the system ID (if present). The characters up to the next period, slash, or space (up to 8 characters) are used for the account ID. The next non-blank character begins the set of up to 8 characters that are used for the user ID.

If the interchange ID qualifier field contains a value other than ZZ, Expedite/CICS determines the EDI destination by using the translate table. If it does not find an entry in the translate table, Expedite/CICS stops processing and returns an error message.

If the translation is successful, the command processor looks for the end of the current EDIFACT envelope (indicated by a UNZ trailer) and parses the EDIFACT data. Expedite/CICS treats data between a UNA or UNB header and a UNZ trailer as a complete Information Exchange message. The next UNA or UNB header indicates a new message.

UN/TDI data

When Expedite/CICS processes UN/TDI data, it looks for the beginning of the SCH or the STX header. The SCH header is used to define the characters selected for use as delimiters and indicators in the rest of the interchange. The STX header contains the Transmission Recipient ID which determines the EDI destination of the file. The EDI destination may contain up to 35 characters, excluding character(s) separating system/account/user ID, if applicable.



NOTE: Because there is no EDI qualifier field in the UN/TDI header, the EDI qualifier field in the translate table should be left blank.

With UN/TDI data, the EDI destination (list, alias, Information Exchange system ID, account ID, and user ID) should be entered in the STX segment as illustrated in Figure 8. In the figure, Fields A and B taken together make up the Transmission Recipient field, which is also known as the UNTO data element. A and B may then be referred to as the First subelement and Second subelement, respectively, of the UNTO data element. The command processor must find a value in one of these fields in the Transmission Recipient data element before it can continue processing.

← A →
← B →

```
STX=ECEA:1+:account.userid+list/alias:sys.account.userid+920604...
```

Figure 8. UN/TDI STX segment

Only one of the two fields, A or B, is used depending on the addressing method used.

- If the sys.account.userid field is filled, Expedite/CICS sends to this real Information Exchange address. The first 3 characters, starting at the first non-blank character, up to the first period, slash, or space, are used for the system ID (if present). The characters up to the next period, slash, or space (up to 8 characters), are used for the account ID. The next non-blank character begins the set of up to 8 characters that are used for the user ID.
- If the list/alias field contains a list name or alias name, Expedite/CICS searches the translate table. A found entry is converted into an Information Exchange destination that will either be an Information Exchange Account/Userid or an Information Exchange alias, or a distribution list.

If Expedite/CICS finds the value identified in the recipient ID in the translate table to be a list name, command processor attempts to upload the list name. If the command processor cannot find the list name, it assumes it is a permanent distribution list on Information Exchange and sends the data to the list specified in the translate table.

- If both fields A and B are filled, A is used.

If the translation is successful, the command processor looks for the end of the current UN/TDI envelope (indicated by an END trailer) and parses the UN/TDI data. Expedite/CICS treats the data between the SCH or STX header and the END trailer as a complete Information Exchange message. The next SCH or STX header indicates a new message.

Defining how send data will be processed

This topic provides an overview of how Expedite/CICS processes send data requests. Send processing may be asynchronous or synchronous depending on the **Process send data** option specified on the Define User Session Options panel (see “Process send data” on page 26).

- When processing is asynchronous, control is returned to the user as soon as data to be sent is successfully loaded into the send data (EXPSDAT) file. Then the send data task is started. If a communication failure occurs, the send will be retried until successful. This type of processing enables multi-tasking to occur and maximizes performance because Expedite/ CICS can process another file or message into EXPSDAT while a previous file or message is being sent from EXPSDAT to Information Exchange.
- When processing is synchronous, data is sent under the initiating transaction (user transaction or LGO1 if using the Display Application). Control is not returned to the user until the send process completes and the whole message is sent to Information Exchange.

Asynchronous send processing

Asynchronous processing for a user session may be specified in the Expedite/CICS user session options field **Process Send Data**. The processing occurs as illustrated in Figure 9 and as described below.

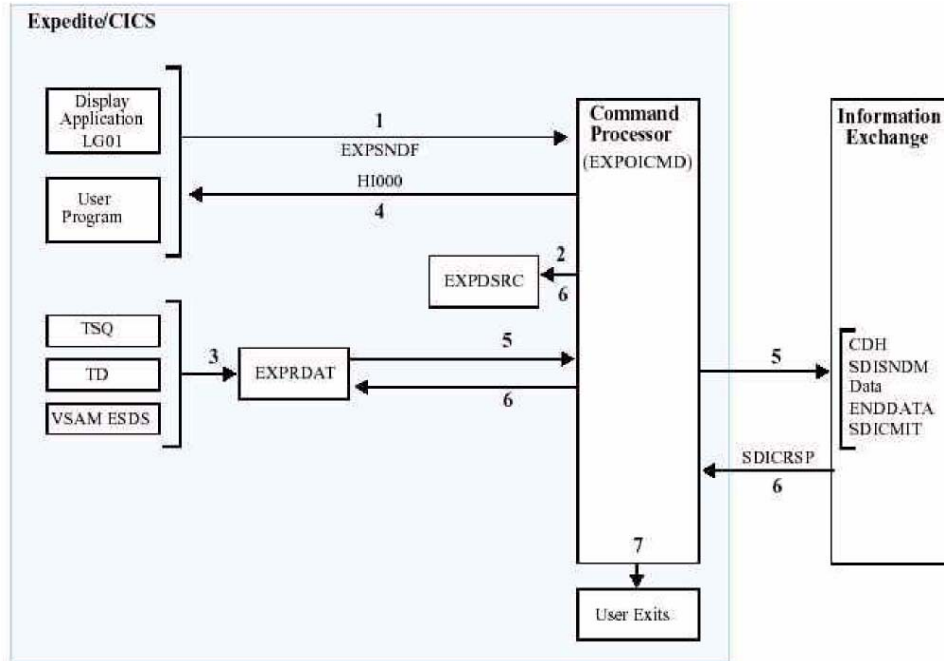

Figure 9. Asynchronous send processing

1. The send request is issued from either of the following:
 - a. Expedite/CICS Display Application
 - b. User program
2. The Display Application or user program invokes the command processor (EXPOICMD), which:
 - a. Identifies the command as a send request.
 - b. Writes a control record to the EXPDSRC VSAM file.
3. Expedite/CICS reads the data from the file specified in the SEND request and writes it to the send data EXPDAT file.
4. Expedite/CICS passes HI000 to the program that issued the send request, allowing the program to issue other commands while Expedite/CICS sends the message to Information Exchange.
5. Expedite/CICS:

- Starts transaction IST1 to begin Part 2 of the process:
 - Reads the data from the EXPSDAT file.
 - Sends the data to Information Exchange.
 - Attempts to commit the data to Information Exchange when the end of the data is reached.
- 6. If the commit response from Information Exchange is successful, Expedite/CICS marks the control record from EXPDSRC as SENT and deletes the message from the EXPSDAT VSAM file.

If an error occurs while sending the data to Information Exchange:

- For recoverable errors, such as if the link to Information Exchange is down, Expedite/CICS queues the message and retries the send until successful.
- For unrecoverable errors, Expedite/CICS:
 - Marks the send control record in EXPDSRC in error.
 - Writes an error message to the log destinations and to internal trace destinations if they are in use.
 - Retains the data in the send data (EXPSDAT) file until it is successfully released by the user and sent to Information Exchange, or deleted either by the user or by Expedite/ CICS after the number of days specified in the **Not-Sent Not-Received Retention** parameter on the Define System Options panel.
- 7. When the data has been sent to Information Exchange, Expedite/CICS can optionally link to the following:
 - User information monitor exit for performance data collection, if the link to the user exit is enabled
 - The user completion notification exit for notification of completed sends, if it was specified in the Send Message command. The return code of the Send command is passed to this program.

The send request for this message is now complete. For more information about additional EDI send processing, see “EDI envelopes” on page 84.

Synchronous send processing

Synchronous processing for a user session can be specified in the Expedite/CICS user session options field, Process send data. Processing occurs as illustrated in Figure 10 and as described below.

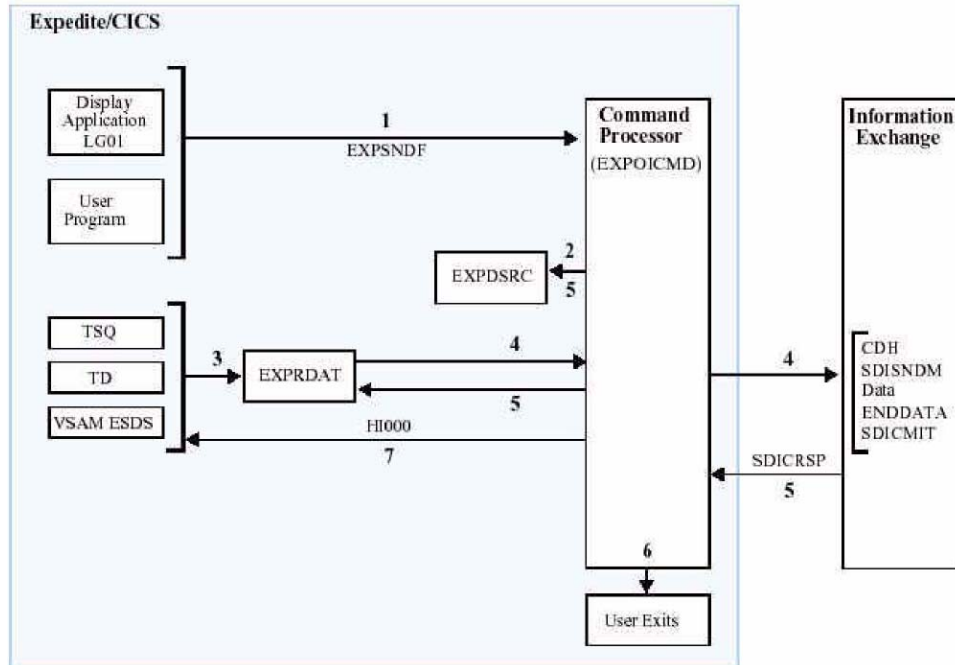

Figure 10. Synchronous send processing

1. The send request is issued from either of the following:
 - a. Expedite/CICS Display Application
 - b. User program
2. The Display Application or user program invokes the command processor (EXPOICMD), which:
 - a. Identifies the command as a send request
 - b. Writes a control record to the EXPDSRC VSAM file
3. Expedite/CICS reads the data from the file specified on the Send File command and writes it to the send data (EXPSDAT) VSAM file.
4. Expedite/CICS:
 - Reads the data from the EXPSDAT file
 - Sends the data to Information Exchange
 - Attempts to commit the data to Information Exchange when the end of the data is reached.

5. If the commit response from Information Exchange is successful, Expedite/CICS marks the control record from the EXPDSRC file as SENT and deletes the message from the EXPSDAT file.

If an error occurs while sending the data to Information Exchange, Expedite/CICS:

- Marks the send control record in EXPDSRC in error.
 - Writes an error message to the log destinations and to internal trace destinations if they are in use.
 - Deletes the data from the EXPSDAT file.
 - Returns HIxxx to the program that issued the send request.
6. When the data has been sent to Information Exchange, Expedite/CICS can optionally link to the user completion notification exit for notification of completed sends, if it was specified in the Send Message command. For synchronous processing, there is no optional link to the user monitor information exit.
 7. Send processing is now complete. Expedite/CICS passes HI000 to the program that issued the send request.

Processing send request errors

For both synchronous and asynchronous processing, if an error occurs while loading data into the send data (EXPSDAT) file, control is returned to the user with an appropriate error message and the file is not sent.

Asynchronous processing:

If an error occurs after the file is stored in the EXPSDAT file, the data records are retained in EXPSDAT. For recoverable process interruptions (for example, link or connection failures), Expedite/CICS queues the file until it is sent successfully. Process interruptions in this category include:

HI461	Unable to establish a session with Information Exchange
HI462	Session with Information Exchange has been lost
HI464	Send checkpoint numbers are out of synchronization
HI467	Unexpected commit response code > 07; refer to Information Exchange error messages
HI500	An error was incurred when receiving the commit response
HI509	Unable to send the message to Information Exchange

All the error messages listed above are recoverable for asynchronous send requests. Because Expedite/CICS keeps trying the send until successful, no user action is required.

Unrecoverable errors that occur only due to Expedite/CICS system problems are marked in error and the send control and data records remain stored in the send data (EXPSDAT) file until purged or released by the user and the send request is reissued. An error message is written to the log destinations and to internal trace destinations if they are in use. For information about manual release of failed send requests, see the *Expedite/CICS Display Application User's Guide*.



NOTE: If a Send request completed in error and you used the optional link to the user completion notification exit for notification of completed send requests, the return code is passed to the exit program.

Any incomplete send, not marked as having an unrecoverable error, is restarted during a session start, session restart, or session reset when the user session profile indicates asynchronous processing. For more information on restart and recovery, see Appendix A, “Understanding automated restart and recovery.”

Active, queued, and completed sends (whether in error or successfully sent) can be viewed and purged from the Display Application Process and View panels as described in the *Expedite/CICS Display Application User's Guide*.

Synchronous processing:

If an error occurs while sending data, the file is marked in error and the data records are deleted. An error message is written to the trace destinations. A return code is sent to the user, who is then responsible to reissue the send. The error code can be viewed from the Display Application as described in the *Expedite/CICS Display Application User's Guide*.

For more information, see Appendix A, “Understanding automated restart and recovery,” and the *Expedite/CICS Display Application User's Guide*.

Send processing options

The topics under this heading discuss some send processing options you may choose to use.



NOTE: The Send File command also provides parameter fields in which you can specify a user exit program to process send request completion notification. For more information, see “Expedite/CICS completion-notification acknowledgments” on page 122.

Requesting Information Exchange acknowledgments

You can request Information Exchange acknowledgments for Send commands you issue by specifying the type of acknowledgment you want in the SF-CRCPT field of the Send command. You can request three types of acknowledgments:

For type	Information Exchange generates an acknowledgement when:
Receipt	A message reaches a receiver's mailbox



NOTE: A message is purged if it is not received within the number of days specified in the Send File in the **Message retention** field.

For type	Information Exchange generates an acknowledgement when:
Delivery	A user successfully receives a message from the Information Exchange mailbox.
Purge	A message is purged from the receiver's mailbox

Although they are not error messages, Information Exchange places these acknowledgments in the sender's mailbox, sent from the *SYSTEM* *ERRMSG* Account/Userid. For more information about how to receive and interpret these messages, see “Understanding acknowledgments” on page 117.

Forcing receive criteria

When sending files, you can use the **Force Receive Criteria** field to indicate whether the recipient must provide specific criteria that relates to your file in order to receive it. This can be used, for example, to help ensure that your file is not overlooked by the recipient during receives. If you specify Y in this field, the file cannot be received until the recipient provides specific receive criteria that apply to the item you sent.

Defining data transmission size

The command processor buffers processed data, based on data type, and forwards it to Information Exchange using the value in the System Options panel in the **Data transmission size** field. The valid range is 3,700 to 26,000. The user must take into consideration the size of the CICS journals when setting this field; particularly the buffer size, which must be large enough to handle the transmission size plus the journal headers (approximately 200 bytes).

Unless you change the default during installation, the command processor parses messages into Information Exchange message segments of 26,000 bytes, or the maximum message size supplied by your Information Exchange system. See the Expedite/CICS Display Application User's Guide for more information on how to define data transmission size.

You should also consider your message group size in your user profile when defining data transmission size.

Assigning a message user class

You can provide a value for the User class parameter from the Expedite/CICS Display Application or from a user program. A user class is a definition you and your trading partners choose to identify the kind of information contained in files and messages you exchange. A user class identifier is alphanumeric, left-justified, and not longer than eight characters. Examples of valid names include: PAYROLL, INVOICES, and PROGRAM1.

User classes can be used to categorize mail from different trading partners. For example, customers might send mail identified as user class, CUSTOMER, while vendors might identify their mail with user class, VENDOR. When sending EDI data, if you do not specify a value in the user class field (**SF-CUMSGC**), it is generated from the EDI data as described below.

EDIFACT and UN/TDI data

For EDIFACT and UN/TDI data, Expedite/CICS takes the class from the Application reference field (APRF) of the EDI data. If the APRF is longer than eight bytes, the first eight bytes are used. If the APRF is shorter than eight bytes, Expedite/CICS places the APRF in the message user class field, left-justified and padded with blanks. If the APRF is not present, Expedite/CICS sets the message user class parameter as described in the table below.

Table 15. Message class processing for EDIFACT and UN/TDI data

This EDI data type:	Defaults to this class:
EDIFACT	#EE
UN/TDI	#EU

X12 and UCS data

For X12 and UCS data, Expedite/CICS sets the message user class parameter as follows:

Table 16. Message class processing for X12 and UCS data

This EDI data type:	Defaults to this class:
X12	#E2
UCS	#EC

Compressing data

You can control data compression with the SF-COMPRESS parameter. The values allowed are as follows:

This value:	Indicates:
Y	Compress
N	Do not Compress
T	Use the lookup table. If the sender/receiver pair is found in the table and Compress equals Y , then compress. If Compress equals N , or it is not found, then do not compress.

Logical length (LL) type data (File Type=B) is not supported by the Comm-Press product. Expedite/CICS returns a message if compression is attempted with this type of data.

Specifying Information Exchange control fields

If you issue a Send command from a user program, you can specify values for a unique ID, Message name, and Message sequence number control fields. The field names are **SF-UNIQUE**, **SF-MSGNAME**, and **SF-MSGSEQN**, respectively. When sending EDI data, if you do not specify these fields in the send request from a user program or if you use the Display Application, the fields are generated from the EDI data. Each of these options is discussed in subsequent topics.

UNIQUEID assignment

A UNIQUEID value can be assigned by a user application and used with other field values (for example, Message name, Message sequence number, destination, and user class) of a Send File command to uniquely identify the message for Send Message completion and acknowledgments. For more information, see “Understanding acknowledgments” on page 117.

Message name assignment

If you do not provide the message name parameter, Expedite/CICS generates the Information Exchange message name based on the type of EDI data transmitted as described in the table below. Table 17 describes how this is accomplished.

Table 17. Message name processing

This EDI data type:	Generates this message name:
EDIFACT	Expedite/CICS takes the message name from the data element 0020 (Interchange Control Reference) of the EDI data. If the element exceeds eight bytes, Expedite/CICS uses the first eight bytes. If the element is shorter than eight bytes, Expedite/CICS places it in the message name parameter value, left-justified and padded with blanks.
UN/EDI	Expedite/CICS takes the message name from the sender's reference field (SNRF) of the EDI data. If the SNRF exceeds eight bytes, Expedite/CICS uses the first eight bytes. If the SNRF is shorter than eight bytes, Expedite/CICS places it in the message name parameter value, left-justified and padded with blanks.
X12	Expedite/CICS takes the message name from the last eight bytes of the interchange control number of the X12 data.
UCS	Expedite/CICS takes the message name from the interchange control number. Because the UCS interchange control number has a maximum length of five bytes, Expedite/CICS places the interchange control number in the message name parameter value, left-justified and padded with blanks.



NOTE: These fields are not displayed on the Display Application panel but are copied to the Information Exchange audit records. The field contents are returned in Information Exchange acknowledgments and can be viewed or retrieved using Information Exchange Administration Services.

If the message name field is left blank in the EDI data, Expedite/CICS leaves the field blank.

Message sequence number assignment

If you do not provide the message sequence number parameter, Expedite/CICS generates the Information Exchange message sequence number as described in Table 18 on page 96.

Table 18. Message sequence number processing

This EDI data type:	Generates this message name:
EDIFACT	Expedite/CICS takes the message sequence number from data element 0022 (Recipient Reference). If the element is longer than five bytes, Expedite/CICS uses the first five bytes. If the element is shorter than five bytes, Expedite/CICS places it in the message sequence number field, left-justified and padded with blanks.
UN/TDI	Expedite/CICS takes the message sequence number from the Recipient Reference field (RCRF:1). If the element is longer than five bytes, Expedite/CICS uses the first five bytes. If the element is shorter than five bytes, Expedite/CICS places it in the message sequence number field, left-justified and padded with blanks.
X12	Expedite/CICS places a value of 00001 in this field if there is only one X12 envelope in the file. If the file contains more than one X12 envelope, the value is incremented by one for each envelope. This is explained in more detail below.
UCS	Expedite/CICS places a value of 00001 in this field if there is only one UCS envelope in the file. If the file contains more than one UCS envelope, the value will increment by one for each envelope. This is explained in more detail below.



NOTE: These fields are not displayed on the Display Application panel but are copied to the Information Exchange audit records. The field contents are returned in Information Exchange acknowledgments and can be viewed or retrieved using Information Exchange Administration Services.

For EDIFACT and UN/TDI: If the message sequence number field is left blank in the EDI data, Expedite/CICS leaves the field blank.

For X12 and UCS: Expedite/CICS counts each EDI envelope transmitted from a single data file. It places the count in the message sequence number of each Information Exchange message corresponding to an EDI envelope. Expedite/CICS formats message sequence number as a series of numeric characters ranging from 00001 to 99999. Therefore, three EDI envelopes sent from a single file would have the following message sequence number values:

- 00001 for the first EDI envelope in the file
- 00002 for the second EDI envelope in the file
- 00003 for the last EDI envelope in the file

Each time you use Expedite/CICS for a new file that contains EDI envelopes, or when the count reaches 99999, the message sequence number counter resets to 00001.

Specifying the common data header

Information Exchange interfaces can use a common data header (CDH) to communicate detailed information about files and messages to other interfaces. Expedite/CICS builds a CDH for every message and file that is sent and recognizes CDHs received from other interfaces. This subject is explained in more detail in “Information Exchange Common Data Header (CDH)” on page 132.

Receiving data from Information Exchange

Your application can invoke a receive request by issuing the Receive Message command (EXPRCVM) to receive messages, files, and responses placed in your Information Exchange mailbox.

Receiving messages and files

Messages and files are placed in your Information Exchange mailbox by your trading partner. Your application must issue a Receive Message command, using the EXPRCVM copybook, to receive them.

Force selective receive

When receiving files that have been sent with the Force Selective Receive option, your application must issue selective receive criteria that apply to them. Issuing a receive command without selection receive parameters, such as message user class or account code and user ID, does not receive them.

Receiving responses in your mailbox

Mailbox responses are not immediately returned to your application, but are placed in your Information Exchange mailbox from an Information Exchange Account/Userid such as *SYSTEM* *LSTRSP*. “Receiving mailbox responses” on page 9 lists commands that generate mailbox responses. Information Exchange acknowledgments and error messages are also placed in your mailbox as a mailbox response from Account/Userid *SYSTEM* *ERRMSG*. For more information, see “Understanding acknowledgments” on page 117.

Your application can selectively receive mailbox responses by issuing the Receive Message command using the EXPRCVM copybook with the following parameter specifications (for example):

- *SYSTEM* in the **RM-DESTACCT** field
- *LSTRSP* in the **RM-DESTUID** field

To receive mailbox responses along with all other messages in your mailbox, issue the Receive Message command, leaving the **RM-DESTACCT** and **RM-DESTUID** fields blank.

All responses from account, *SYSTEM*, except those from user *AUDITS*, are placed in the administrative response file, which is defined in your user profile, not in the destination specified in the Receive command. For more information, see the section on Receiving system messages in the *Expedite/CICS Display Application User's Guide*. All responses from *SYSTEM* *AUDITS* are placed in the destination specified in the Receive Message command.

Receiving acknowledgments

To retrieve acknowledgments from your mailbox, use a receive command to receive from Account/Userid, *SYSTEM* *ERRMSG*. Messages from the Account/Userid are delivered to the response destination specified in your user profile, not the destination specified in the receive command. Acknowledgments can be parsed and interpreted as described in Table 21 on page 117, under “Understanding acknowledgments” on page 117.

Receive processing considerations and options

Expedite/CICS provides two types of receive processing:

- **Single Receive:** Downloads messages or files meeting the receive command criteria, and ends.
- **Continuous Receive:** Continuously downloads messages or files meeting the receive command criteria. A user receives all requested data in the mailbox at the time the request is issued and the receive remains active until the user stops the continuous receive or ends the session.



NOTE: You can issue multiple single receives and continuous receives simultaneously.

Requesting a single or continuous Receive

To start either a single or continuous Receive, your application must pass a Receive Message command to the command processor using the EXPRCVM copybook specifying **S** or **C** in the **RM-TYPECMDND** field. Your application must format the EXPRCVM copybook and issue a LINK command as shown in the following example:

```
EXEC CICS LINK PROGRAM (EXPOICMD) COMMAREA (xxxxxxxx) LENGTH
(500) END-EXEC
```

where xxxxxxxx is the name of the working storage area in your program.

The fields for the COMMAREA are described in Chapter 6, “Using Expedite/CICS commands in your application,” and a soft copy of the EXPRCVM copybook is provided on the Expedite/ CICS installation tape. The command processor formats the command, supplies required defaults, and passes the parameters to the receive request function, which issues the Receive command to Information Exchange.

Stopping a continuous receive

To end a continuous receive, issue the Receive command again with the RM-TYPECMDND field changed to E. All other fields should contain the same values as when the continuous receive was issued.

When a Stop Continuous Receive is issued while Expedite/CICS is actively receiving data, the Stop Continuous Receive is queued until Expedite/CICS completes receive processing.

Restarting a continuous receive

If a continuous receive is active and CICS or Information Exchange goes down, it is not necessary to reissue the continuous receive unless you issued a stop continuous receive request or a session end. Expedite/CICS restarts all sessions that were active when CICS went down. Therefore, it is conceivable you could issue a continuous receive and never stop it or reissue the command. For more information, see Appendix A, “Understanding automated restart and recovery.”

Defining a receive destination

To complete a single or continuous receive command, you must indicate how data received from Information Exchange will be managed. Specify the following fields in the EXPRCVM copybook:

- In **RM-FNM**, specify a file name or the program name of your receive application.
- In **RM-DTYPE**, specify the data type; this indicates the type of processing to apply to received data.
- In **RM-FTYPE**, specify the type of storage to be used: VSAM ESDS, transient data queue, temporary storage queue, or program.

To avoid confusion, unique names should be used for each of the above storage facilities. Users should not share file names and their associated file types. If you receive messages for different applications into the same destination, your program must identify the applications to which the data corresponds.



NOTE: You can use different destinations for different application data.

Receive processing field specifications

This topic discusses some receive processing considerations, providing general recommendations for using the receive options and explaining how field input conflicts are resolved. Complete field descriptions are provided in Chapter 6, “Using Expedite/CICS commands in your application.”

The following four parameters must be considered when you use the Expedite/CICS single or continuous receive functions:

- File type (**RM-DTYPE**)
 - Handle records as (**RM-WRAP**)
 - Retain header data (**RM-CNTL**)
 - Max record length (**RM-LENG**)

The values assigned to these parameters and the way the parameters interact affect the way Expedite/CICS formats the incoming data and the processing speed with which the data is written to the receive destination. Some of these values can be specified in two places; for example, Expedite/CICS can get input for data type from both the **File type** field and from the CDH. The fields described below will help you understand how field input conflicts are resolved.

For more information about Receive options, see “Receive processing considerations and options” on page 99.

Specifying a file type

The **File type** field value can be: **A** (CRLF), **B** (LL), **E** (EDI), or **O** (OTHER).

Data is formatted according to the **File type** field if the value in **Retain header data** is **N** or **Y** and the value in **Handle records as** is **V** (the value in **Max record length** is then ignored). Any other values in these fields can further affect how the data is written to the receive destination.

When **File type** option **O** is specified, it is recommended that the value in **Handle record as** is set to **W** or **S**, to write the data as continuous fixed records.

Trying to receive data with **File type** option **A** or **B**, when the data does not contain CRLF or LL delimiters, results in an error. See “Processing received data” on page 101 for more information.

Specifying how records should be handled

The **Handle records as** field value may be **V** (Variable), **S** (Split), or **W** (Wrap):

If the value in **Handle records as** field is **W** or **S** and the value in the **Max record length** field is not zero, these two values are only used if the **Retain header data** field has a value of either **N** or **Y**. In this case, the records are handled according to the value in the **Max record length** field.

For example, if data is sent with CRLF at 80 bytes and is received with:

File type = A, Handle records as = W, and Max record length = 40, the data is wrapped at 40-byte records and not 80-byte records.

Specifying maximum record length

The **Max record length** field values may range from 00000 - 28000 bytes.

The value in **Max record length** is ignored when the value in **Handle records as** is **V** (Variable). **V** should be specified in the **Handle records as** field to store individual records when **File Type** option **A** or **B** is used.

Specifying the retain header value

The **Retain header data** field value may be **N**, **Y**, **E**, or **F**.

If the value in **Retain header data** is **F** or **E**, this information takes precedence over all other receive options. For example, if the CDH indicates data was sent with **File type=B** to indicate LL data, and you specify receive **File type=O** and **Retain header data=F**, Expedite/CICS uses the CDH information, strips the delimiters, and receives as **File type=B**.



NOTE: The main CDH fields which determine how to process the data are the Record delimiter, Data format, Record format, and Record length. The CDH Record delimiter field indicates whether data is delimited by CRLF, LLs, or is EDI-delimited. For EDI, the EDI data type is indicated in the Data Format field.

Retain header data values of **F** and **Y** are exactly the same as values **E** and **N**, respectively, except that, with the former values, the Information Exchange headers are also written to the receive destination; that is, one long header at the start of a mail item and one short ENDDATA when the receive has ended. An exception is that, when data is processed as EDI data, the received Information Exchange headers are not written to the destination.

When data does not have a CDH, specifying **Retain header data** option **E** or **F** gives the same result as if option **N** or **Y**, respectively, were used.

There are no fields in the receive command to specify decompression. Expedite/CICS determines from the CDH if the data is compressed and automatically decompresses it. See Appendix C, “Using data compression,” for more information on compression.

Processing received data

Expedite/CICS processes data received from Information Exchange according to data type, so you must indicate the data type in the **RM-DTYPE** field of the Receive Message command.

This code	Indicates this data type
A	CRLF
B	LL
E	EDI data (X12, UCS, EDIFACT, or UN/TDI format)
O	OTHER

See “Managing data” on page 10 for more information.

If you specify an incorrect data type, the message is marked in error and is not delivered to the requested destination file. For example, if you specify X12 and the incoming data is CRLF, no ISA header is found and the message is marked in error. See “Receive error processing” on page 106 for more information.

Processing CRLF receive data

When **A** is specified in the **RM-DTYPE** field of a Receive Message command, Expedite/CICS looks for the record delimiter X'0D0A' or the delimiter specified in the common data header. As the beginning and end of each record is found, Expedite/CICS removes the delimiter and writes each record to the user's destination. Expedite/CICS also removes the end-of-file indicator.

What Expedite/CICS does with the first Information Exchange long header and last Information Exchange ENDDATA is determined by the value in the **RM-CNTL** field. If the value is **Y** or **F**, the first Information Exchange long header for each mail item is written to the user's destination at the beginning of the data and the last Information Exchange ENDDATA is written to the user's destination when the receive has ended.

Processing logical length receive data

When **B** is specified in the **RM-DTYPE** field of the Receive Message command, Expedite/CICS looks for a two-byte length indicator at the beginning of each record. As enough data is received to satisfy each length indicator, Expedite/CICS removes the indicator, and writes the data record to the user's destination file.

What Expedite/CICS does with the first Information Exchange long header and last Information Exchange ENDDATA is determined by the value in the **RM-CNTL** field. If the value is **Y** or **F**, the first Information Exchange long header is written to the user's destination at the beginning of the data and the last Information Exchange ENDDATA is written to the user's destination when the receive is ended.

Processing EDI receive data

When you specify **E** in the **RM-DTYPE** field or, when you specify **E** or **F** in the **RM-CNTL** field, Expedite/CICS determines the EDI data type (X12, UCS, EDIFACT, or UN/TDI) from the data or the CDH. Expedite/CICS then processes the data according to the EDI data type as explained below. Values in the **RM-CNTL**, **RM-WRAP**, and **RM-LENG** fields of the receive message command or values in the CDH, if processing is based on this, may further affect how the data is written to the destination.

Refer to the *Expedite/CICS Display Application User's Guide* for further details on receive processing options and considerations.

X12 data: Expedite/CICS looks for the beginning of the ISA header, which contains the segment delimiter needed to separate each transaction properly. When the envelope segment delimiter is determined, Expedite/CICS saves it in the session profile.

As the beginning and end of each X12 transaction is found, Expedite/CICS removes the Information Exchange long and short receive headers from the data and writes each transaction to the user's destination file. The data is split and written by EDI segment.

UCS data: Expedite/CICS looks for X'15', the segment delimiter contained by all UCS envelopes. As the beginning and end of each UCS transaction is found, Expedite/CICS removes the Information Exchange long and short receive headers from the data and writes each transaction to the user's destination file. The data is split and written by EDI segment.

EDIFACT or UN/TDI data: Expedite/CICS looks for the beginning of the UNA or UNB header for EDIFACT messages or the SCH or STX header for the UN/TDI messages. Expedite/CICS removes the Information Exchange long and short receive headers from the data, parses the data into 80-byte records, and writes the records to the user's destination file.

Processing OTHER receive data

Expedite/CICS does not manipulate data when the RM-DTYPE field contains O but does the following:

- Removes all the Information Exchange headers from the data received.
- Places each transmission into a separate item or record.
- Wraps the data according to the record length specified in the RECEIVE MESSAGE command **RM-WRAP** and **RM-LENG** fields.

What Expedite/CICS does with the first Information Exchange long header and last Information Exchange ENDDATA is determined by the value in the RM-CNTL field. If the value is Y or F, the first Information Exchange long header is written to the user's destination at the beginning of the data and the last Information Exchange ENDDATA is written to the user's destination when the receive has ended.

Receiving only EDI data from your mailbox

To receive only EDI data from your mailbox, you can use an additional parameter, Receive EDI (**RM-RTYPE**) which, when set to Y (Yes) instructs Information Exchange to send to Expedite/CICS only data that has a CDH indicating it is EDI data.

Alternatively, if the person sending you data uses the Expedite/CICS default user classes, you can use the Information Exchange wild card receive feature to simplify receipt. For example, by specifying #E? as the user class in the receive request, you ask Information Exchange to return only files that have a user class beginning with #E. This includes all files sent with the default EDI user classes.



NOTE: The receive processing module expects each EDI envelope to be contained in a separate Information Exchange message group. If you receive a file that contains multiple EDI envelopes, the results are unreliable.

Receive processing flow

All Expedite/CICS receive processing is performed asynchronously as illustrated in Figure 11.

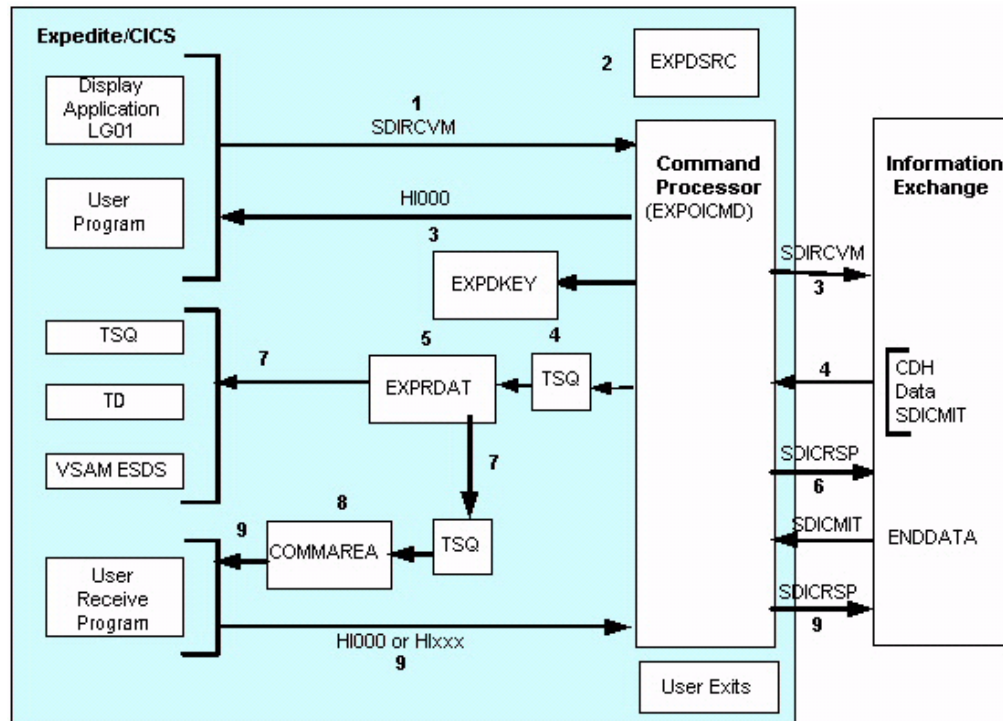

Figure 11. Expedite/CICS asynchronous receive processing

1. The receive request is issued from either of the following:
 - a. Expedite/CICS Display Application
 - b. User program
2. The display application or user program invokes the command processor, EXPOICMD. The command processor:
 - a. Identifies the command as a receive request
 - b. Writes a control record to the EXPDSRC VSAM file.

3. Expedite/CICS sends the Receive Message command, SDIRCVM, to Information Exchange.
4. Expedite/CICS returns HI000 to the program that issued the receive request, allowing the program to issue other commands while the data is received.
5. Information Exchange sends the first mail item satisfying the receive request criteria from the mailbox to Expedite/CICS, which writes the data to a TSQ. Information Exchange sends a commit at the end of the data. If you are using TCP/IP communication, Expedite/CICS validates the identity of Information Exchange by exchanging keys found in the EXPDKEY file.
6. Expedite/CICS reads the TSQ and writes the data to the receive data (EXPRDAT) VSAM file.
7. When Expedite/CICS has received the complete message into the EXPRDAT file, it sends a commit response to Information Exchange. Information Exchange then deletes the data from the mailbox. Expedite/CICS changes the receive file status from INCOMPLT to COMPLETE.
8. When the receive request specifies the destination to be:
 - a. A TSQ, TDQ or VSAM file, Expedite/CICS:
 - Reads the data from the EXPRDAT file.
 - Reblocks and writes the data to the file specified in the receive command.
 - Deletes the data from the EXPRDAT file.
 - b. A user application program, Expedite/CICS:
 - Reads the data from the EXPRDAT file.
 - Reblocks and writes the data to a TSQ.
 - Links to the user program specified in the receive command, passing it the TSQ named in the COMMAREA.
9. The user program:
 - Reads and processes data from the TSQ.
 - Deletes the TSQ and returns to Expedite/CICS.
10. If user program processing is successful, HI000 must be returned to Expedite/CICS. Expedite/CICS then deletes the message from the receive data (EXPRDAT) file and changes the receive file status from COMPLETE to RECEIVED.
11. If user program processing is unsuccessful, HIxxx (where xxx is not 000) should be returned to Expedite/CICS. The recommended return code in this case is HI050. If an error occurs during delivery to the receive destination or if a non-HI000 code is returned, then Expedite/ CICS:
 - Marks the receive file status in EXPDSRC in error.

- Writes an error message to the log destinations and to internal trace destinations if they are in use.
 - Retains the data in the EXPRDAT file until it is successfully released by the user and delivered, or deleted either by the user or by Expedite/CICS after the number of days specified in the Not-Sent Not-Received Retention parameter in the Define System Options panel.
12. Expedite/CICS can optionally link to the following user exit programs:
- User information monitor exit for information data collection, if the link to the user exit is enabled.
 - User completion notification exit for notification of receive exceptions, if it was specified in the Receive Message command; this is only invoked if an unrecoverable error occurs while Expedite/CICS is writing or returning data to the receive destination.
13. The receive of this message is now complete and the next mail item from the mailbox satisfying the receive criteria is processed. When there are no more items to process:
- For a single receive, the receive control record is marked RECEIVED and a receivecomplete message is sent to the user.
 - For a continuous receive, the receive request remains active, ready to receive any other items that arrive in the Information Exchange mailbox and which satisfy the receive criteria.

Receive error processing

The Expedite/CICS activity monitor plays an important role in ensuring that errors detected during receive processing are corrected so that data is successfully received, stored, and delivered to the user's receive destination.

If an error occurs while a receive request between Expedite/CICS and Information Exchange is in progress (status is NODATA or INCOMPLT) and before the message or file is written to the Expedite/CICS receive data (EXPRDAT) file, the activity monitor writes a message to the Expedite/CICS exception reporting and log destinations. A session reset or restart is invoked for the user and the receive is restarted again from Information Exchange. Information Exchange does not delete the data from the Information Exchange mailbox until it is successfully received and committed by Expedite/CICS. For more information, see Appendix A, "Understanding automated restart and recovery."

If an unrecoverable error occurs during delivery of the completed message or file to the user's destination (for example, the destination file is closed and the mail cannot be delivered), the receive control record is marked in error and an error message is written to the log destinations and to internal trace destinations if they are in use. The control record can be viewed as described in the Expedite/CICS Display Application User's Guide. The activity monitor ensures that, for data just-received from Information Exchange (status COMPLETE), an attempt is made to pass the data to the user's receive destination.

The file or message marked in error is held in the EXPRDAT file until purged or released by the user, or until it is automatically deleted by the activity monitor (as specified by the value of Not-Sent Not-Received Retention in the System Options panel). If the cause of the failures is corrected, the held mail can be released and delivered. More information on this procedure is provided in the Expedite/CICS Display Application User's Guide.

Managing data received from Information Exchange

When Information Exchange returns a message, the Expedite/CICS command processor sorts the data in the categories described below.

- **Administrative data:** Includes all system messages, excepting audit messages. The sending account is *SYSTEM*. This data is placed in the administrative response file, which defaults to TSQ EXPDRE1, if the default administrative response file was not changed. The administrative response file destination can be determined by using the Display Application to view user session options. For a list of *SYSTEM* user IDs, refer to the Expedite/CICS Display Application User's Guide.
- **Single receive:** Identifies command data by matching the first eight bytes of data received with the value placed into a single receive control record in the EXPDSRC file.
- **Continuous receive:** Identifies command data by matching the first eight bytes of data received with the value placed into a continuous receive control record in the EXPDSRC file.

The control records for in-process completed receives can be viewed using the Display Application. If you use the default response TSQ, EXPDRE1, the administrative data can be browsed, using CICS transaction CEBR.

Receiving messages from multiple trading partners

The command processor allows you to manage each data type separately. For example, you can:

- Selectively receive messages from your mailbox, using one or both of the following criteria:
 - User class, if the sender specifies a user class
 - Origin of an individual user or a list of users.
- To receive all EDI messages from your mailbox, issue a Receive Message command and specify Y in the RM-RTYPE field. Expedite/CICS determines which messages contain EDI data by looking at the EDI indicator in the CDH, which was created by the sender's interface product when the messages were sent.
- To receive only non-EDI messages from your mailbox, issue a Receive Message command and specify N in the RM-RTYPE field.
- To receive all messages from your mailbox, issue a Receive Message command, leaving the RM-DESTACCT, RM-DESTUID, and RM-MSGUCLS fields blank.



NOTE: When receiving all, be aware that you will also receive all system messages.

Issuing multiple receives: You can issue multiple continuous receives as needed. For example, if you have multiple trading partners and you want to process orders from each with a separate application, you can issue a continuous receive for each trading partner, specifying a different Account/Userid in the **RM-DESTACCT** and **RM-DESTUID** fields for each command. You may also issue multiple single receives, which are queued and processed one at a time.

If you have multiple trading partners from whom you receive time-critical messages, you should consider asking the trading partners to send the messages to multiple mailboxes, allowing you to have multiple continuous receives against multiple mailboxes, simultaneously, and to maximize the throughput, achieving multiprocessing. See “Maximizing system performance” on page 76 for more information.

Considering the receive destination:

Expedite/CICS supports the following receive destinations:

- TSQ
- TDQ
- VSAM (ESDS only)
- User program

You can use your application to manage these data categories. When you submit Receive commands to the command processor, you can instruct the command processor to:

Receive the data and write it to a file that you have defined to CICS. Set the value in the RM-FTYPE field to VS, TS, or TD, and the RM-FNM field to the name of the file.



NOTE: TDQs must be defined in the DCT as logically recoverable and VSAM files must be defined in the FCT. For extrapartition TDQs, there must be an entry in the CICS startup JCL.

- Call a receive application. To do this, set the value in the RM-FTYPE field to PG and the value in the RM-FNM field to the name of your receive application program.

The receive application program name must be defined in the processing program table (PPT).

If your application that processes the data supports one of the Expedite/CICS supported receive file destinations (VSAM ESDS, TSQ, or TDQ), you would specify the appropriate name in the Receive Message command. If this application does not accept data from a VSAM ESDS, TSQ, or TDQ, you must determine how you get the data into the appropriate file format, or to the receive application. You have three alternatives; in the Receive command, you can specify as your receive destination:

- A VSAM ESDS file, then run a VSAM REPRO job outside CICS to write the data; for example, to a flat sequential file.
- A TDQ, and define a trigger level, along with the CICS transaction ID that starts a program when the trigger level is reached and process the data from the TDQ.
- A user program that processes data as it is received from Information Exchange. This is implemented by specifying PG in the RM-FTYPE field and the program name in the RMFNM field. Event-driven processing occurs when this alternative is used for continuous receives. This is recommended for customers with time-critical application requirements. For more information, see “Invoking a receive program internal to CICS” below.

Invoking a receive program internal to CICS

Figure 12 shows how to invoke a receive application internal to CICS. User Program 1 asks Expedite/CICS to receive messages from the Information Exchange mailbox and link to User Program 2 to process the data. User Program 2 reads and processes the data from the TSQ, writes it to a DB2 database, and returns to Expedite/CICS.

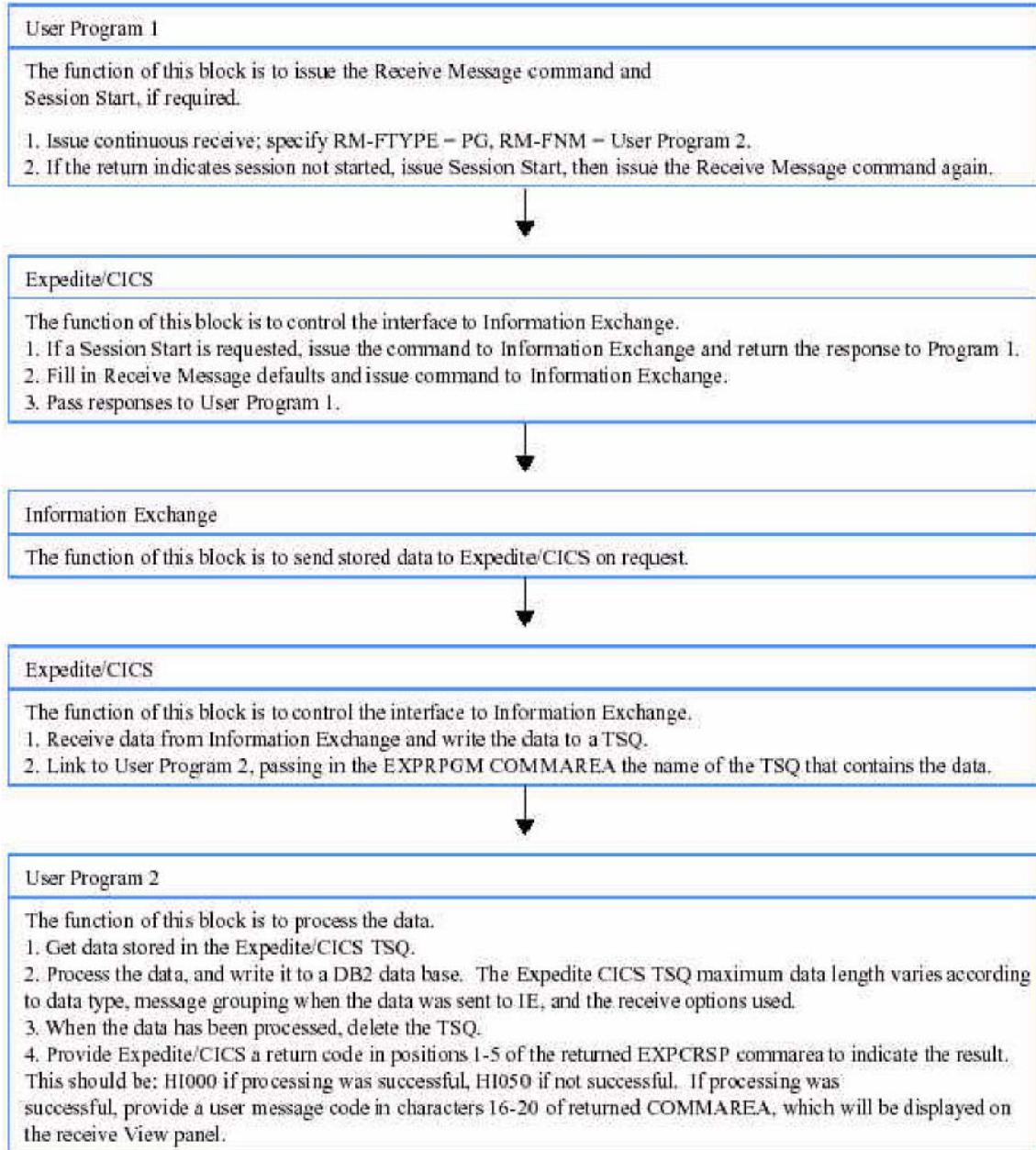

Figure 12. Sample application to receive batch data from Information Exchange

When the RM-FTYPE field of the Receive Message command specifies PG and the RM-FNAME field specifies a program name, Expedite/CICS links to your receive program, passing it a COMMAREA that names the TSQ that holds the data.

Your application is invoked by the Expedite/CICS receive process through an EXEC CICS LINK statement only after Expedite/CICS receives a complete message from Information Exchange. The command processor passes a formatted EXPRPGM COMMAREA that can range from 250 to 1500 bytes, depending on the number of TSQs required to hold the data. Your receive application should:

1. Define the EXPRPGM copybook in working storage and initialize it to spaces.
2. Inspect the EIBCALEN field for the exact length of the COMMAREA passed and then move that length to the standard layout.

Table 19. EXPRPGM receive application format

Column	Size	Name	Description
1	8	EXIFNAME	Your application program name
9	2	EXIFTYPE	PG-signifies program
11	8	EXISRC	TSQ(first 32767 data records)
19	8	EXICDH	TSQ (common data header)
27	4	EXIPAD	Padding
31	8	EXIACCT	Account name
39	8	EXIUSER	User ID
47	8	EXIUCLAS	User message class
55	1	EXIDTYPE	Data type
56	125	EXILNGHD	Information Exchange long header
181	8	EXISRC2	TSQ(second 32767 data records)
189	8	EXISRC3	TSQ(third 32767 data records)
197	8	EXISRC4	TSQ(fourth 32767 data records)
205	8	EXISRC5	TSQ(fifth 32767 data records)
213	8	EXISRC6	TSQ(sixth 32767 data records)
221	1500	EXISRCn	Additional temporary storage queue names

Received data is passed to your application in a TSQ. The 8-character name of the TSQ that contains this data is stored in EXISRC. If multiple TSQs are required to hold your data, EXISRC2, EXISRC3..., also stores the names of the TSQs that contain data.

Your application is invoked by the Expedite/CICS command processor once for every item of mail received from Information Exchange. When a receive request is issued, Information Exchange sends the items of mail that satisfy the receive criteria to Expedite/CICS one at a time. When an item has been received and committed within Expedite/CICS, the message is marked as COMPLETE. Then, Expedite/CICS passes the message to your receive program using the EXEC CICS LINK command. In the meantime, Information Exchange will start sending Expedite/CICS the next item of mail that satisfies the criteria. Your application will

also be invoked when a receive request has ended.

- For a single receive, this is when all items in the mailbox satisfying the receive criteria have been received.
- For continuous receive, this is when an end continuous receive has been explicitly requested.

When the receive ends, your application is invoked once. The COMMAREA passed to your program by Expedite/CICS contains the Information Exchange long header in the EXILNGHD field. An E in byte 39 of this long header indicates that this is an ENDDATA; that is, the receive has ended. The EXISRC TS queue will not contain any data unless the RM-CNTL field in the receive command was set to Y or F. In this case, the EXISRC field also will contain the Information Exchange ENDDATA header.

The EXICDH TSQ contains the common data header; because Expedite/CICS deletes this TSQ, it does not need to be deleted by your application upon return to Expedite/CICS. EXICDH stores the name of the TSQ that contains the data CDH. Copybook EXPCCDH can be used to process the CDH. For more information, see “Information Exchange Common Data Header (CDH)” on page 132.

The TSQs that contain data can contain several items, each of which either represents a logical data stream based upon data type processing performed by the command processor or is blocked at the maximum record length size specified in the receive command. The TSQ that stores the CDH contains only one item.

Your application must:

1. Read the TSQ(s).
2. Process the data. If your incoming message exceeds 32,767 records, the EXISRC2 through EXISRCn fields contain the names of the TSQs that hold the additional data. Process these TSQs in the order in which they appear in the COMMAREA.



NOTE: Because the TSQ named in the EXISRC field can contain several items, your application must read all items in the TSQ to ensure it processes all the data received. This is indicated by occurrence of an item error.

3. Delete the TSQ when finished. To ensure proper data sequence, each of these TSQs must be deleted before returning control to Expedite/CICS. The fields EXISRC2... EXISRCn will contain blanks when the entire message or file fits into one TSQ.
4. Return processing status to the command processor using the EXPCRSP COMMAREA shown in Table 20. Update the COMMAREA and issue an EXEC CICS RETURN statement.

Table 20 shows the EXPCRSP COMMAREA format that you must build into your program and return to Expedite/CICS.

Table 20. EXPCRSP COMMAREA format

Column	Size	Name	Description
1	5	RSPCODE	Specify HI000 if successful, or HI050 if not successful.
6	2	RSPSVCD	This field contains the message severity code
8	3	RSPFILL	This field contains zeros and is not used.

Column	Size	Name	Description
11	5	RSPTXTL	This field specifies the user message code length.
16	235	RSPTXT	This field contains a 5-character user message code when RSPCODE is not HI000.

Place a 5-byte response code in the RSPCODE field. A good response is indicated when this value is HI000 and 00 is placed in the RSPSVCD field. Any other values are interpreted as errors, and the command processor marks the data as being in error and does not delete the data from the receive data (EXPRDAT) file.

When processing is unsuccessful, you should provide your own message code in the RSPTXT field, bytes 16-235 of the returned COMMAREA, the first five bytes of which are displayed on the receive View panel to indicate what error occurred. This will occur only if the response code field, bytes 1-5, contains a non-HI000 code; that is, if user-receive processing was unsuccessful. HI050 is the recommended value for the response code.

If receive headers are requested on the Receive Message command, Expedite/CICS passes the first Information Exchange long header as the first item in the queue for both single and continuous receive requests. If more than one message is delivered, each TSQ containing a received message will always have the Information Exchange long header as the first item. When the receive request has ended, the ENDDATA header is passed to the receive program as the only item in the TSQ. The ENDDATA is received when no more messages match the receive criteria of a single receive request or, for continuous receive, when the request is stopped or the session ends. If no headers are requested, Expedite/CICS links to the receive program with empty TSQ EXISRC.

Issuing synchpoints from receive programs

You may issue sync points and rollbacks in your receive applications. Because Expedite/CICS is non-recoverable, the sync points and rollbacks do not affect the application.

When enqueues are released, Expedite/CICS checks an additional flag on the active receive control record for two minutes, before proceeding with the next message. For MVS, Expedite/CICS enqueues occur for the duration of the task, and sync point or sync point rollbacks in user receive applications do not affect them.

Invoking a receive program external to CICS

Expedite/CICS supports batch receive only through the Display Application, but you can process receive data using batch as described below. This provides an alternative for customers who use existing batch programs to process data external to CICS. Figure 13 explains how to invoke your receive program external to CICS. User Program 1 asks Expedite/CICS to place received data into a VSAM ESDS file and, when the receive is complete, close the VSAM file to CICS and submit a batch job to process the data.

Receiving data from Information Exchange

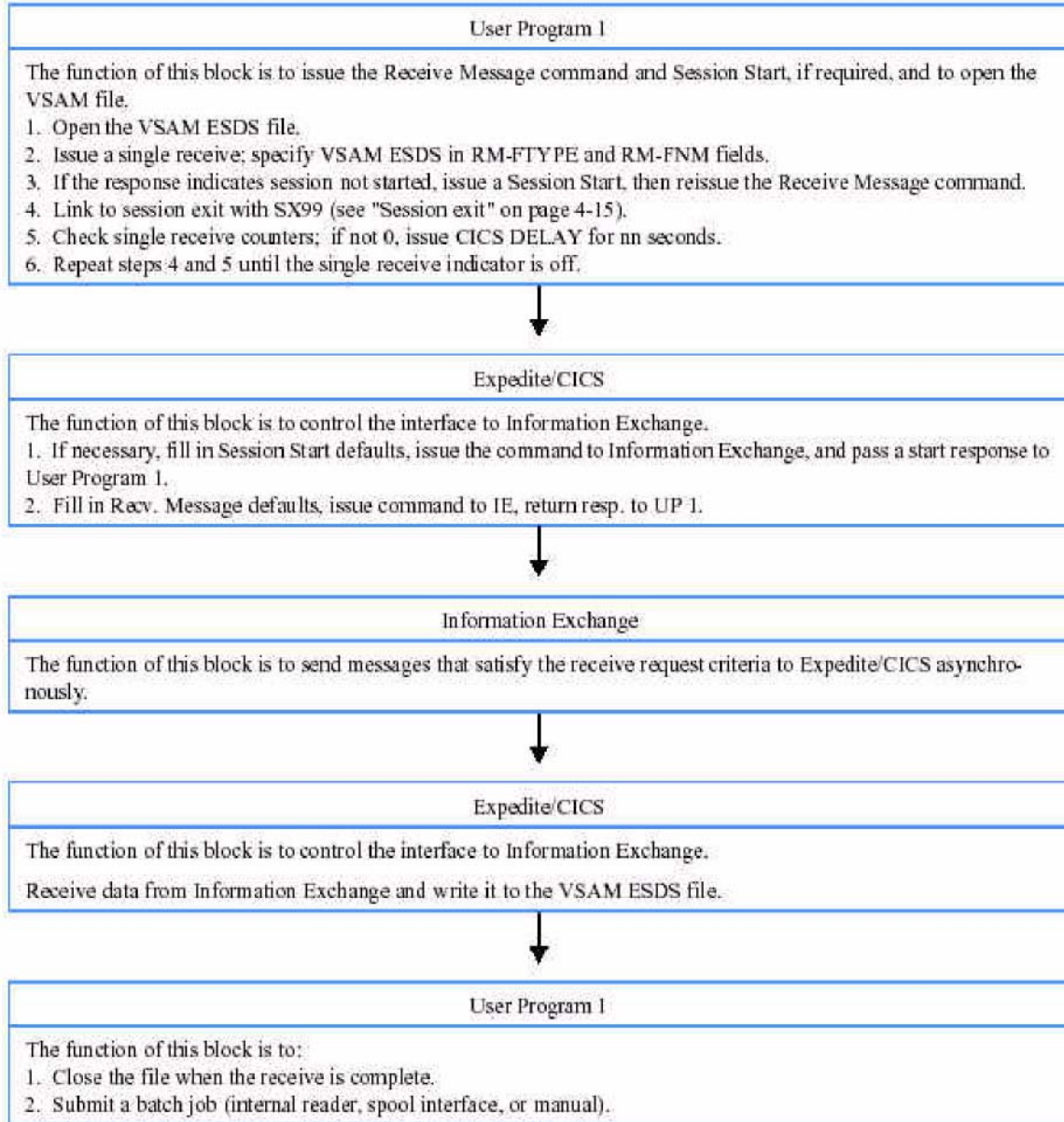

Figure 13. Processing data received from Information Exchange in batch



NOTE: For another alternative, see Chapter 5, “Processing batch data using Expedite/ CICS.”

Working with additional Expedite/CICS application features

Information Exchange and Expedite/CICS provide a number of useful features which, although not required, can enhance the usefulness and efficiency of your Expedite/CICS applications. This chapter explains how to use those features to the best advantage. The topics are presented as listed below:

- [Working with Information Exchange libraries](#) 126
- [Understanding acknowledgments](#) 127
- [Working with Expedite/CICS exit routines](#) 134
- [Information Exchange Common Data Header \(CDH\)](#) 143
- [Using audit trails](#) 150
- [Querying a mailbox](#) 157

Working with Information Exchange libraries

In Chapter 6, “Using Expedite/CICS commands in your application,” you will use a number of commands that apply to Information Exchange library tasks. If you have not worked with Information Exchange libraries, this topic gives you an introduction. The Expedite/CICS Display Application provides interactive panels to perform library commands or these library commands can be issued from a user program, using the commands described in Chapter 6, “Using Expedite/CICS commands in your application.”

A library is an Information Exchange facility that allows data to be stored for an extended period of time. Unlike messages in your mailbox, information in a library is not deleted automatically after a certain amount of time or after all recipients have received the information. Some examples of uses for libraries are:

- Product catalog information
- Technical specifications
- Problem descriptions
- Programs
- Newsletters
- Requests for quotes

Data is stored in a library in units called library members. For example, a product catalog library can consist of a separate member for each individual product.

When a library is defined, an owner for the library is designated. The owner is not necessarily the user who added the library and set up the library’s initial characteristics. A service administrator for the owner’s account or an alternate administrator for the owner can set up a library on the owner’s behalf. The characteristics of a library that are specified when the library is defined include:

- The name of the library
- The owning account ID
- The user ID of the library owner
- A description of the library
- Searchable or nonsearchable indicator
- Whether or not the library owner is willing to pay for viewing or retrieving library data
- Read and write authority to the library for other users

Read access allows users to view, search, and retrieve library member text. Write access allows them to enter or replace information. Users who have write access also have read access.

A library can be defined as either searchable or nonsearchable. In a searchable library, a keyword index is created. Each unique word and its document location are automatically entered in the index, which allows this type of library to be searched using keywords. Because the following library tasks can be time consuming, Information Exchange performs them asynchronously:

- Adding library members
- Deleting libraries
- Deleting library members

Table 21. Acknowledgement format

#	Column	Size	Field Name	Acknowledgement Description
5	16	125	MSGRESPN	Information Exchange command that caused this message to be issued SDISNDM For Putmember, Send File, and Send Message SDILRTV For Getmember
6	141	100	MSGDESCR	Message text generated by Information Exchange — varies with acknowledgment type to indicate whether a group was accepted, delivered, or purged for a user or list. The first eight characters contain the alphanumeric unique ID generated by an Expedite/CICS interface for acknowledgments. If this is not provided by an Expedite/ CICS interface, Information Exchange-generated values can range up to 16 characters.
3	8	3	CMDLNTH	Information Exchange command length
4	11	5	MSGDESLN	Length of Information Exchange message text

UNIQUEID assignment

A **UNIQUEID** value may be assigned by a user application and used with other field values (for example, message name and message sequence number, destination, and user class) of a Send File command to identify the message for Send Message completion and acknowledgment purposes. You can use values from the **MSGRESPN** (Send Message Header) and values from **MSGDESCR** (like the unique ID) to relate the acknowledgment to the message sent. Three methods that can be used to assign a **UNIQUEID** are described below.

1. Use the CDH format processed by Expedite/CICS and defined by copybook **EXPCCDH** to set **CDH-UNIQUEID** to a value greater than spaces, and then write the entire formatted area into a TSQ. Place the name of the TSQ into the Send File command field **SF-CCDH** before initiating the Send File process with Expedite/CICS. The value specified is used in all messages associated with the Send File command; for example, if multiple EDI envelopes exist in a file being sent.
2. Use the Send File command with a pass-through value of **4**, to set the **SF-UNIQUE** field in the command to a value greater than spaces. The value specified is used in all messages associated with the Send File command; for example, if multiple EDI envelopes exist in a file being sent.
3. If no user-supplied value is available (spaces exist in both interface fields), Expedite/CICS generates a unique value for each message in the associated file. You may use this Expedite/ CICS assigned value, which is an 8-character alphanumeric identifier. Files marked as EDI data, containing multiple EDI envelopes, are assigned unique values for each EDI message. The unique ID is stored as part of the Common Data Header in Information Exchange. The CDH can be viewed using Information Exchange Administration Services when the message is stored in the mailbox or in archive.

When an acknowledgment is received by Expedite/CICS and passed to a program or placed in the Response file, the acknowledgment is preceded by the Information Exchange Receive Message header, long format. The header length is 125 bytes, so the acknowledgment begins in byte 126. In other words, the acknowledgment is placed in the MSGTEXT portion of the Receive Message header, long format. For more information, see “Receive Message command” on page 237.



- If a value is supplied in the CDH, the value specified takes precedence and overrides any other value assigned.
- The UNIQUEID value in the first eight characters of the MSGDESCR field can be used to associate the acknowledgment with the message you sent.
- The UNIQUEID generated by Expedite/CICS and other related information can be returned to the calling application, using the send completion notification exit, as described in “Completion notification exit” on page 123.
- For more information, see:
 - “Specifying Information Exchange control fields” on page 94
 - “Sample acknowledgment program” below
 - the *Information Exchange Interface Programming Guide*

Sample acknowledgment program

The sample program, EXPRCVAK, is provided to help you process acknowledgments. EXPRCVAK can be invoked:

- As a CICS transaction
- By issuing a single or continuous-receive request for mail from *SYSTEM* *ERRMSG* using the Display Application and specifying the response destination with **File name** <EXPRCVAK> and **File management** <PG>.



NOTE: The transaction program PCT and PPT definitions need to be defined to your system.

If your installation processes Information Exchange acknowledgments, you might want to use EXPRCVAK:

- As a base, with a modified Process-Acknowledgments procedure
- As an example, for processing other command-processor commands

EXPRCVAK does the following:

1. If invocation is from a terminal, prompts for the account ID, user ID, and password, which identifies the user for whom acknowledgments are being requested.
2. Issues the EXPADMN command to change the user response destination to EXPRCVAK, PG so the program will be invoked when mail from *SYSTEM* *ERRMSG* arrives. (If the user does not have an active session, starts a session and reissues EXPADMN.)



NOTE: This action changes the response destination only for the active session. To change it permanently, the user profile must be revised.

Understanding acknowledgments

3. Issues a continuous receive from *SYSTEM* *ERRMSG*. When the continuous-receive request is issued:
 - a. Information Exchange invokes transaction ISC2 when mail from *SYSTEM* *ERRMSG* is placed in the mailbox.
 - b. Expedite/CICS receives the data and determines it is a system error message.
 - c. Expedite/CICS sends the data to the response file destination, EXPRCVAK.

When the sample program is invoked, Expedite/CICS passes EXPRCVAK a COMMAREA (layout provided in copybook EXPRCVAK), containing the name of the TSQ that has the acknowledgment data. EXPRCVAK processes the data by placing the information in the EXPL log destination. If data other than the three system acknowledgments is received, it is also placed in the EXPL destination.

Using acknowledgments with libraries

If you request an acknowledgment with a GETMEMBER command, three types of acknowledgments are available:

For type:	Information Exchange generates an acknowledge when:
Receipt	A member is placed in a receiver's mailbox.
Delivery	A member is successfully received from the receiver's mailbox
Purge	A member is deleted from the receiver's mailbox.

If a library owner pays the receive charges for the member, the library owner receives the acknowledgment; otherwise, the individual who issued the GETMEMBER request receives the acknowledgment.

If you request an acknowledgment with a PUTMEMBER command, two types of acknowledgments are available:

For type:	Information Exchange generates an acknowledge when:
Delivery	A member is placed in the library.
Purge	A member is deleted from the library.

The acknowledgment is always sent to the user ID that issued the PUTMEMBER command.



NOTE: The format of the acknowledgment when using libraries is the same as described in Table 21 on page 117.

Timing of Information Exchange delivery acknowledgments

Delivery acknowledgments are placed in a sender's mailbox when Expedite/CICS notifies Information Exchange that a message was successfully delivered to the Expedite/CICS Receive Data (EXPRDAT) file and Information Exchange marks the message as Received and removes it from the mailbox.



NOTE: If archiving was requested, Information Exchange also archives the message at this point.

Expedite/CICS then reads the message from the Receive Data (EXPRDAT) file, reblocks the data, and delivers it to the destination.

Expedite/CICS handles restart and recovery of a message in the process of being delivered to a destination, and does not delete it until it is successfully delivered, purged through the Display Application, or purged by Expedite/CICS after four months. For more information, see "Receive processing flow" on page 104.



NOTE: Other program interfaces may commit with Information Exchange at a different point, depending upon their processing. For example, when using Expedite Base/MVS, when session-level recovery is being used, Information Exchange will trigger acknowledgments only after the session has successfully ended.

Receiving Information Exchange acknowledgments

To process acknowledgments in a mailbox, use an Expedite/CICS receive command and specify address, *SYSTEM* *ERRMSG*. The acknowledgments are delivered to the response file name specified in your Expedite/CICS user profile. The response file destination defaults are:

File name < EXPDRE1 > File name
File management < TS > Temporary storage queue

You can receive acknowledgments into a TSQ, TDQ, VSAM file, or a program, subject to the following considerations:

- File management:

This code:	Specifies this kind of file management:
TS	Temporary storage queue
TD	Transient data queue
VS	VSAM (ESDS only) file
PG	The name of a user receive program

File name: Is the name of the file in which to store your acknowledgments, or the name of a user receive program to be called when you receive them.

The following rules apply:

If you receive acknowledgments into a TDQ or sequential VSAM file, you must create the file outside Expedite/CICS before it can be used.

For TDQ, you must define the TDQ in the destination control table (DCT) and, if an extrapartition TDQ, in your CICS startup JCL.

For TSQ, the temporary storage is defined dynamically by CICS.

For VSAM, you must define the file in the CICS file control table (FCT) and in your startup JCL, if the file name is not part of the FCT definition.

If you specify a program name, the program must be able to process the receive data and COMMAREA passed and must be able to return a proper response. The program name must be defined in the processing program table (PPT). For more information, see “Sample acknowledgment program” on page 119.

For more information about creating transient data queue and VSAM entry sequenced data set (ESDS) files, see your service administrator or CICS systems programmer.



NOTE: The destination response file can be altered for the duration of a session using the Set response destination option of the User Session Selection Menu, or by using the EXPADMN program interface command. During the next session start, the response destination is reset to the value in the user session profile. The acknowledgment is delivered with the Expedite/CICS receive message header prefixed to the acknowledgment.

Expedite/CICS completion-notification acknowledgments

The Expedite/CICS program interface provides the capability to start or link to a program to process completion notification of send and receive requests. The program invoked is a userwritten program that receives completion notification from Expedite/CICS and processes it accordingly.

- A send completion-notification program can be invoked for each send request, with notification of successful and unsuccessful responses returned. The completion notification indicates whether a message was or was not sent to Information Exchange.
- A receive completion-notification program can be invoked on an exception basis when an unsuccessful response is returned. The completion notification indicates an error occurred, and the message was not delivered to the user-specified destination by Expedite/CICS; for example, the receive file was closed. The receive completion notification of exceptions monitors the delivery status between the Expedite/CICS receive data file and the specified destination.

For more information, see “Completion notification exit” on page 123.

Application acknowledgments

Beginning and ending application programs can send and receive acknowledgments to each other through Information Exchange to ensure that beginning and ending processes have completed processing. This is most useful because sending and receiving applications connected to Information Exchange and Expedite/CICS perform additional processing.

The format of these acknowledgments is a matter of preference. The EDI translator will generate functional transaction acknowledgments based on the EDI standard. For example, DataInterchange generates 997 (X12), 999 (UCS), or CONTRL (EDIFACT) EDI

acknowledgments if requested. A systems analyst should determine the best solution regarding how and when to process acknowledgments, based upon your system and environment. Information Exchange treats these acknowledgments the same as any other message.

Working with Expedite/CICS exit routines

This section provides information about the Expedite/CICS information collection and data management exit routines. The major topics are listed below:

- “Working with information collection exits” below
 - “Standard user exit program layout” on page 124
 - “Completion notification exit” below
 - “Information monitor exit” on page 124
- “Working with data management exits” on page 127
 - “Session Exit” on page 128
 - “Security Exit” on page 130

Working with information collection exits

Expedite/CICS provides the information collection exits listed below for Send and Receive requests, each of which uses the Expedite/CICS standard data layout provided in “Standard user exit program layout”. The exits are invoked as the final processing of a message. These exits cannot be used for Expedite/CICS batch-driven Send or Receive requests.

- The completion notification exit is invoked for a specific Send File request when it completes or for a Receive request when the message completes with an exception. These exits are identified using the **SF-UPROG** field in the initiating Send File command or the **RM-EXCEPTS** field in the initiating Receive command.
- The information monitor exit is invoked system-wide for asynchronous Send requests and all Receive requests.

Completion notification exit

Use the completion notification exit to track messaging outcome from specific Send and Receive requests initiated from an application interacting with Expedite/CICS. This exit provides this information for both Send and Receive commands issued with the appropriate control fields; see Send File command fields **SF-UPROG** and **SF-UPROGTYP**, and Receive request field, **RMEXCEPTS**.

As a result of an initiating Send command, Expedite/CICS invokes the user exit as a linked-toprogram or a started transaction, depending on how the Send command control fields are set. The exit is passed message and task information, using the standard layout described in Table 22 on page 124, through the **COMMAREA** for linked-to-programs or through the **From** parameter for a started transaction.

The exit is invoked by a Send request in either the synchronous or asynchronous execution modes after the current message data is sent to Information Exchange. The linked-to-program or started transaction must be correctly defined to CICS. When EDI data is involved in a Send request, the exit is accessed once per EDI header found in the data. The standard layout contains data from the current EDI header. The **UX-UNIQUE** data element in the layout contains the same value placed into the **CDH** for this message on the send, which in turn shows up in related acknowledgments. For information on assigning a **UNIQUEID**, see “**UNIQUEID** assignment” on page 118.

As a result of an initiating Receive command, Expedite/CICS invokes the user exit as a linkedtoprogram based on a value other than spaces in the Receive Message (RMEXCEPTS) command. The exit is passed the standard layout through the COMMAREA containing message and CICS task information. This takes place after an attempt to deliver the current message data to the receive destination has taken place and an exception has been detected. The linked-toprogram must be correctly defined to CICS. When EDI data is involved in the receive request, the standard layout contains data from the current EDI header.



NOTE: Completion notification exits monitor processing between Expedite/CICS and Information Exchange on the send, and Expedite/CICS and the receive destination on the receive. Completion notification is invoked immediately after processing to send data to Information Exchange, or to receive data into the destination. Abend errors that occur during other processing of send or receive requests may not be returned via completion notification, but will be written to the log destinations in the internal trace.

Information monitor exit

Use the information monitor exit to track messaging outcome from all asynchronous send requests and all receives taking place in Expedite/CICS. The exit is activated by providing the name of a program and setting the value of **User info exit** active on the Define System Options panel to Y. When this is done, this exit is invoked at the end of send or receive message processing, whether or not the message is successfully processed. The exit is passed message and task information, using the standard layout described in Table 22 on page 124, through the COMMAREA in a link to the identified program. The program to be linked must be correctly defined to CICS.



NOTE: If using DataInterchange, the information user exit can also be invoked by the DataInterchange translator.

Standard user exit program layout

Table 22 describes the standard user exit layout.

Table 22. Standard user exit layout

Column	Size	Field Name	Field Description
1	5	UX-RESP	Indicates the completion code for send or receive requests, HI000 or HIxxx. HI000 indicates successful completion; any other value indicates an error. Additional information is provided in the EXPM destination (EXALERT).

Table 22. Standard user exit layout

Column	Size	Field Name	Field Description														
6	8	UX-TYPE	Identifies the type of user exit. The valid values are: <table border="0"> <tr> <td>This value:</td> <td>Indicates:</td> </tr> <tr> <td>SENDERR</td> <td>The Expedite/CICS send function detected an error</td> </tr> <tr> <td>RCVERR</td> <td>The Expedite/CICS receive function detected an error</td> </tr> <tr> <td>ENVELOP</td> <td>A DI/CICS enveloping exit</td> </tr> <tr> <td>DENVELOP</td> <td>A DI/CICS de-enveloping exit</td> </tr> <tr> <td>SENT</td> <td>Expedite/CICS sent data to Information Exchange</td> </tr> <tr> <td>RECEIVED</td> <td>Expedite/CICS received data from Information Exchange</td> </tr> </table>	This value:	Indicates:	SENDERR	The Expedite/CICS send function detected an error	RCVERR	The Expedite/CICS receive function detected an error	ENVELOP	A DI/CICS enveloping exit	DENVELOP	A DI/CICS de-enveloping exit	SENT	Expedite/CICS sent data to Information Exchange	RECEIVED	Expedite/CICS received data from Information Exchange
This value:	Indicates:																
SENDERR	The Expedite/CICS send function detected an error																
RCVERR	The Expedite/CICS receive function detected an error																
ENVELOP	A DI/CICS enveloping exit																
DENVELOP	A DI/CICS de-enveloping exit																
SENT	Expedite/CICS sent data to Information Exchange																
RECEIVED	Expedite/CICS received data from Information Exchange																
14	1	UX-DIRECTION	Indicates whether the message is being Sent (S) or Received (R).														
15	4	UX-EDISQUAL	Indicates the sender's EDI qualifier from the EDI header. Refer to the common data header for a description of this field.														
19	35	UX-EDISENDR	Indicates the sender's EDI ID from the EDI header. Refer to the common data header for a description of this field.														
54	4	UX-EDIRQUAL	Indicates the receiver's EDI qualifier from the EDI header. Refer to the common data header for a description of this field.														
58	35	UX-EDIRECVR	Indicates the receiver's EDI ID from the EDI header. Refer to the common data header for a description of this field.														
93	14	UX-EDICNTLN	Indicates the EDI interchange control number from the header.														
107	8	UX-CACCT	Indicates the sender's Information Exchange account name. This user-defined field, along with the UX-CUSER field, identifies the sender. Format: alphanumeric, left-justified, padded on the right with blanks.														
115	8	UX-CUSER	Indicates the sender's Information Exchange user ID. This user-defined field, along with the UX-CACCT field, identifies the sender. Format: alphanumeric, left-justified, padded on the right with blanks.														
123	1	UX-CLTYP	Indicates the receiver's alias table type (G , I , O , or P). This field is used only when UX-CDTYPE is D ; in which case it is used together with UX-CLID , UX-CDACCT , and UX-CDUSER to identify the alias entry or inter-system ID to which data is to be sent.														

Column	Size	Field Name	Field Description
124	3	UX-CLID	Indicates the receiver's alias table ID. The value is userdefined or blank. It is used only when UX-CDTYPE is D ; in which case it is used together with UX-CLTYP , UXCDACCT , and UX-CDUSER to identify the alias entry or intersystem ID to which data is to be sent.
127	8	UX-CDACCT	Indicates the receiver's Information Exchange account ID. The value is user-defined or blank. If not blank, the field can contain one of the following: <ul style="list-style-type: none"> • A destination account name, or the first eight characters of an alias name if UX-DCTYPE is D • A list name, if UX-DCTYPE is L Format: alphanumeric, left-justified, padded on the right with blanks
135	8	UX-CDUSER	Indicates the receiver's Information Exchange user ID. The value is user-defined or blank. The value may be one of the following: <ul style="list-style-type: none"> • The destination user ID, or the last eight characters of an alias name, if UX-DCTYPE is D • Blanks, if UX-DCTYPE is L. Format: alphanumeric, left-justified, padded on the right with blanks.
143	1	UX-CDTYPE	Indicates the type of source name in the UX-CDACCT and UX-CDUSER fields. The value may be one of the following: <p>This value: Indicates:</p> <p>D UX-CDACCT and UX-CDUSER fields identify a single source destination.</p> <p>L UX-CDACCT contains a destination list name and UX-CDUSER is blank.</p>
144	8	UX-MSGUCLS	Indicates the user message class. This field is userdefined.
152	8	UX-UNIQUE	Indicates a unique identifier for a send request; the identifier is part of the CDH and is assigned during send processing.
160	8	UX-DATE	Indicates the CICS date in YYYYMMDD format.
168	6	UX_TIME	Indicates the CICS date in HHMMSS format.
174	8	UX-APPLID	Indicates the application ID.
182	4	UX-TRANS	Indicates the transaction ID.
186	7	UX-TASK	Indicates the CICS task number

Column	Size	Field Name	Field Description
193	11	UX-DENVSIZE	Indicates the size of the data envelope. Expedite/CICS sets this field to zeros and makes it available for use by other applications; for example, DataInterchange.
204	11	UX-DNEDITRN	Indicates the number of EDI transactions within the message envelope. Expedite/CICS does not inspect the EDI envelope for such information but sets the field to zeros and makes it available for use by other applications.
215	11	UX-DIESIZE	Indicates the total size, including Information Exchange headers, of an EDI message. Expedite/CICS supplies this value after the file has been sent or received.
226	14	UX-APPREF	Indicates the assigned DataInterchange application reference.
240	14	UX-USER-AREA	See SF-USER-AREA of the “Send File command COMMAREA format” on page 257
290	8	UX-CONTROL	Indicates the type of control for a Send or Receive request. The value in this field consists of eight bytes, the first of which may be one of the following: E Indicates a send request error or receive request. S Indicates a single receive request or send request. C Indicates a continuous receive request. The remaining seven characters provide a unique numeric ID.
298	203	UX-FILLER	This field is reserved.

User exit program processing

Programs identified to Expedite/CICS for either the completion notification exit or the information monitor exit should be able to handle any errors within their own processing code. If a program does not provide an abnormal-end routine, control is automatically returned to Expedite/CICS, which will write a message to the log destinations and internal trace destinations stating that the exit program failed. The cause of the abend will be lost. For this reason, it is recommended that exit programs contain program interrupt logic to report program checks before returning to Expedite/CICS. In either case, Expedite/CICS will then resume normal processing.

A sample program, EXPOUEXT, is provided with a descriptive remarks section that can be a starting point for a more comprehensive program.

Working with data management exits

Expedite/CICS data management exits may be used to check indicators and help you manage sessions. Each exit supports a COMMAREA of 500 bytes. There are two types of exits for managing Information Exchange sessions.

- Session Exit: Creates and maintains a user session record and the user default records.
- Security Exit: Verifies the identity of a user who wants to continue an active Information Exchange session that the user has left temporarily. This prevents other users from entering active Information Exchange sessions.

Session Exit

Your application can call the Session Exit by passing a COMMAREA that specifies the status of a user session and what processing is to be performed. Invoke the Session Exit with the following command:

```
EXEC CICS LINK PROGRAM (EXPOSES1) COMMAREA (xxxxxx) LENGTH (500) END-EXEC
```

Table 23 describes the information you must pass (in COMMAREA) to the Session Exit routine.

Table 23. Session exit COMMAREA input

Column	Size	Field Name	Field Description
1	8	SESACCT	Specifies the account ID of the session profile record for the user who is passing parameters to the Session Exit.
9	8	SESUSER	Specifies the user ID of the session profile record for the user who is passing parameters to the Session Exit
17	8	SESCMD	Specifies the task the Session Exit routine should perform. This function: Retrieves this information: EXPOSES5 Time-zone indicator (from the system default session profile). EXPOSX10 Value for the size of the message grouping. EXPOSX99 A copy of the user's entire session profile record. Returns all indicators within the COMMAREA.
25	226	SESPAD	Contains blanks.

Session Exit responses: The Session Exit routine returns information to your application in the same response format returned from the command processor when it is called by your application. The response is 500 bytes long and is passed to the calling program in the COMMAREA.

Table 24 describes the format returned if response HI001 is returned in the RSPNO field. In addition to HI001 in the RSPCODE field, the following responses are received in the RSPDATA field:

For SESCMD:	The response text indicates:
EXPOSES5	First five bytes contain the time-zone indicator (character 5)
EXPOSX10	First five bytes contain the default group-size value (character 5)
EXPOSX99	The strings indicated in Table 24

Table 24. Session exit response format

Size	Description
8	Session Access Key
3	Operator ID
	 NOTE: The next six indicators are counters used to indicate how many send and receive requests are incomplete. A value of zero means all are complete.
2	Single Receive counter(fixed binary 15)
2	Continuous Receive counter (fixed binary 15)
2	End Continuous Receive counter (fixed binary 15)
2	Session End counter (fixed binary 15)
2	Send Message counter (fixed binary 15)
2	Message Package counter (fixed binary 15)
2	Total message length sent to Information Exchange
2	Administrative response file name
2	Administrative response file type
8	Single Receive source account
8	Single Receive source user ID
8	Single Receive source list
8	Single Receive user message class
8	Single Receive reference name
8	Single Receive stored message name
8	Single Receive immediate delivery name
8	Single Receive error message name
8	Single Receive file name
2	Single Receive file type
1	Single Receive data type
1	Single Receive X12 data delimiter
8	Continuous Receive source account
8	Continuous Receive source user ID
8	Continuous Receive source list
8	Continuous Receive source list
8	Continuous Receive name reference
8	Continuous Receive stored message name
8	Continuous Receive immediate delivery name
8	Continuous Receive error message name
8	Continuous Receive file name
2	Continuous Receive file type

Size	Description
1	Continuous Receive data type
1	Continuous Receive X12 data delimiter
8	Send File account name
8	Send File user ID name
8	Send File list name
8	Send File user message class
8	Send File name
2	Send File (file) type
1	Send File data type
1	Send File acknowledgement

If an error occurs during Session Exit routine processing, the response HIXXX COMMAREA format is returned. See Table 10 on page 66 for the layout of this response format. See Expedite/ CICS Messages for a list of Expedite/CICS error messages and for problem solving information.



NOTE:

- Values in the Single Receive, Continuous Receive, and Send File fields apply to the last request of that kind issued by the user.
- An example of a session exit implementation is provided in “Invoking a receive program internal to CICS” on page 109

Security Exit

When a user attempts to log on, the Expedite/CICS Display Application Security Exit captures and stores the CICS OPID value in the user’s session profile. It is optional for your application to use the Security Exit to verify user identity. If you are going to use the same account ID and user ID from both your application and the Expedite/CICS Display Application, you must do one of the following:

- Write a replacement Security Exit interface (EXPOSCX1) to always return response HI000 to the COMMAREA.
- Always log off from your application before you log on to the Expedite/CICS Display Application. Otherwise, you receive error message HI205 when logging on the Expedite/ CICS Display Application.

Invoke the Security Exit with the following command:

```
EXEC CICS LINK PROGRAM(EXPOSCX1) COMMAREA(XXXXXXXX) LENGTH(500) END-EXEC
```

The table below describes the information that must be passed (in COMMAREA) to the Security Exit routine when a user attempts to return to an Information Exchange session:

Table 25. Security exit COMMAREA input

Column	Size	Field Name	Field Description
1	8	SECACCT	Account ID to be validated
9	8	SECUSER	User ID to be validated
17	234	SECPAD	Padding

Security Exit responses : After the Security Exit receives the information, it returns one of the following return codes to RSPCODE in the COMMAREA. It could be an error message.

This code:	Means the data your application sent:
HI000	Was validated and processed
HIxxx	Contains an error. See <i>Expedite/CICS Messages</i> for a list of Expedite/ CICS error messages and for problem-solving information.

The response COMMAREA is formatted to match the error messages. See “Command processor responses” on page 63 for the response COMMAREA formats.

Information Exchange Common Data Header (CDH)

Information Exchange interfaces can use a Common Data Header (CDH) to communicate detailed information about files and messages to other interfaces. Expedite/CICS builds a CDH for every message and file that is sent and recognizes CDHs received from other interfaces.

The CDH provides details, such as file name and carriage-return and line-feed options, which enable a receiving interface to reconstruct the original format of a received message. It also makes more information available to the recipient of a message or message group.

The actual location and format of the CDH is transparent to the Information Exchange user. However, when looking at a trace of an Information Exchange message flow, you might notice an additional message at the beginning of each Information Exchange message group. This extra message contains the CDH.

A CDH is created for every message and file sent from Expedite/CICS. When sending EDI data, a header must be created for every Information Exchange message group produced as a result of the Send EDI command. Whenever possible, Expedite/CICS supplies default values for all unspecified fields of a CDH.

Expedite/CICS issues a request for a CDH with all Receive commands. You can also issue a request in your receive application for Expedite/CICS to use the CDH fields to determine the receive processing for the received data. In this case, the CDH fields used are: data format, record delimiter, record length, and record format. For more information, see Chapter 3, “Developing an Expedite/CICS application.”

Expedite/CICS provides copybook EXPCCDH for use by send applications to set the CDH fields. To provide a user-supplied CDH, the Send File command passed to the command processor must contain a TSQ name in the SF-CCDH field. This TSQ must contain the CDH information, the layout of which is described in Table 26 on page 132. If no user-supplied CDH is provided, Expedite/CICS generates a CDH using the fields from the Send File command and its own default values.

Expedite/CICS also passes the CDH for a Received file to receive applications in the TSQ specified in the EXICDH field of the EXPRPGM COMMAREA to the user receive program.

Table 26 describes the CDH format.

Table 26. CDH format

Column	Size	Field Name	Field Contents
1	44	CDH-FILENAME	The name of the data set on the sending system
45	65	CDH-LOCATION	The location of the file on the originating system; this is a system-dependent field. In Expedite/CICS, it contains items such as the TSQ name.
110	4	CDH-RECORDF	The record format of the file on the sending system; this field is used primarily for documentation. The record format across systems is handled by the record delimiter field. If the record format is not four bytes long, this field is left-justified and filled with blanks.
114	8	CDH-TTYPE	The name of the translate table Expedite/CICS will use for translating data sent and received. Expedite/ CICS does not use this field for processing data.
122	79	CDH-DESCRIBE	A free-format description of the message, used primarily for documentation purposes.
201	8	CDH-UNIQUEID	An ID assigned by Expedite/CICS to identify each message, used primarily for documentation purposes. The unique ID is returned to the sending user when the message is successfully stored in Information Exchange. For more information about how CDH-UNIQUEID can be used, see “Understanding acknowledgments” on page 117.
209	3	CDH-CODEPAGE	The character representation of symbols such as \$ and #, which mean different things in different countries. This code page information is for documentation only. Expedite/CICS allows you to enter a code page and forwards it, but does not use it to process data.
212	6	CDH-FILEDATE	The date (in YYMMDD format) the file was last modified on the sending system. It is used primarily for documentation purposes.
218	6	CDH-FILETIME	The time (in HHMMSS format) the file was last modified on FILETIME the sending system. It is used primarily for documentation purposes.

Table 26. CDH format

Column	Size	Field Name	Field Contents
224	3	CDH-CTRLFEOF	<p>The translated character values for CR, LF, and EOF that an EBCDIC device uses when processing record delimiters for received data. This field is built by any ASCII device, such as a PC, when sending translated data. The translation table used determines the characters used for the CRLF record delimiters and the EOF character.</p> <ul style="list-style-type: none"> • For Information Exchange translation, the ASCII CRLF translates to x'0D0A', and the EOF to x'1A'. • For 3270 translation, the ASCII CRLF translates to x'0D25' and the EOF to x'3F'. <p>Interfaces must be able to handle the different types of record delimiters based on the translation table.</p>
227	2	CDH-RLENGTH	<p>The record length of the file on the sending system; this field is used primarily for documentation. The record length across systems is handled by the record delimiter field. The type of data contained in the message, as described below</p>
229	1	CDH-CTYPE	<p>This code: Indicates this type of data:</p> <p>x'01' EBCDIC (character data readable by an end user)</p> <p>x'02' Binary (other data such as executable code or graphics data stream)</p> <p>For non-PC devices, this field is primarily for documentation. For PC devices, the field controls data translation. Because a PC is an ASCII device, it must translate non-binary data to EBCDIC before it sends the data to Information Exchange and must translate received non-binary data to ASCII. This translation was previously done for all PC data. This field allows the PC to do translation on only appropriate (EBCDIC) data.</p>

Table 26. CDH format

Column	Size	Field Name	Field Contents
230	1	CDH-DELIMIT	<p>Record delimiters provided by the sending interface</p> <p>This code: Indicates records are:</p> <p>x'01' Delimited with CRLF characters</p> <p>x'02' with two-byte length (LL)</p> <p>x'03' EDI delimited (always set for EDI data)</p> <p>x'04' Not delimited (Default for OTHER data)</p> <p>When data is sent through Information Exchange, its record format is lost. Record delimiters, provided by the sending interface, permit a receiving interface to reconstruct the record format of the received data. There are two methods used to delimit records.</p> <ul style="list-style-type: none"> • Terminate each record with CRLF characters (often used by PC interfaces) • Precede each record with a two-byte binary length <p>The sending interface is responsible for storing the method used to delimit records in the record delimiter field of the header. The receiving interface can then use this field to reconstruct the records without having to know the method used to delimit the records.</p> <p> NOTE: EDI data does not use the record delimiters described here. EDI records are always delimited by EDI standard delimiters.</p>
231	1	CDH-DFORMAT	<p>This code: Indicates records are:</p> <p>x'01' X12</p> <p>x'02' UCS</p> <p>x'03' EDIFACT</p> <p>x'04' UN/TDI</p> <p>x'05' Not EDI (Default)</p> <p>Expedite/CICS sets this field by examining the data in the Send EDI command. If a Send EDI is not being done, Expedite/CICS marks the data as not EDI. A receiving interface can use this field to place the received EDI data in the proper record format.</p>

Table 26. CDH format

Column	Size	Field Name	Field Contents
232	1	CDH-SYSTYPE	<p>The type of system sending the data.</p> <p>This code:</p> <p>x'01'</p> <p>x'10'</p> <p>x'11'</p> <p>x'12'</p> <p>x'14'</p> <p>x'15'</p> <p>x'16'</p> <p>x'17'</p> <p>x'20'</p> <p>x'21'</p> <p>x'30'</p> <p>x'01'</p> <p>x'33'</p> <p>x'40'</p> <p>x'44'</p> <p>x'80'</p> <p>x'90'</p> <p>Indicates the system is:</p> <p>Unknown system type</p> <p>Expedite/PC</p> <p>Expedite Base/2</p> <p>Expedite Base/AIX</p> <p>Base for SCO UNIX</p> <p>Expedite Base/DOS</p> <p>Expedite Base for SCO XENIX</p> <p>Expedite Base for Windows</p> <p>Expedite/MVS Host</p> <p>Expedite Base/MVS</p> <p>Mail Exchange</p> <p>Expedite Base/VM</p> <p>X.400 Gateway</p> <p>Expedite/Direct</p> <p>EDI VAN Interconnect</p> <p>Expedite/CICS</p> <p>Information Exchange Administration Services</p> <p>This field allows a receiving interface to process received data differently based on the sending system type. For example, a receiving PC interface may ensure that the received file name matches the file name on the sending system if the sending system was a PC.</p>
223	1	CDH-VERSION	<p>The software version of the system sending the data; this value relates to the sending system data type (CDH-CTYPE) field. Expedite/CICS inserts the current version number in this field.</p>
234	4	CDH-EDISQUAL	<p>This field contains the ID qualifier of the EDI sender. For X12 data, this field contains a 2-byte qualifier. For EDIFACT data, it contains a 4-byte qualifier. This field contains the entire qualifier, including trailing blanks. This field is not used for UCS and UN/TDI data, because they do not have an ID qualifier.</p>
238	35	CDH-EDISENDR	<p>This field contains the ID of the EDI sender. It contains the entire ID including trailing blanks.</p>
273	4	CDH-EDIRQUAL	<p>This field contains the ID qualifier of the EDI receiver. For X12 data, this field contains a 2-byte qualifier. For EDIFACT data it contains a 4-byte qualifier. This field contains the entire qualifier, including trailing blanks. This field is not used for UCS and UN/TDI data, because they do not have an ID qualifier.</p>

Table 26. CDH format

Column	Size	Field Name	Field Contents
277	35	CDH-EDIRECVR	This field contains the ID of the EDI receiver. It contains the entire ID including trailing blanks.
312	14	CDH-EDICNTLN	This field contains the interchange control number for EDI data.
326	8	CDH-LIBACCT	This field contains the owning account of the library that contains the data.
334	8	CDH-LIBNAME	This field contains the name of the library that contains the data. You must supply this field when you reference a library. If you supply CDHLIBNAME, you must also supply CDHLIBMEMB
342	8	CDH-LIBMEMB	This field contains the name of the library member that contains the data. You must supply this field when you want to reference a library. If you supply CDH-LIBMEMB, you must also supply CDHLIBNAME.
350	1	CDH-LIBREPL	This field states whether the library member should be replaced. If you do not specify CDH-LIBREPL and the member exists, Information Exchange generates an error. A value of Y tells the system to replace the member. A blank or a value of any character other than Y tells the system not to replace the member. This is the default.
351	30	CDH-PADCHAR	
381	4	CDH-ORGLLEN	This field contains the original length of the data before the addition of any record delimiters (on an MVS system). A value of zero indicates the length is unknown.
385	30	CDH-PADNUMS	
415	10	CDH-COMPSOFT	This field indicates the software used to compress the data
425	5	CDH-COMPSVER	This field indicates the version of the software used to compress the data.
430	10	CDH-COMPDLEN	This field indicates the length of the data after compression. This field is an EBCDIC numeric character representation. For example, X'F1F2' represents a length of 12.

Table 26. CDH format

Column	Size	Field Name	Field Contents
440	44	CDH- COMFNAME	This field indicates the name of the file where the compressed data has been stored.

Using audit trails

Information Exchange provides an audit trail that you can retrieve using Expedite/CICS or view using Information Exchange Administration Services. For information on viewing audit data, see the Information Exchange Administration Services User's Guide. Audit trails are files that contain information about files you send and receive. Audit trails can include the following information:

- Name of the file sent or received
- Account and user ID of the person who received the file
- Account and user ID of the person who sent the file
- Date and time the file was sent or received
- User class of the file
- Current status of the file (for example; in mailbox, delivered at x date and y time, and so on)

The command processor will process requests for Level-1 or Level-2 audit trails. Level-1 audit trails contain basic information about your files. There is no charge for requesting Level-1 audit trails. Level-2 audit trails contain more detailed information about your files and have a charge (per character) associated with them. Contact your marketing representative for more information about Level-2 audit trails. For information on other extension levels, refer to the *Information Exchange Interface Programming Guide*.

You can use the information in audit trails to see the status or final disposition of a file. For example, if you send an order electronically to a manufacturer on July 1st and do not receive the items as expected, you can request an audit trail of the files you sent to that manufacturer on July 1st. The audit trail may show that the manufacturer never received the order and it is still in their mailbox. If the audit trail shows that they received the order, you may want to check with the manufacturer to find out if the order was ever processed.

You can also use audit trails to see how many files you sent or received over a specific time period. For example, you can request an audit trail that shows all of the files you sent over the last three weeks.

Retrieving audit trails

Use the Audit Retrieve command to retrieve an audit trail from Information Exchange and place the information in your mailbox. When audit data is available, use the Receive Message command to retrieve it. The source account the file comes from is *SYSTEM*, the user ID is *AUDITS*, and the user class is #SAUDIT. Information Exchange does not prepare a Common Data Header (CDH) to accompany retrieved audit records.

Audits may not be available immediately after the Audit Retrieve command has been issued. For more information on the Audit Retrieve and Receive Message commands, See "Audit Retrieve command" on page 171 and "Receive Message command" on page 237.

Within Expedite/CICS, there are two ways to issue an audit retrieve:

- Issue an audit retrieve from the Display Application (this requests only Level-1 records).
- Use an Audit Retrieve command from a user program as described in See "Audit Retrieve command" on page 171. This can request either Level-1 or Level-2 records.
- Enter the audit retrieve command as a pass-through command using the display application if you are requesting an expansion level of 3 or higher.

Audit record formats

Information Exchange provides two levels of audit record data. The length of the Level-1 message audit record is 254 bytes and contains all fields up to and including AOEMSGID (field 30). The length of the Level-2 message audit record is 326 bytes and contains AOSNDEDD (field 3 1) through AORCVCMT (field 42) in addition to AUSERID (field 1) through AOEMSGID (field 30). For both levels 1 and 2, all fields are in character format.

Level 1 audit record format

The following record layout represents the Level-1 format of the audit records the Audit Retrieve command places in your Information Exchange mailbox.

AUSERID (field 1)

This field contains the Information Exchange address of the user who sent or received the detailed message group. The first 8 characters represent the user's Information Exchange account ID; the last 8 characters are the user ID.

ARECTYP (field 2)

This field contains one of the following numeric characters:

This value:	Indicates:
0	AUSERID is the sender of a message to APARTNER
1	AUSERID is the sender of a message to AUSERID (self)
2	APARTNER is the sender of a message to AUSERID

APARTNER (field 3)

This field contains the extended Information Exchange ID of the trading partner of AUSERID for this message group. If the indicated user is on the same system, the first 4 characters are blanks. If not, the first character is I, followed by the 3-character system ID of the user's system. The last 16 characters are the account ID and user ID, as in AUSERID.

AGROUPID (field 4)

This field contains the identifier for a message group. Each message group is assigned an internal control number.

ASTATFLG (field 5)

This field indicates the status of the message group:

This value:	Indicates:
0	Either the sender sent the file and Information Exchange has not delivered it to the receiver; or the sender sent the file to a remote system and Information Exchange has not sent it
1	The intended user received the file
2	The receiver purged the file
3	The file is in the user's mailbox, waiting to be received
4	The file was sent to a system which is not an Information Exchange system

ASTATUS (field 6)

This field contains a short description of the status value indicated in

ASTATFLG. APURGFLG (field 7)

This value:	Indicates:
000	The message group was not purged.
001	The file expired and Information Exchange did not deliver it
002	The sender canceled the file.
003	The intended receiver canceled the file.
004	A service administrator other than the sender or the intended receiver canceled the file.
005	The network canceled the file because of problems with the message group or because the user requested it.
010	The file could not be delivered.
011	Information Exchange could not deliver the file immediately.

This field indicates the reason the message group was purged:

APURGED (field 8)

This field contains a short description of the value indicated in APURGFLG; or if the message group was not purged, this field contains blanks.

AALIAS (field 9)

If the sender of the message group was AUSERID and the file was sent to an alias, this field contains that alias.

APRIORITY (field 10)

This field contains the message priority indicated on the send command.

ANMSGCLS (field 11)

This field contains the Network Message Class field of the message group.

AUMSGCLS (field 12)

This field contains the user class field of the message group.

AMSGNAME (field 13)

This field contains the name of the message group.

AMSGSEQI (field 14)

This field contains the sender's assigned message sequence-in number.

ASYSTYP (field 15)

This field contains the sender's system type.

ASYSLVL (field 16)

This field contains the sender's system level.

AMSGCNTR (field 17)

This field contains the number of files in the message group, excluding any CDH file. **AMSGSIZE (field 18)**

This field contains the total text size of the message group, excluding any Information Exchange headers or CDHs.

ARC VARCH (field 19)

This field contains the receiver's archive ID or the session key of the session in which it was received. If the status is not received, this field contains blanks.

ASNDDATE (field 20)

This field contains the date the file was sent, in the format YYMMDD.

ASNDDATE (field 21)

This field contains the time the file was sent, in the format HHMMSS.

ARC VDATE (field 22)

This field contains the date the message group was either received or purged, in the format YYMMDD. If the status is not received or not purged, this field contains zeros.

ARC VTIME (field 23)

This field contains the time the message group was received or purged, in the format HHMMSS. If the status is not received or not purged, this field contains zeros.

AMSEQOUT (field 24)

This field contains the sequence-out number assigned by Information Exchange to the first message of the message group when it was received.

AOETYPE (field 25)

This field contains one of the following numeric characters:

This value:	Indicates:
0	This is not recognized as one of the supported EDI data types.
1	X12 data
2	UCS data.
3	EDIFACT data.
4	UN/TDI data.

AOE SEND (field 26)

This field contains the EDI sender ID and is for EDI use only. The format is:

This EDI data type:	Has the following format:
X12	15 alphanumeric characters, left-justified, and padded on the right with blanks.
UCS	2 to 12 alphanumeric characters, left-justified, and padded on the right with blanks
EDIFACT	Up to 17 characters of the data element 0004 in composite data element S002 (interchange sender).
UN/TDI	If the first subelement of the sender ID element (FROM: 1) is not blank, then it is used as the EDI sender ID. Otherwise, up to 17 characters of the second subelement of the sender ID (FROM:2) are used.

AOESQUAL (field 27)

This field contains a qualifier that gives more information about the EDI sender. The format is:

This EDI data type:	Has the following format:
X12	2 alphanumeric characters, left-justified, and padded on the right with blanks.
UCS	No qualifier was used; the field is blank.
EDIFACT	4 alphanumeric characters.
UN/TDI	No qualifier was used; the field is blank

AOERCVR (field 28)

This field contains the EDI receiver ID and is for EDI use only. The format is:

This EDI data type:	Has the following format:
X12	15 alphanumeric characters, left-justified, and padded on the right with blanks.
UCS	2 to 12 alphanumeric characters, left-justified, and padded on the right with blanks
EDIFACT	Up to 17 characters of data element 0010 in composite data element S003 (interchange recipient).
UN/TDI	If the first subelement of the receiver ID element (UNTO: 1) is not blank, then it is used as the EDI receiver ID. Otherwise, up to 17 characters of the second subelement of the receiver ID (UNTO:2) are used

AOERQUAL (field 29)

This field contains a qualifier that gives more information about the EDI receiver. The format is:

This EDI data type:	Has the following format:
X12	2 alphanumeric characters, left-justified, and padded on the right with blanks.
UCS	No qualifier was used; the field is blank.
EDIFACT	4 alphanumeric characters.
UN/TDI	No qualifier was used; the field is blank

AOEMSGID (field 30)

This field contains the message ID, which has two elements: the message name (8 bytes) and the EDI sequence number (5 bytes). The format of the message ID is:

This EDI data type:	Has the following format:
X12	The 9-digit interchange control number, right-justified, and padded on the left with zeros
UCS	The 1- to 5-digit interchange control number, right-justified, and padded on the left with zeros.
EDIFACT	Up to 8 characters of the sender's data element 0020 (interchange control reference), followed by up to 5 characters of the receiver's data element 0022 in composite data element S005 (recipient's reference and password). Each of these elements is treated separately; both are left-justified and padded on the right with blanks.
UN/TDI	Up to 8 characters of the sender's reference element (SNRF), followed by up to 5 characters of the recipient's reference element (RCRF). Each of these elements is treated separately; both are left-justified and padded on the right with blanks.

Preparing an audit trail report

Expedite/CICS provides a sample program, AUDRPT, that will process and produce a summary report of the details from the audit data. A printed version and explanation of the sample audit report and program is provided in the *Information Exchange Interface Programming Guide*.

This program is provided as-is with no warranty and does NOT support extended timing fields in the audit record.

To use this program, proceed as described below:

1. Issue an audit retrieve so that the audit trail is placed in your mailbox.
2. Issue a batch receive or a single receive into an extrapartition TDQ to receive the audit data. The data should be received into a batch data set wrapped into 254 byte records.
3. Run the compiled audit report program against this data set, using INFILE and OUTFILE DD names as the input and output data set names, respectively.

Level-2 audit record format

The Level-2 audit record consists of the Level-1 fields plus the following.



NOTE: There is a per-character charge for audit record data provided by the Level-2 format. Contact your marketing representative for details.

AOSNDEDD (field 31)

This field contains the date the send process ended, in the format YYMMDD.

AOSNDEDT (field 32)

This field contains the time the send process ended, in the format HHMMSS.

AOSNDCMD (field 33)

This field contains the date Information Exchange committed the message during the send process, in the format YYMMDD.

AOSNDCMT (field 34)

This field contains the time Information Exchange committed the message during the send process, in the format HHMMSS.

AOSNDROD (field 35)

This field contains the date the message was available for the intended receiver to retrieve, in the format YYMMDD.

AOSNDROT (field 36)

This field contains the time the message was available for the intended receiver to retrieve, in the format HHMMSS.

AORCVSTD (field 37)

This field contains the date the receive message process started, in the format YYMMDD.

AORCVSTT (field 38)

This field contains the time the receive message process started, in the format HHMMSS.

AORCVEDD (field 39)

This field contains the date the receive message process ended, in the format YYMMDD.

AORCVEDT (field 40)

This field contains the time the receive message process ended, in the format HHMMSS.

AORVCMD (field 41)

This field contains the date Information Exchange committed the message during the receive process, in the format YYMMDD.

AORVCMT (field 42)

This field contains the date Information Exchange committed the message during the receive process, in the format HHMMSS.

Querying a mailbox

Use the Message Queue Query command to see a list of all the files in your Information Exchange mailbox.

The information obtained in response to the Message Queue Query command can be very useful for several reasons. The available records show you all of the files waiting to be received from your mailbox. Using this information, you can build Receive Message commands to receive all of these files. In addition, the available records provide a unique message key for each of the files in the mailbox. You can use this information on a Receive Message command to receive a specific file.

When a message queue query is issued, the number of items returned depends on the data transmission size in use on the system. If there is more data to retrieve from the Information Exchange mailbox, this is indicated in the message queue query response. Further message queue query commands must then be issued to retrieve the remaining data. When there is no more data left to retrieve, Expedite/CICS passes message HI675 to the calling application.

There are two ways in which a user can issue a message queue query command:

- Using the Display Application (see the Expedite/CICS Display Application User's
- Using the Program Interface (see Chapter 6, "Using Expedite/CICS commands in your application")

Processing batch data using Expedite/CICS

Similar to many CICS online applications, Expedite/CICS can move data back and forth between batch and online environments. For example, a large percentage of data that is exchanged electronically is created by a batch application, translated by a batch EDI translator, and then sent to the appropriate trading partners through a batch communication interface to Information Exchange. Three basic approaches you can use for batch processing are:

1. Use VSAM data sets with appropriate VSAM share options to enable data created in one environment to be read in the other environment.
2. Use extrapartition data (CICS Transient Data); this is implemented by either:
 - a. Submitting a batch job using the internal reader facility
 - b. Using CICS master terminal or application program commands to open and close data sets, thus making them available to the other environment.
3. Use the batch interface supplied with Expedite/CICS.

You can use a combination of these approaches. Additional programming alternatives for sending and receiving batch data are provided in “Designing an application” on page 70.



NOTE: If batch processing is a primary requirement for your organization and yours is an MVS installation, you should consider using Expedite Base/MVS.

The major topics discussed in the chapter are listed below.

Using VSAM data sets as a batch interface	160
Using CICS master terminal commands in a batch interface	160
Using the MVS internal reader batch interface.....	162
Using the Expedite/CICS batch send interface	164
Using batch send processing.....	167
Using Expedite/CICS batch receive interface.....	170

Using VSAM data sets as a batch interface

VSAM data sets can be used for batch interface without additional application programming by simply setting up operational procedures. This approach is easy to implement but data integrity can be adversely affected unless the online application and batch application run at different times during the day. Care must be taken to avoid reading and writing to the same data set at the same time with different applications.

VSAM data sets can be closed and reopened to access received data. An example of this alter-native is provided in “Invoking a receive program internal to CICS” on page 109.

Using CICS master terminal commands in a batch interface

Master terminal commands in batch interface may be used for batch interface without additional application programming by simply setting up operational procedures. Unlike using VSAM data sets, this strategy presents no danger of reading and writing to the same data set at the same time by different applications. Implementation procedures for sending and receiving data are provided below.

Sending batch data

1. Use the CICS CEMT command to close the extrapartition data set.
2. Run the batch job to create or update the data set. If you have formatted EDI data, this could include running the batch translator step to put the data into X12, UCS, EDIFACT, or UN/ TDI format.
3. Use the CICS CEMT command to open the extrapartition data set.
4. Log on to Information Exchange using the Expedite/CICS Display Application.
5. Use the Display Application to access the Send File Request panel and issue a send request from the TDQ. If you need help, refer to the Expedite/CICS Display Application User’s Guide.



NOTE: When sending an extrapartition transient data queue (TDQ), you must close it and reopen it within CICS before each successive send. This repositions CICS to the beginning of the TDQ.

Receiving batch data

1. Use the CICS CEMT command to close and open the extrapartition data set. This positions CICS to Record 1.
2. Log on to Information Exchange using the Expedite/CICS Display Application.
3. Use the Display Application to access the Issue Single Receive Request panel and issue a receive request, directing the mail to the TDQ which must be defined in the DCT. If you need help, refer to the *Expedite/CICS Display Application User’s Guide*.
4. When the receive has completed, use the CICS CEMT command to close the extrapartition data set. This positions CICS to Record 1.

5. When the Receive request is complete, submit a batch job to process the data.
6. After the batch job completes, use the CICS CEMT command to open the extrapartition data set so Expedite/CICS can receive additional data into the TDQ that is received later.

Using the MVS internal reader batch interface

To submit a batch job using the internal reader, you must write a simple CICS application program that uses steps similar to the procedure described in “Using CICS master terminal commands in a batch interface” on page 148. In this approach, however, the commands are issued by a program or programs. To help you get started, two sample programs are described:

- Program A initiates an Information Exchange session and starts a Continuous Receive.
- Program B, and associated programs it may call, receives data from CICS and either processes the data or passes it to another program.



NOTE: The sample programs describe workable solutions; you may, of course, use other variations.

Program A

Set up your CICS system so that Program A automatically starts when you initialize the CICS subsystem. Program A performs the following:

1. Build a TSQ with current job number equal to 1.
2. Use the Expedite/CICS program interface to issue a Session Start command to Information Exchange.
3. Issue a Continuous Receive command for a given mailbox as follows:
 - You must specify the name of the receive program
 - You may optionally specify a user class to refine the request.
4. Terminate upon completion.

Program B

CICS Program B has several processing options. It could:

- Start other CICS transactions or link to other programs to process the data.
- Store the data in an extrapartition TDQ.
- Examine the data and, based on information in the data, store the data in a VSAM data set.

In the following scenario, it is assumed the sole purpose of Program B is to submit a batch job to process data when it is received from Information Exchange. Program B must build a batch job stream made up of JCL and data that is submitted to the batch facilities of the operating environment through the internal reader facilities. The following storage facilities are used:

- A TSQ is used to save the current job sequence number; that is, the number of the last job submitted to the internal reader.
- An input extrapartition data set is used to track the job sequence number of completed jobs.
- An output extrapartition data set is the destination to which received data is written. The steps Program B performs are described in “Program B procedure” below.

Program B procedure

1. ENQ (CICS) on any unique resource name; this ensures single threading.
2. Get the current job sequence number from the saved TSQ.
3. Close and reopen the input extrapartition data set to position CICS to Record 1.
4. Read a record from the input extrapartition data set.
5. If the job sequence number of the record in Step 4 is less than the current job sequence number, the previous job is not complete; repeat Step 4 until the record job sequence number equals the current job sequence number.
6. Close, open, and write received data to the output extrapartition data set.
7. Add 1 to the current job sequence number and save in the TSQ.
8. Submit a batch job (and pass the job sequence number). The batch job:
 - a. Processes data received from your Information Exchange mailbox to the output extra-partition data set.
 - b. Translates any EDI data into your specified format and updates your data base.
 - c. Writes the job sequence number in the input extrapartition data set so the process can repeat when the next message arrives.
9. DEQ (CICS) from resource name and exit.

**NOTE:**

1. The ENQ and DEQ steps synchronize the process so that received data does not overlay previously received data
2. If the batch job does not run successfully, all subsequently received data is suspended in CICS. This problem can be avoided by using a keyed-sequence data set instead of an extrapartition data set. In this case, Program B and the batch job perform the following tasks
 - a. Places the data in a keyed VSAM file
 - b. Issues the batch job specifying the beginning and ending key
 - c. Terminates

The batch job reads and processes the data based on specified keys

3. The batch job should be read-only against the VSAM file. All updates are done under CICS control.

Using the Expedite/CICS batch send interface

You can send files from batch to Information Exchange using the Expedite/CICS batch send program. The batch send program places the batch file into a VSAM data set, and waits for Expedite/CICS to send the file to Information Exchange. After the file is sent, Expedite/CICS notifies the batch send program. The batch send program updates a log file with information on the status of the send request and then terminates.



NOTE: The batch send function is monitored and executed automatically by a CICS transaction, EXPS, which you add to the Program Control Table (PCT) along with a few other table entries. Refer to the Expedite/CICS Program Directory, for more information about the tables you need to update.

Batch send I/O

The batch send inputs include the batch file to be sent and a set of input cards that consists of keywords designating the sender, receiver, and the data type of the batch file.

The output of batch send is one or two lines of messages, issued by either phase 1 (batch) or phase 2 (online). If the job runs successfully, the message displays the total number of bytes sent to a receiver's mailbox. In case of error, the message displays the cause of the error. All messages are self-explanatory.

Batch send invocation

The batch send program requires JCL, a sample of which is provided in the JCL library member, BATCHSND. The JCL performs two tasks:

1. IDCAMS REPRO: Copy the file to be sent into a temporary variable length disk file.
2. EXPBSEND: Execute the batch send program.

A printout of the JCL is provided below.

```
//USERIDA JOB (950), 'USEROD', NOTIFY=USERID,
//MSGCLASS=X, CLASS=A
//*****
/** EXPEDITE/CICS *
/** *
/** THE FOLLOWING JOB VARIABLES NEED TO BE CHANGED: *
/** *
/** JOB CARD *
/** XXXXXXXX.INPUT FILE - BATCH INPUT FILE *
/** XXXXXXXX - HIGH LEVEL QUALIFIER *
/** UUUUUU - UNIT *
/** VVVVVV - VOLUME SERIAL NUMBER *
/** *CYLS* - PRIMARY CYLINDERS *
/** *SEC* - SECONDARY CYLINDERS *
/** CARD PARAMETERS - INPUT TO BATCHSEND PROGRAM *
/** *
/** A NEW KEYWORD OF CONSOLE=YES HAS BEEN ADDED. THIS CAUSES THE *
/** INFORMATIONAL MESSAGES TO APPEAR ON THE SYSTEM CONSOLE. *
/** *
/** PLEASE NOTE: THE COBOL II SUBROUTINE LIBRARY MUST BE ADDED TO *
/** THE STEPLIB. *
//*****
//REPRO EXEC PGM-IDCAMS.REGION=4M
Chapter 5. Processing batch data using Expedite/CICS
Using the Expedite/CICS batch send interface
//DD1 DD DSN=XXXXXXXX.INPUT.FILE, DISP=SHR
//DD2 DD DSN=&&TEMP, DISP=(NEW, PASS),
// UNIT=UUUUUU, SPACE=(CYL, (*CYLS*, *SEC*), RLSE),
// DCB=(RECFM=VB, LRECL=32004, BLKSIZE=32009),
// VOL=SER=VVVVVV
//SYSPRINT DD SYSOUT=X
```



```

//SYSIN DD *
REPRO IFILE(DD1) OFILE(DD2)
/*
/**
//BTCHSEND EXBC PGM-EXPBSEND,REGION-4M
// COND=(4,LT,REPRO)
//STEPLIB DD DSN-XXXXXXXXX,H0CA450.SEXPLOAD,DISP-SHR
// DD DSN-(LE RUNTIME LIBRARY),DISP-SHR
//EXPDPTF DD DSN-XXXXXXXXX,EXPDPTF,DISP-SHR
//EXPDSRC DD DSN-XXXXXXXXX,EXPDSRC,DISP-SHR
//BATCH DD DSN-*.REPRO.DD2,DISP=(SHR,PASS),DCB=BUFNO=30
*****
/* THE CARD FILE CONTAINS KEYWORD PARAMETERS. THE FROMACCT, *
/* FROMUSER, TOACCT, TOUSER, PASSWORD,AND FILETYPE ARE MANDATORY *
/* FOR UNFORMATTED DATA. THE TOACCT AND TOUSER ARE IGNORED WHEN *
/* SENDING EDI DATA, SO THEY CAN BE LEFT OUT. *
*****
/*
//SYSOUT DD SYSOUT--*
//SYSSPRINT DD SYSOUT--*
//SYSCOUNT DD SYSOUT--*
//SYSDBOUT DD SYSOUT--*
//CARD DD *
FROMACCT-ACCT, FROMUSER-USERID, TOACCT-ACCT, TOUSER-USERID,
FILETYPE-O, PASSWORD-PASSWORD, USERCLAS-USERCLAS, CONSOLE-YES
/*
/**

```

Batch send keywords

The batch send program reads the values of eight keywords from a set of input cards. The keywords are:

FROMACCT:

The sender's account must be entered.

FROMUSER:

The sender's user ID must be entered.

TOACCT:

The receiver's account must be entered when sending unformatted data (LL, PC, and OTHER). This field is ignored when sending EDI data.

TOUSER:

The receiver's user ID must be entered when sending unformatted data (LL, PC, and OTHER). This field is ignored when sending EDI data.

LISTNAME

If you are sending to a list, enter the name of the list.

FILETYPE:

One of the following types of data must be entered:

A	PC data
B	LL data
O	OTHER
E	EDI, file consists of one or more envelopes

USERCLAS:

The user class is an optional field.

PASSWORD:

The sender's Information Exchange password must be entered.

CONSOLE:

If this keyword is present, an informational message is displayed on the system console.

The following rules apply to keywords:

- All keywords must be followed by an equal sign and a value.
- Separate keyword parameters must be separated by a comma.
- Keyword parameters may be in any order.
- Blanks between keywords are ignored.
- Keyword parameters can be entered in one line up to column 72.
- One keyword parameter cannot be split into two lines.

The following is an example of keywords:

```
FROMACCT=GXS, FROMUSER=GXS001, TOACCT=GXS, TOUSER=GXS002,  
FILETYPE=O, USERCLAS=EXPCICS, PASSWORD=GXS001, CONSOLE=YES
```

Using batch send processing

The Expedite/CICS batch send function is provided to enable you to send data that was created in a batch environment to Information Exchange. The topics under this heading provide information about how the process works and about various options you can use.

Processing batch send data

The Expedite/CICS batch send function is accomplished by the interaction between two programs, the Batch Send Program and the Online Batch Program, and their associated I/ OVSAM data sets, EXPDPTF and EXPDSRC.

- In MVS, Batch Send has write access to its output data set, EXPDPTF, and read-only access to its input data set, EXPDSRC.
- In CICS, Online Batch Send has write access to its output data set, EXPDSRC, and read-only access to its input data set, EXPDPTF. Online Batch Send runs at an interval specified on the Display Application Define System Options panel. The default batch send interval is 0000 seconds. To use the batch send function, you should change this value to 0015.

The interaction between the two programs is described below.

The batch job does the following:

1. When batch send JCL is submitted, Batch Send copies the input to a temporary data set.
2. Expedite/CICS program EXPBSEND reads and processes the input card that specifies session details; for example, Account/Userid, password, and user class.
3. A batch send control record is created in the EXPDPTF data set.
4. Batch data from the temporary data set is then written to EXPDPTF. The data is now ready to be sent to Information Exchange.

Online Batch Send Program does the following:

Online Batch Send checks EXPDPTF at the predetermined interval and performs the steps described below.

1. Inspects EXPDPTF at the predetermined interval:
 - If no send data is found, Online Batch Send reschedules itself, and ends.
 - If send data is found, the batch control record is read from EXPDPTF and written to EXPDSRC.
2. Determines if the user has an active session with Information Exchange and issues a session start if necessary.
3. Formats and passes a send command to the Expedite/CICS command processor.

Expedite/ CICS :

 - a. Reads the data from EXPDPTF.
 - b. Writes the data to EXPDAT and starts the online send process.

For details on how the data is actually sent to Information Exchange and whether processing is synchronous or asynchronous, see “Defining how send data will be processed” on page 87.

4. Updates the batch send control record in EXPDSRC with the result of the send request.
5. Ends the user session if the user was not active on Information Exchange when the batch send request was issued.
6. Reschedules itself and ends.

Batch job does the following:

Monitors the batch send control record in EXPDSRC. This is done only for a short time, which is calculated based on the size of the data being sent. One of the following occurs:

- If the control record does not indicate a result in the specified time, the batch job ends with a time-out message, suggesting that the batch send interval should be checked on the Display Application system options panel.
- Batch Send:
 1. Reads the result in EXPDSRC
 2. Updates the batch send control record in EXPDPTF
 3. Completes the job.

Sample successful batch send output

Throughout the process, messages are written to the output device for purposes of information. A processing summary is provided below.

```
*****
BEGINNING BATCH PROCESSING: 10:21:36
BEGINNING ONLINE PROCESSING: 10:21:36
CURRENT TIME: 10:21:36
END OF ONLINE PROCESSING: 10:21:36
*****
SEND FILE COMPLETED SUCCESSFULLY
TOTAL RECORDS SENT : 19 TOTAL BYTES SENT : 1,520
*****
```

In addition to the example illustrated above, the processing summary indicates whether or not the processing was successful:

- Return code 00 indicates successful completion
- Return code 08 indicates an error.

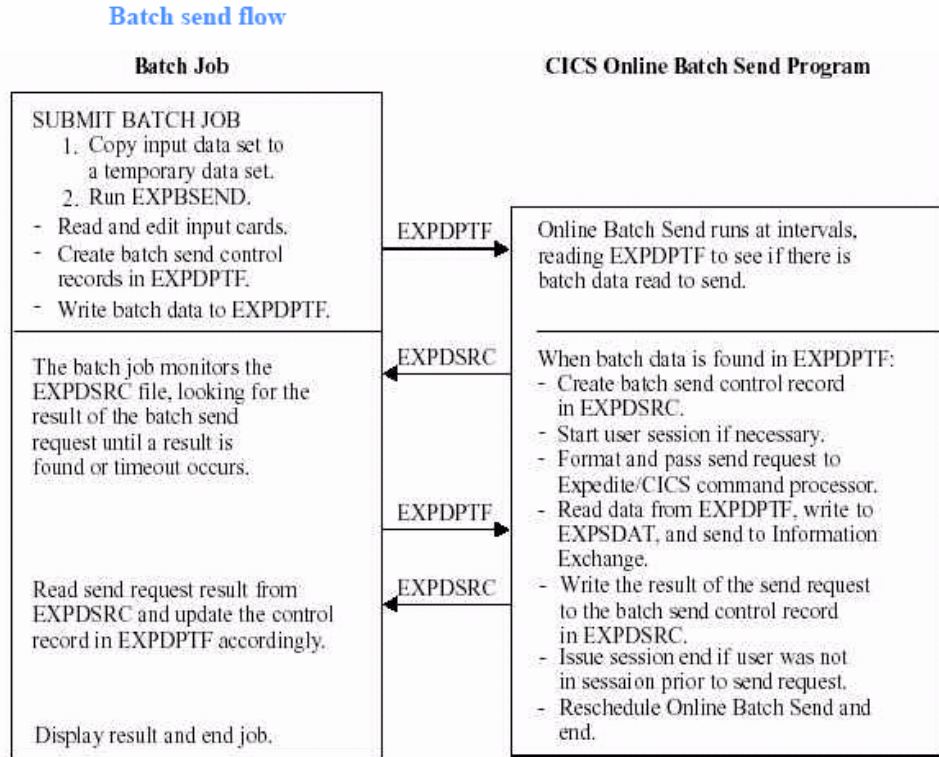

Figure 14. Batch send flow

Batch send error processing

There is little error processing of the batch send function itself. If the request fails, appropriate messages are written to the output device and the job control return code is set to 08. After the problem has been corrected, the batch job must be resubmitted. During the actual sending of batch data, normal recovery processing for send requests applies. For more information, see “Processing send request errors” on page 91.

Using Expedite/CICS batch receive interface

Expedite/CICS batch receive is available only through the Display Application. You provide the information about the batch file in which to store the files and messages on the Issue Batch Receive Parameters panel. Expedite/CICS saves these batch receive inputs in the EXPDSRC file and issues a Single Receive command.

When the single receive completes, the data is placed in the receive data (EXPRDAT) file. If the issuing system is MVS, a batch job is submitted from CICS to process the data and place it in the data set specified in the Data set name field.

Use the View option to see if batch receive processing was successful. Initially, after the data is received from Information Exchange, a status of COMPLETE is indicated for data successfully received from Information Exchange. Expedite/CICS eventually updates the status to RECEIVED if the job was successful or to HIxxx if not. To avoid excessive reads during peak processing time, this status is not updated between the time specified on the Define System Options panel.

Batch receive invocation

To receive your mail into a batch file, begin on the Display Application Main Selection Menu.

1. Issue: =1.B

Expedite/CICS displays the Issue Batch Receive Parameters panel, with your account ID, user ID, and existing default values already filled in.

```

EXPMSRC1          Issue Batch Receive Parameters
FOR:
Account   ACCT      From: System ID      <      >
Userid    USER     Account / Userid <      > <      >
          -or- List name <      >
          -or- Alias name <      >
          User class < MYMSG >

TO: File type      < 0 >      (A=CRLF, B=LL, E=EDI, O=Other)
Data set name     < MYDATA.SET >
Retain header data < Y >      (Y - Keep IE headers / N - Discard)
                  (E - Extend/Discard / F - Extend/Keep)
Receive EDI       < >      (Y=EDI only, N=NON-EDI, Blank=Both)
Handle records as < W >      (S-Split / W-Wrap / V-Variable data)
Max record length < 00080 >  (00000 - 28000 Characters)
< //USERIDX JOB (000), 'BATCH RECEIVE', CLASS=A, >
< // MSGCLASS=X, MSGLEVEL=(1,1), NOTIFY=USERID, >
< // USER=      , PASSWORD= >
< /*JOBPARM P=PROCOL >
JCL procedure name < EXPBSUB >
HI308 ENTER FIELD INFORMATION AND PRESS PF5 TO RECEIVE MESSAGE(S).

Command ==>
PF1=Help PF5=Receive PF12=Cancel

```

2. Complete the fields and, when ready to start receiving, press PF5. If you need help with field information, refer to the *Expedite/CICS Display Application User's Guide*.

**NOTE:**

1. You may call this procedure by another name when you install the product. Use the same name in the panel. This procedure will run program EXPBRCV1, which reads the EXPDAT file and writes the formatted data to the file specified in the procedure, file name PTFOUT.
2. Expedite/CICS uses the information in the Job card field to submit the batch job to for processing. Expedite/CICS also saves this information and displays it each time you access this option.

The sample procedure, EXPBSUB, is provided in the installation JCL data set. The procedure name must have been defined during installation, as explained in the Expedite/CICS Program Directory. You must change the STEPLIB DD card before you use the procedure. You may add more steps, but the first three steps must be left as provided. A sample job stream for the batch receive program follows.

```
//EXPDSUB PROC
//LISTC EXEC PGM=IDCAMS
//SYSPRINT DD SYSOUT=*
//*
//IEFBR14 EXEC PGM=IEFBR14,COND=(4,GT,LISTC)
//DD1 DD DSN=&DSN,DISP=(NEW,CATLG,DELETE),
// UNIT=SYSDA, SPACE=&SPC,
// DCB=(RECFM=&FM, LRECL=&RECL, BLKSIZE=&BLKS)
//SYSPRINT DD SYSOUT=*
//SYSUDUMP DD SYSOUT=*
//*
//EXPDPDF1 EXEC PGM=EXPBRCV1, REGION=6M
//STEPLIB DD DSN=*****.H0CA450.SEXPLOAD,DISP=SHR
DD DSN=(LE RUNTIME LIBRARY),DISP=SHR
//EXPDSRC DD DSN=&EXPDSRC, DISP=SHR,
// AMP=(AMORG,'BUFNI=10','BUFND=40')
//EXPDPDF DD DSN=&EXPDPDF, DISP=SHR,
// AMP=(AMORG,'BUFNI=10','BUFND=40')
//PTFOUT DD DSN=&DSN, DISP=SHR, DCB=BUFNO=40
//SYSPRINT DD SYSOUT=*
//SYSOUT DD SYSOUT=*
//REPORT1 DD SYSOUT=*
//SYSUDUMP DD SYSOUT=*
//*
// PEND
//* END OF EXPDSUB
```

Batch-receive processing

Expedite/CICS provides a batch receive feature that allows the receiving of files into a sequential data set, which is not defined to CICS. This topic provides an overview of how Expedite/CICS processes batch receive requests. The characteristics of batch receive processing are listed below.

Before you begin:

1. If you use the Expedite/CICS batch receive function, you should enable archiving. For archiving information, refer to the *Information Exchange Administration Services User's Guide*.
2. If you use the batch processing often, it is recommended you order Expedite Base/MVS, which is designed primarily for the batch environment and provides additional features.

A batch receive request is processed by Expedite/CICS exactly as explained in the *Expedite/CICS Display Application User's Guide*. The general flow of the batch receive process is illustrated in Figure 15, in which the request is issued, and in Figure 16 on page 160, in which the request is processed.

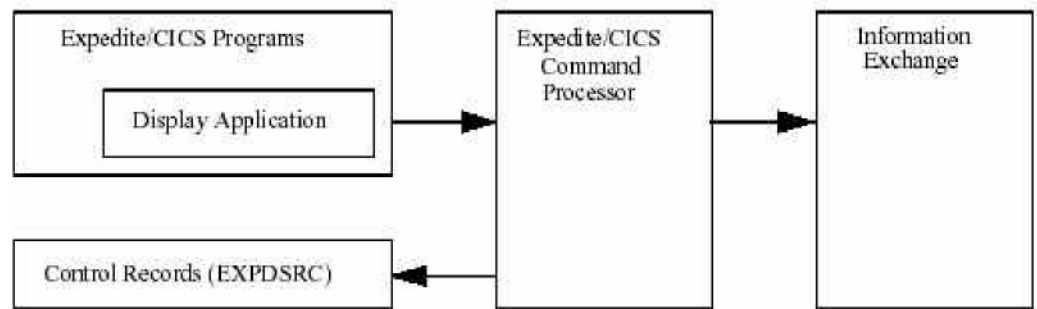

Figure 15. Issuing a batch receive request

1. A batch receive request is issued from the Display Application.
2. Expedite/CICS creates a receive control record in EXPDSRC.
3. Expedite/CICS sends the receive request to Information Exchange.

4. Expedite/CICS returns control to the user, displaying a message on the panel.

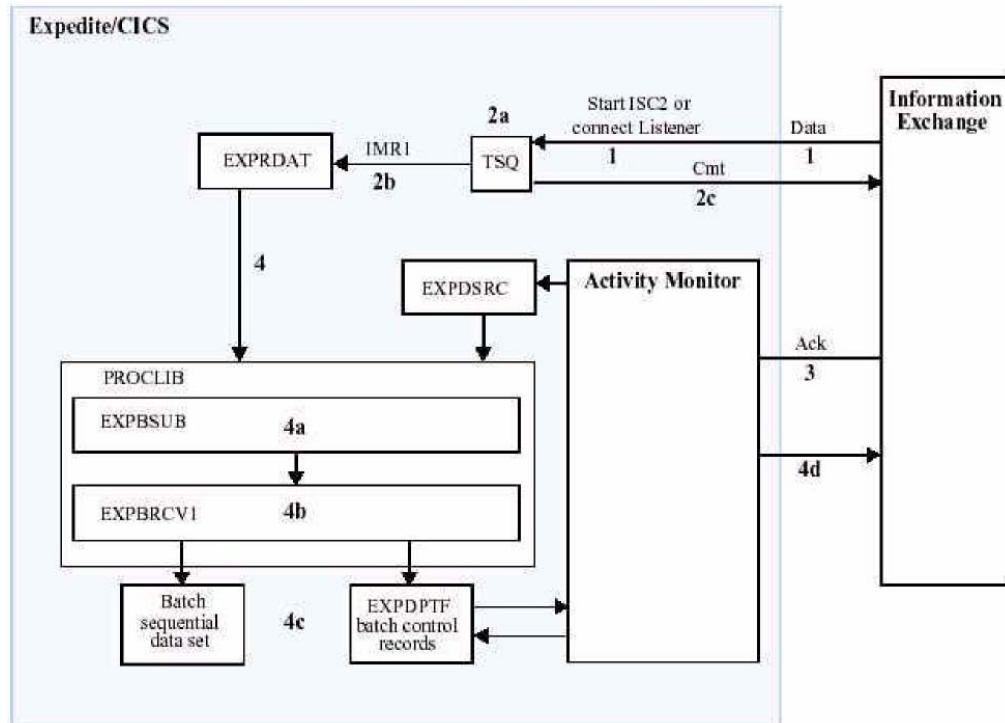

Figure 16. Processing a batch receive request

1. Information Exchange sends data asynchronously to Expedite/CICS, which starts Trans-action ISC2 on the CICS region if you are using SNA communication, or connects to the Expedite/CICS listener if you are using TCP/IP communication.
2. Expedite/CICS:
 - a. Writes received data to a TSQ and starts Transaction IMR1.
 - b. Writes data to the receive data (EXPRDAT) VSAM file.
 - c. Sends a commit response to Information Exchange when all data is received in EXPRDAT and updates the receive control record with a status of COMPLETE.
3. Upon receipt of the commit response, Information Exchange:
 - Deletes the data from the mailbox.
 - Generates an acknowledgment, if requested by sender.
4. Expedite/CICS prepares and writes MVS JCL to an internal reader.
5. The batch job:

- a. Calls procedure EXPBSUB to read control records from EXPDSRC and data records from EXPRDAT.
- b. Passes control to EXPBRCV1 to open (create if necessary in MVS) the user's output data set, writes the data, and closes the data set.
- c. Updates the batch receive record in the EXPDPTF data set with the result of the receive.

Prior to submission of the batch job, the receive status online is COMPLETE. When the batch program updates the batch control record in EXPDPTF with the result of the receive, the activity monitor reads the status from EXPDPTF and updates the online batch control record with the results of the receive (either RECEIVED or HIxxx). Following this, if the result was successful, the data records are purged from the EXPRDAT file. To avoid excessive reads during peak processing time, such updates are not done between the times specified on the Define System Options panel.

6. If receive processing is interrupted, the activity monitor resets or restarts receive requests with status, NODATA, INCOMPLT, or COMPLETE.
7. If an error occurs in the batch job:
 - a. The batch job updates the batch receive record in the EXPDPTF file to indicate the error.
 - b. When the Expedite/CICS activity monitor runs, it inspects the control record in the EXPDPTF file, as described previously, and marks the control record in the EXPDSRC file in error. The data is retained in the EXPRDAT file until it is purged by the user or automatically by the activity monitor after the number of days specified in the Not-Sent Not-Received Retention parameter in the Define System Options panel.

Additional details include the following:

- The online batch receive record, which can be viewed through Process and View options under the Receive Selection Menu, is marked as COMPLETE when the data is received and stored in the Expedite/CICS receive data (EXPRDAT) file.
- No links are provided for user information exit or user exception programs.
- A sample procedure, EXPBSUB, for this batch receive process is supplied with Expedite/ CICS and must be customized for your installation.

The activity monitor purges expired batch receive control records associated with successful batch receive requests. The receive retention period is specified in the user's profile. To avoid excessive reads during peak processing time, this is not done between the time specified on the Define System Options panel.

Failed Batch receives cannot be released and retried from the Display Application. The data can be retrieved from archive if it is activated in Information Exchange, and then the batch receive request can be reissued. As a last alternative, you can manually retrieve the data from the receive data (EXPRDAT) file.

Job output

You can view batch job output to determine if the job ran successfully. The return code will be either zero to indicate successful completion or 08 to indicate an error occurred. In MVS, if the job completed successfully an output report is produced similar to the sample below. If the job failed, the report will indicate that an error occurred, or there will be no report.

```
EXPBRV1 EXPEDITE/CICS BATCH RECEIVE REPORT PAGE 1
05/12/97 ATAP USER02
BATCH #: 00000007
FROM ACCT FROM USER MSG CLAS DATE/TIME SENT DATE/TIME RCVD NO OF
BYTES ACCT1 USER02 MESS2 98/04/16 14:23:36 05/12/98 14:04:59 8,488
```

Using Expedite/CICS commands in your application

Your application must pass all commands and data that it sends to Information Exchange through the command processor. The command processor handles all the sending and receiving of data to and from Information Exchange. This chapter describes each Expedite/CICS command and response you use when developing an Expedite/CICS application to communicate with Information Exchange. The commands are presented in alphabetical order:

Alias Inquiry command	179
Archive Retrieve pass-through command	182
Audit Retrieve command	185
Browse Library Member	190
Cancel pass-through command	192
Define Alias command	197
Define Library command	201
Delete Library command	205
Delete Library Member command	207
Library PutMember command	209
Library Search command	214
List Define command	217
List Library command	222
List Library Member command	227
List Verify command	230
Load Test Messages pass-through command	233
Message Inquiry pass-through command	235
Message Queue Query command	239
Probe command	245
Purge Message command	251
Receive Message command	253
Retrieve Library Member command	268
Retrieve Library Member CDH command	272
Send file command	274
Session End command	285
Session Inquiry command	288
Session Start command	294
Set Administrative Response File command	302

Using copybooks

A copy of the command formats is provided on the product installation tape. The copybook names correspond with the command names except the first three characters are EXP rather than SDI, as indicated in the text under the command headings presented later in this book. Copy the command formats into your program's workspace section to be used as the COMMAREA your program passes to the command processor.



NOTE: Copybook names that used to begin with SDI now begin with EXP. For example, command SDIARTV corresponds to the copybook EXPARTV.

Pass-through commands

The following commands are not directly supported by the Expedite/CICS command processor. However, your program can issue these commands as pass-through commands to Information Exchange.

This command:	Can be used to:
SDIARTV	Retrieve archived groups of mail (page 168)
SDICNCL	Cancel mail that you have sent (page 178)
SDIINQM	Inquire about mail in your mailbox (page 220)
SDILTST	Load test messages (page 218)

Command responses

Most commands produce an immediate response. The following commands can result in responses that are placed in your mailbox:

- Archive Retrieve
- Audit Retrieve
- Cancel
- Library PutMember
- List Verify
- Load Test Messages
- Probe (asynchronous)
- Retrieve Library Member
- Send File

Alias Inquiry command

Use the Alias Inquiry command to determine the real Information Exchange address associated with a given alias. If the user of the alias is on a different system, this is also identified.

Alias Inquiry command COMMAREA format

To issue an Alias Inquiry command, pass the following COMMAREA format and values to the command processor.

Table 27. Alias Inquiry command COMMAREA format

Column	Size	Name	Description	Value
1	1	ALI-PASS	Pass-through indicator	4
2	19	ALI-FILLER	Filler	blank
21	8	ALI-COMMAND	Command name	SDIINQA
29	8	ALI-ACCNTNO	Account ID User	Account ID
37	8	ALI-USERID	ID	User ID
45	1	ALI-TBLTYPE	Alias table type	G, O, or P
46	3	ALI-TBLNAME	Alias table name	Table name
49	16	ALI-ALIAS	Alias name	Alias name

ALI-PASS

This field indicates whether the command being submitted is defined to the command processor as a pass-through command or one supported by the command processor. For this command the value must be 4.

ALI-FILLER

Leave this field blank. It is either not required by Expedite/CICS, or the value is supplied by Expedite/CICS and your application cannot override it.

ALI-COMMAND

This field contains a command name of SDIINQA, which identifies this as the Alias Inquiry command. The format is alphanumeric, left-justified, and padded on the right with blanks.

ALI-ACCOUNT

This field contains your account ID. The format is alphanumeric, left-justified, and padded on the right with blanks.

ALI-USERID

This field contains your user ID. The format is alphanumeric, left-justified, and padded on the right with blanks.

ALI-TBLTYPE

This field indicates the type of alias table. The format is a coded value.

This code:	Indicates:
G	A global alias table, accessible by any Information Exchange user
O	An organizational alias table, accessible by any Information Exchange user in the same account.
P	A private alias table, accessible only to its owner.

ALI-TBLNAME

This field contains the 3-character alias table name. The format is alphanumeric, leftjustified, and padded on the right with blanks

ALI-ALIAS

This field contains the alias name to be retrieved.

Alias Inquiry response

Expedite/CICS returns the following information in response to the Alias Inquiry response command. The response length is 73 bytes. This layout will be returned in RSPDATA. For more information about the standard COMMAREA format, see “COMMAREA format for response HI000 or HI001” on page 64.

Table 28. Alias Inquiry response

Column	Size	Name	Description
1	8	COMMAND	Command name
9	8	ACCNTNO	Account ID
17	8	USERID	User ID
25	8	SESSKEY	Session access key
33		EXPAND	Expansion indicator
34	1	TBLTYPE	Alias table type
35	3	TBLNAME	Alias table name
38	16	ALIAS	Alias name
54	20	TRUEID	True user ID

COMMAND

This field contains the value from RETRSPC of the Alias Inquiry command. The format is alpha-numeric, left-justified, and padded on the right with blanks. The value assigned in Expedite/ CICS is SDIINQAR.

ACCNTNO

This field contains your account ID. The format is alphanumeric, left-justified, and padded on

the right with blanks.

USERID

This field contains your user ID. The format is alphanumeric, left-justified, and padded on the right with blanks.

SESSKEY

This field contains the value Information Exchange sends to your system in SESSKEY of the Session Start response. The format is alphanumeric, left-justified, and padded on the right with blanks.

EXPAND

This field contains a value from EXPAND of the Alias Inquiry command.

TBLTYPE

This field contains a value from the Alias Inquiry command.

TBLNAME

This field contains a value from the Alias Inquiry command.

ALIAS

This field contains the value from the Alias Inquiry command.

TRUEID

If the alias or table is unknown, this field contains blanks. Otherwise, it contains the true user ID associated with the alias. If the first character is an I, the user is associated with a different system. In this case, the next 3 characters are the system's identifier.

If the first 4 characters are blanks, the user is on the same Information Exchange system you are on. The fifth through twentieth characters are the account ID (8 characters) and user ID (8 characters).



NOTE: The description of the TRUEID field is the extended Information Exchange address format. If the EXPAND level is less than two, this field is 16 characters long and contains only the account ID and user ID portions of the addressee.

Archive Retrieve pass-through command

Use the Archive Retrieve command to retrieve messages from the archive and place them in your Information Exchange mailbox. This command may be used to retrieve only an archive group; if you want to retrieve a specific message, you must use Information Exchange Administration Services. Archive groups default for each session access key. The Archive Retrieve command is not directly supported by the Expedite/CICS command processor and is sent to Information Exchange using pass-through.

Archive Retrieve command COMMAREA format

To issue an Archive Retrieve command, pass the following COMMAREA format and values to the command processor.

Table 29. Archive Retrieve command COMMAREA format

Column	Size	Name	Description	Value
1	1	PS-PASS	Pass-through indicator	1
2	8	PS-FNAM	File containing the remainder of the command	TSQ name
10	2	PS-FTYP	File type	TS
12	1	PS-DTYPE	Data type	blank
13	8	PS-PAD2	Filler	blank
21	8	PS-COMMAND	Command name	SDIARTV
29	8	PS-ACCNTNO	Account name	Account name
37	8	PS-USERID	User ID	User ID name
45	8	PS-SESSKEY	Session access key	blank



NOTE: The command processor does not provide default values for pass-through commands. You must blank out or type values into all of the fields.

Archive Retrieve command temporary storage queue format

Use the following format to store the remainder of the Archive Retrieve command in the temporary storage queue you specified in the PS-FNAM field in the COMMAREA.

Table 30. Archive Retrieve command temporary storage queue format

Column	Size	Name	Description
1	1	EXPAND	Expansion indicator
2	8	RETRSPC	Response command name
10	8	ARREFID	Archive reference ID

The descriptions of the fields you place in the temporary storage queue are:

EXPAND

This field contains a command expansion-level indicator which must be 1. Invalid values default to blank.

RETRSPC

The value from this field is placed in the first 8 characters of the Archive Retrieve response returned to your user ID. The format is alphanumeric, left-justified, and padded on the right with blanks.

ARREFID

This field specifies the archive reference identifier of the messages you want to retrieve from short-term archive storage. After you have issued the Archive Retrieve command, Information Exchange places the archived messages in your mailbox. To receive the messages, use the Receive Message command (SDIRCVM). The format is alphanumeric, left-justified, and padded on the right with blanks.

Archive Retrieve response

Expedite/CICS returns the following information in response to the Archive Retrieve command. The response length is 38 bytes. This layout will be returned in RSPQOUT; for more information about pass-through COMMAREA format, see “COMMAREA format for pass-through” on page 64.

Table 31. Archive Retrieve command response

Column	Size	Name	Description
1	8	COMMAND	Command name
9	8	ACCNTNO	Account ID
17	8	USERID	User ID
25	8	SESSKEY	Session access key
33	1	EXPAND	Expansion indicator
34	5	RETVCNT	Number of archived messages retrieved.

The descriptions of the fields returned to you in the response are:

COMMAND

This field contains the value from the RETRSPC field of the previously sent Archive Retrieve (SDIARTV) command. The format is alphanumeric, left-justified, and padded on the right with blanks.

ACCNTNO

This field contains an account ID and, along with the USERID field, serves to identify the user. The format is alphanumeric, left-justified, and padded on the right with blanks.

USERID

Archive Retrieve pass-through command

This field contains a user ID and, along with the ACCNTNO field, serves to identify the user. The format is alphanumeric, left-justified, and padded on the right with blanks.

SESSKEY

This field contains the value sent to your system in the SESSKEY field of the Session Start response. The format is alphanumeric, left-justified, and padded on the right with blanks.

EXPAND

This field contains the value from the EXPAND field of the Archive Retrieve command.

RETVCNT

This field contains the number of archived message groups retrieved by the Archive Retrieve command and sent to your Information Exchange mailbox. If the value is zero, either an unknown archive reference was used in the Archive Retrieve command, or all the messages from that archive set have already been retrieved and are still in the mailbox. The format is numeric, right-justified, and padded on the left with zeros.

Audit Retrieve command

Use the Audit Retrieve command to download the contents of your audit file to your Information Exchange mailbox in the form of a message group. You can select the records you want to see by specifying the from date, to date, status, and record type fields. After you issue the Audit Retrieve command, issue the Receive Message command to receive the information from your mailbox. The data is placed in your mailbox from account *SYSTEM*, user ID *AUDITS*, with a message class of #SAUDIT. In most cases, the response will be in your mailbox almost immediately but, depending on the amount of data being retrieved, it may take some time.

The Display Application provides a Batch Receive panel that can be used to write the audit response to a batch data set. A sample batch program is provided to format the audit response. You may choose to revise the sample program to run as a CICS application or to generate different reports. For more information, see Appendix B, “Sample Programs.”

The copybook for this command is EXPAUDR.

Audit Retrieve command COMMAREA format

To issue an Audit Retrieve command, pass the following COMMAREA format and values to the command processor.

Table 32. Archive Retrieve command COMMAREA format

Column	Size	Name	Description	Value
1	1	AUC-PASS	Pass-through indicator	Zero
2	19	AUC-FILR	Filler	blank
21	8	AUC-COMMAND	Command name	SDIAUDR
29	8	AUC-ACCNTNO	User's account	Account name
37	8	AUC-USERID	User ID	User ID name
45	8	AUC-SESSKEY	Session access key	blank
53	1	AUC-EXPAND	Expansion indicator	1 or 2
54	8	AUC-RETRSPC	Response name	blank
62	1	AUC-RECTYPES	Type of records	S, R, or B
63	8	AUC-ALTUSRID	Alternate user ID	
71	20	AUC-TRADPART	Trading Partner	
91	7	AUC-DATEFROM	From date	
98	7	AUC-DATETO	date	
105	8	AUC-MSGUCLS	User message class	
113	1	AUC-STATUS	Status selection	blank, U, P, or D
114	1	AUC-TIMEZONE	Time zone for dates	L or G
115	3	AUC-MAXMSGSZ	Maximum message length	000 - 999

This value:	Means:
>blank<	Expedite/CICS supplies the value for the field. You can use the default in your application, or your application can override it.
blank	The field value is either not required or is supplied by Expedite/CICS and your application cannot override it

The descriptions of the fields you place in the COMMAREA are:

AUC-PASS

This field indicates whether the command being submitted is defined to the command processor as a pass-through command or one supported by the command processor. For the Audit Retrieve command, the value must be zero.

AUC-FILR

This field contains blanks.

AUC-COMMAND

This field must contain SDIAUDR, which identifies this as the Audit Retrieve command. The format is alphanumeric, left-justified, and padded on the right with blanks.

AUC-ACCNTNO

This field, along with the USERID field, identifies the user. The format is alphanumeric, leftjustified, and padded on the right with blanks.

AUC-USERID

This field, along with the ACCNTNO field, identifies the user. The format is alphanumeric, left-justified, and padded on the right with blanks.

AUC-SESSKEY

Leave this field blank. It is either not required by Expedite/CICS, or the value is supplied by Expedite/CICS and your application cannot override it.

AUC-EXPAND

This field contains an expansion-level indicator; invalid values default to 1.

This value:	Indicates:
1	Do not include extended timing fields in the audit record.
2	Include extended timing fields in the audit record.

AUC-RETRSPC

Leave this field blank. It is either not required by Expedite/CICS, or the value is supplied by Expedite/CICS and your application cannot override it.

AUC-RECTYPES

This field specifies the type of message records that will be returned. The format is a coded value, which may be any one of the following:

This code:	Indicates this message:
S	That has been sent by the user.
R	That are receivable, have already been received, or were purged before.
B	Both sent and received by the user.

AUC-ALTUSRID

This field is to be used by service administrators only. Input by other users will be ignored. If you leave the field blank, Information Exchange extracts only your own audit records. To extract audit records for another user within the same account, enter that user's user ID. To extract audit records for all users in the account, enter a question mark. If you are not authorized to extract other users' audit records, the default of blank is applied.

AUC-TRADPART

If you want an audit trail for only one user, enter that user's user ID in this field; otherwise, leave the field blank.

AUC-DATEFROM

Information Exchange extracts only audit records for messages sent on or after the date you enter in this field. Enter the date as **CYYMMDD**, where **C** is the century (0 = 1900, 1 = 2000), **YY** is the low-order year digits, **MM** is the month, and **DD** is the day of the month. For example, 0940502 represents May 2, 1994. The default is 0500101 (January 1, 1950). If a year prior to 1950 is entered, or if no date is entered, a warning message will be generated and the default will be provided by Information Exchange.

AUC-DATETO

Information Exchange extracts only audit records representing messages sent on or before the date you enter in this field. Enter the date as **CYYMMDD**, where **C** is the century (0 = 1900, 1 = 2000), **YY** is the low-order year digits, **MM** is the month, and **DD** is the day of the month. For example, 1010502 represents May 2, 2001. The default is 1991231 (December 31, 2099). If no date is entered, the default is provided by Information Exchange.

AUC-MSGUCLS

Fill in the user message class of the messages you want to select. You may use a question mark to substitute for any digit, in any position. The field is left-justified, and padded on the right with blanks.

AUC-STATUS

This field enables you to select only messages with a given status. The format is a coded value, which may be any one of the following:

This value:	Indicates:
blank	All messages will be selected, regardless of status.
U	Only undelivered messages will be selected.

This value:	Indicates:
P	Only purged messages will be selected.
D	Only messages that have been delivered will be selected.

AUC-TIMEZONE

This field indicates the time zone for the dates in the DATEFROM and DATETO fields. Enter either L (for your local time zone) or G (for Greenwich mean time). L is the default.

AUC-MAXMSGSZ

This field is used to allow checkpoint-level recovery to take commit points during the receiving of the message group that Information Exchange builds. Indicate the size of the biggest message to be created in the message group. The value must be numeric. If the field contains zero or any non-numeric characters, Information Exchange creates a single message in the message group.

The value in this field is multiplied by 1000 to obtain the individual message size.

Audit Retrieve response

Because Audit Retrieve is a response-oriented command, the Expedite/CICS command processor returns the following response as an overlay of the EXPCRSR COMMAREA. The response length is 42 bytes. For more information, see “COMMAREA format for response HI000 or HI001” on page 64.

Table 33. Audit Retrieve response

Column	Size	Name	Description	Value
1	5	AUR-MSGNUM	Message number	HI001 or HIxxx
6	2	AUR-MSGSVC	Severity code	Severity code
8	8	AUR-COMMAND	Response command	SDIAUDRR
16	8	AUR-ACCNTNO	Account name	Account ID
24	8	AUR-USERID	User name	User ID
32	8	AUR-SESSKEY	Session access key	
40	1	AUR-EXPAND	Expansion	blank, 1, or 2
41	2	AUR-RETCODE	Response code	

The response field descriptions are provided below. The audit record format layout of the audit records returned and placed in the Information Exchange mailbox is provided in “Audit record formats” on page 139.

AUR-MSGNUM

This field contains a message number that indicates the success of the Audit Retrieve command:

- HI001** The Audit Retrieve command completed successfully or returned an SDIERR response beginning in column eight (refer to the SDIERR copybook for the command overlay).

HIxxx The data sent in the Audit Retrieve command contained an error.

AUR-MSG SVC

This field contains a code that indicates the severity of the message returned in the AURMSGNUM field.

AUR-COMMAND

This field contains SDIAUDRR, which indicates the response is from the Audit Retrieve command.

AUR-ACCNTNO

This field contains your account ID.

AUR-USERID

This field contains your user ID.

AUR-SESSKEY

This field contains your session access key from the Session Start response.

AUR-EXPAND

This field contains the value from the EXPAND field of the Audit Retrieve command.

AUR-RET CODE

If this field contains a value other than 00, one or more errors occurred during processing, and this is the maximum error-message severity code encountered. Request your Information Exchange error messages to discover the errors. If the value is less than 08, the audit records will be placed in your Information Exchange mailbox. This may take a long time, depending on the number of records to be processed, and the work load on the system.

Browse Library Member

The Browse Library Member command enables you to receive the text of a library member. The library member will be in the temporary storage queue specified in the command upon return from the Expedite/CICS command processor.

The copybook for this command is EXPLBRW.

Table 34. Browse Library Member command

Column	Size	Name	Description	Value
1	1	LBW-PASS	Pass-through indicator	4
2	8	LBW-TSQNAME	TSQ name	Queue name
10	11	FILLER		
21	8	LBW-COMMAND	Command name	SDILBRW
29	8	LBW-ACCOUNT	User's Account ID	Account name
37	8	LBW-USERID	User's User ID	User ID
45	8	LBW-OWNER	Library owning account ID	Account ID
53	8	LBW-LIBNAME	Library name	Library name
61	8	LBW-MEMBER	Member name	Member name
69	5	LBW-ITEM-LENGTH	Item text length	0001-32000
73	4	LBW-NO-OF-ITEMS	Number of items	001-999

LBW-PASS

Indicates if the command is defined to the command processor as a pass-through command or one supported by the command processor. The value must be 4.

LBW-TSQNAME

This field identifies the temporary storage queue file name that will contain the data upon successful return from the command processor. Text returned will begin in item 2.

LBW-COMMAND

This field contains the command name of SDILBRW, which identifies this as the Browse Library Member command.

LBW-ACCOUNT

This field contains your account ID. The format is alphanumeric, left-justified, and padded on the right with blanks.

LBW-USERID

This field contains your user ID. The format is alphanumeric, left-justified, and padded on the right with blanks.

LBW-OWNER

This field identifies the owner of the library **LIBNAME** specified. The default value is your account ID. The format is alphanumeric, left-justified, and padded on the right with blanks.

LBW-LIBNAME

This field contains the name of the library that contains the member you want to browse. The format is alphanumeric, left-justified, and padded on the right with blanks.

LBW-MEMBER

This field contains the name of the member you want to browse. The format is alphanumeric, left-justified, and padded on the right with blanks.

LBW-ITEM-LENGTH

This field contains the maximum length of text to return. The format is numeric, right-justified, and padded on the left with zeros. Expedite/CICS will use this value to reblock data received from Information Exchange to your temporary storage queue.

LBW-NO-OF-ITEMS

This field contains the number of items to return. If this value, multiplied by the value in LBW-ITEM-LENGTH, exceeds 9999, the number of bytes returned from Information Exchange in one transmission is 9999.

Browse Library Member response

Expedite/CICS returns the standard Expedite/CICS response to the user program, using the EXPCRSP format. For information about the response COMMAREA format, see “Command processor responses” on page 63.

This value:	Indicates:
HI000	The command completed successfully; there is more data to retrieve. To retrieve the additional data, reissue the command using the same TSQ name. Expedite/CICS will use the information in Item 1 to retrieve the data and will append it to the item(s) already retrieved.
HI675	The command completed successfully; there is no more library member text to retrieve.
HIxxx	The data sent to the command processor contained an error. For a list of error messages and recommended actions, see <i>Expedite/CICS Messages</i> .



NOTE:

1. Each time you issue the Browse Library Member command, you can retrieve only as many library items as can be contained in your specified data transmission size.
2. Item 1 in the TSQ contains the next locator value or blanks. If subsequent invocations of the command are required to get more data, Expedite/CICS uses Item 1 of the queue to determine where to continue. Additional data retrieved is appended to the same queue.

Cancel pass-through command

To cancel a request to send data to Information Exchange, use the Cancel command. The Cancel command is not directly supported by the Expedite/CICS command processor but is sent to Information Exchange using pass-through. The Cancel command does not produce a response, but you may request a mailbox response in the command. Any command errors will produce a system error in your message mailbox.

Cancel command COMMAREA format

To issue a Cancel command, pass the following COMMAREA values to the command processor.

Table 35. Browse Library Member command.

Column	Size	Name	Description	Value
1	1	PS-PASS	Pass-through indicator	1
2	8	PS-FNAM	File containing the remainder of the command	TSQ name
10	2	PS-FTYP	File type	TS
12	1	PS-DTYPE	Data type	blank
13	8	PS-PAD2	Filler	blank
21	8	PS-COMMAND	Command name	SDICNCL
29	8	PS-ACCNTNO	Account name	Account name
37	8	PS-USERID	User ID	User ID name
45	8	PS-SESSKEY	Session access key	blank

Table 35. Cancel command COMMAREA format



NOTE: The command processor does not provide default values for pass-through commands. You must blank out or type values into all fields.

Cancel command temporary storage queue format

Use the following format to store the remainder of the Cancel command in the temporary storage queue you specified in the PS-FNAM field in the COMMAREA.

Table 36. Cancel command temporary storage queue format

Column	Size	Name	Description
1	8	DESTACCT	Destination account ID
9	8	DESTUID	Destination user ID
17	1	DESTTYPE	Destination type
18	1	MSGCLASS	Message delivery class

Table 36. Cancel command temporary storage queue format

Column	Size	Name	Description
19	8	MSGNAME	Message name
27	5	MSGSEQN	Message sequence number
32	8	MSGUCLS	User message classification
40	6	SUBDSTA	Submit start date
46	6	SUBTSTA	Submit start time
52	6	SUBDEND	Submit end date
58	6	SUBTEND	Submit end time
64	1	MSGTZONE	Time and date zone
65	1	MSGRCPTS	Acknowledgment request
66	1	EXPAND	Expansion indicator
67	1	DTBLTYP	Alias table type for DESTACCT and DESTUID
68	3	DTBLID	Alias table ID for DESTACCT and DESTUID
71	1	SUBCSTA	Submit start date century (C)
72	1	SUBCEND	Submit end date century (C)

The descriptions of the fields you place in the temporary storage queue are:

DESTACCT

This field, along with the DESTUID and DESTTYPE fields, defines the destinations of the messages to be canceled. The format is alphanumeric, left-justified, and padded on the right with blanks. This field contains either a destination account identification (if DESTTYPE contains D) or the name of a list (if DESTTYPE contains I). This is a required field.

DESTUID

If the DESTTYPE field contains D, this field contains the destination user ID. The format is alphanumeric, left-justified, and padded on the right with blanks. If the DESTTYPE contains I, this field is ignored.

DESTTYPE

The value in this field determines the type of reference in the DESTACCT and DESTUID fields. This is a required field.

This value:

Indicates:

D

DESTACCT and DESTUID name a single destination user.

L

DESTACCT is the name of a distribution list.

MSGCLASS

The value in this field identifies the class of delivery service for messages that are to be canceled. This is a required field.

This value:	Indicates:
blank	Normal priority
P	High priority

MSGNAME

If this field is not blank, it must match the message name on the first or only message of any group that is to be canceled. This is an optional field. The format is alphanumeric, left-justified, and padded on the right with blanks.

MSGSEQN

If this field is not blank, it must match the input message sequence number on the first or only message of any group that is to be canceled. This is an optional field. The format is alphanumeric, left-justified, and padded on the right with blanks.

MSGUCLS

If this field is not blank, it must match the user classification field on the first or only message of any group that is to be canceled. This is an optional field. The format is alphanumeric, left-justified, and padded on the right with blanks.

SUBDSTA

If not blank, this field contains a date that specifies the start date of a time range. In order for a message group to qualify for cancellation, the submit time of the first or only message of a group must fall within this time range. The SUBTSTA field specifies the start time of this time range. The SUBDEND field specifies the end date of this time range, and the SUBTEND field specifies the end time of this time range. If blank, the value defaults to 000102. The format is numeric (YYMMDD), right-justified, and padded on the left with zeros.

SUBTSTA

This field contains a time that specifies the start time of a time range in which the submit time of the first or only message of a group to be canceled must fall. If blank, the value defaults to 000000. The format is numeric (HHMMSS), right-justified, and padded on the left with zeros.

SUBDEND

This field contains a date that specifies the end date of a time range in which the submit time of the first or only message of a group to be canceled must fall. If blank, this field defaults to 420916. The format is numeric (YYMMDD), right-justified, and padded on the left with zeros.

SUBTEND

This field contains a time that specifies the end time of a time range in which the submit time of the first or only message of a group to be canceled must fall. If blank, this field defaults to 240000. The format is numeric (HHMMSS), right-justified, and padded on the left with zeros.

MSGTZONE

This field indicates the reference time zone for SUBDSTA, SUBTSTA, SUBDEND, and SUBTEND fields.

This value:	Indicates:
L	Date and time are the sender's local time as stated in the Session Start command
G	Date and time are referenced to Greenwich mean time.

MSGRCPTS

This field is used to request Information Exchange to send one of two types of acknowledgment message to your user ID, regarding cancellation of a message group. Both types of acknowledgment are receipt acknowledgments that are created and queued to your user ID each time Information Exchange cancels a message group. The first type contains only the message-header information about the first or only message in the canceled message group. The second type contains the header information and the message text of the first or only message in the canceled message group.

The values of this field and their meanings are:

This value:	Requests:
blank	No receipt acknowledgment.
H	Only header information in the acknowledgments.
T	Both header and text information in the acknowledgments.

This is an optional field.

EXPAND

This field contains a command expansion-level indicator that must be 1 or 2. An expansionlevel indicator of 2 is used to support the new century indicator fields. Invalid values default to 1.

DTBLTYP

This field identifies the table type of an alias table if DESTTYPE is D. Combined with DTBLID, this field uniquely defines the alias table in which to resolve the alias name created by combining the DES TACCT and DESTUID fields. If you are sending to an alias, enter the alias table type (G, O, or P) in this field. If you are not using an alias table, leave this field blank.

DTBLID

This field identifies the table name of an alias table if DESTTYPE is D. Combined with DTBLTYP, this field uniquely defines the alias table in which to resolve the alias name created by combining the DESTACCT and DESTUID fields. The format is alphanumeric, left-justified, and padded on the right with blanks. If you are using an alias table, enter its name in this field. If you are not using an alias table, leave this field blank.

SUBCSTA

This field is valid only when the EXPAND field is 2. This field enables you to select the century for the submit start date field, and is also referred to as C. A C of 0 indicates a 19xx year; a C of 1 indicates a 20xx year. The default is 0 (19xx year).

SUBCEND

This field is valid only when the EXPAND field is 2. This field enables you to select the century for the submit end date field, and is also referred to as C. A C of 0 indicates a 19xx year; a C of 1 indicates a 20xx year. The default is 1 (20xx year).

Cancel command response

Expedite/CICS returns the standard Expedite/CICS response to the user program, using the EXPCRSP format. For information about the response COMMAREA format, see “Command processor responses” on page 63.

This value:	Requests:
HI000	The command was processed successfully. A cancel request is processed asynchronously.
HI001	A severe error occurred, indicated by SDIERR. The Information Exchange response is placed in the RSPDATA data field of the response COMMAREA. Your application should inspect this Information Exchange response to determine what action, if any, should be taken. For more information, see “SDIERR messages” on page 66.
HIxxx	The data sent to the command processor contained an error. For a list of error messages and recommended actions, see Expedite/CICS Messages.



NOTE: Information Exchange system error messages associated with this command are placed in the user’s mailbox from *SYSTEM* *ERRMSG*.

Define Alias command

This command defines a new alias or redefines an existing alias. You put aliases in an alias table and use them in place of a user's Information Exchange address. There are 36 bytes for every alias to be defined.

This is a non-response command, meaning that Information Exchange does not provide immediate feedback indicating if the command worked correctly. To determine whether or not the command executed correctly within Information Exchange, you must either manually check the alias table for the entry, using Information Exchange Administration Services, or use the alias inquiry command to check for the alias. The length of time it takes the Define Alias command to complete depends on Information Exchange activity. In normal periods of activity, the delay is generally only a few seconds.

Define Alias command COMMAREA format

To issue a Define Alias command, pass the following COMMAREA format and values to the command processor.

Table 37. Define Alias command COMMAREA format

Column	Size	Name	Description	Value
1	1	ALS-PASS	Pass-through indicator	4
2	8	ALS-TSQNAME	TSQ name containing Alias entry	
10	11	ALS-FILLER	Filler	
21	8	ALS-COMMAND	Command	SDIDALS
29	8	ALS-ACCTNO	Account ID	Account ID
37	8	ALS-USERID	User ID	User ID
45	1	ALS-TBLTYPE	Alias table type	G, O, or P
46	3	ALS-TBLNAME	Alias table name	Table name
49	1	ALS-TYPECMND	Command type	A,N,D,C, or E
50	1	ALS-AUTHCOD	Update authorization code	G, A, or P

ALS-PASS

This field indicates whether the command being submitted is defined to the command processor as a pass-through command or one supported by the command processor. For this command, the value must be 4.

ALS-TSQNAME

This field defines the Temporary Storage Queue input file name. This file must contain the Alias Entries that identify the alias names to be added to a table. The format is identified in the table below. The length is 36 bytes per Temporary Storage Queue item.

ALS-FILLER

Leave this field blank. It is either not required by Expedite/CICS, or the value is supplied by Expedite/CICS and your application cannot override it.

ALS-COMMAND

This field contains a command name of SDIDALS, which identifies this as the Define Alias command. The format is alphanumeric, left-justified, and padded on the right with blanks.

ALS-ACCNTNO

This field contains your account ID. The format is alphanumeric, left-justified, and padded on the right with blanks.

ALS-USERID

This field contains your user ID. The format is alphanumeric, left-justified, and padded on the right with blanks.

ALS-TBLTYPE

This field contains the type of alias table in which you are working. The format is a coded value.

This code:	Indicates:
G	A global alias table, accessible by any Information Exchange user.
O	An organization table, accessible only by users in the same account.
P	A private alias table, accessible only by its owner.

ALS-TBLNAME

This field contains the 3-character alias table name. The format is alphanumeric, leftjustified, and padded on the right with blanks.

ALS-TYPECMND

This field indicates what is to be done to the alias table.

This code:	Indicates you want to:
A	Add the entries to an existing alias table.
N	Create a new alias table.
D	Delete the entries from an existing alias table.
C	Change the entries in an existing alias table.
E	Erase the entire alias table.

This field indicates who can update the alias table.

This code:	Indicates update authority for:
G	Any Information Exchange user.
A	Any administrator in the account.

This code: **Indicates update authority for:**
P Only the owner of the table.



NOTE: If you create a global table using global update authorization, users outside your account can add or delete table entries pertaining to their own account, but only support personnel can erase the entire table. Other authorization codes for global tables permit the owner or the account service administrator to make all changes, including erasing the table.

Define Alias Entry (temporary storage queue input)

Alias entries must be provided in the temporary storage queue identified in ALS-TSQNAME. Each alias entry must be a separate TSQ item. The definition uses 36 characters. These characters are as illustrated in the following table.

Table 38. Define alias command temporary storage queue format

Column	Size	Name	Description	Value
1	16	ALE-ALIAS-NAME	Alias name	Alias name
17	1	ALE-ALIAS-TBLTYPE	Table type	G, O, P, I, or blank
18	3	ALE-ALIAS-TBLNAME	Table name	Table name
21	16	ALE-ALIAS-NAME-PTR	Alias name or account/ userid	

The descriptions of the fields you place in the temporary storage queue are:

ALE-ALIAS-NAME

This field specifies the alias name being defined in the table.

ALE-ALIAS-TBLTYPE

This field specifies whether the alias is being defined to point to another alias. You can chain up to five aliases. Specify a **G**, **O**, **P**, or **I** to refer to an alias table type. Specify a blank if you are giving the true user ID.

ALE-ALIAS-TBLNAME

This field specifies the table name if the preceding field is **G**, **O**, or **P**. It specifies the system identifier if the preceding field is **I**.

ALE-ALIAS-NAME-PTR

This field specifies the alias name, or the account ID and user ID to whom the alias table entry points.

See **ALS-TBLTYPE** for more information on alias table types.

Define Alias response

Expedite/CICS returns the standard Expedite/CICS response to the user program, using the EXPCRSP format. For information about the response COMMAREA format, see “Command processor responses” on page 63.

This value:	Indicates:
HI000	The command was processed successfully. The define alias command was issued to Information Exchange.
HI001	A severe error occurred, indicated by SDIERR. The Information Exchange response is placed in the RSPDATA data field of the response COMMAREA. Your application should inspect this Information Exchange response to determine what action, if any, should be taken. For more information, see “SDIERR messages” on page 66.
HIxxx	The data sent to the command processor contained an error. For a list of error messages and recommended actions, see Expedite/CICS Messages.



NOTE: Information Exchange system error messages associated with this command are placed in the user’s mailbox from *SYSTEM* *ERRMSG*

Define Library command

This command creates an Information Exchange library.

The copybook for this command is EXPLDEF.

Define Library command COMMAREA format

Table 39. Define Library command COMMAREA format

Column	Size	Name	Description	Value
1	1	LDF-PASS	Pass-through indicator	4
2	19	LDF-FILLER	Filler	blank
21	8	LDF-COMMAND	Command	SDILDEF
29	8	LDF-ACCOUNT	User's Account ID	Account name
37	8	LDF-USERID	User's User ID	User name
45	8	LDF-LIBNAME	Library name	Library name
53	8	LDF-OWNACCT	Owning account ID	Account ID
61	8	LDF-OWNUSRID	Owning user ID	User ID
69	1	LDF-WRITELVL	Library write access level	P, O, G, or L
70	8	LDF-WRITELST	Library write access list	List name or blank.
78	1	LDF-READLVL	Library read access level	P, O, G, or L
79	8	LDF-READLIST	Library read access list	List name or blank
87	1	LDF-IBMACC	IBM access	Y or N
88	1	LDF-ACTION	Add or replace	A or R
89	1	LDF-SEARCH	Searchable indicator	Y or N
90	1	LDF-OWNRESP	Owner responsible for send charges	Y or N
91	79	LDF-LIBDESC	Library description	Description

LDF-PASS

Indicates if the command is defined to the command processor as a pass-through command or one supported by the command processor. The value must be 4.

LDF-FILLER

Leave this field blank. It is either not required by Expedite/CICS, or the value is supplied by Expedite/CICS and your application cannot override it.

LDF-COMMAND

This field contains the command name SDILDEF, which identifies this as the Define Library command. The format is alphanumeric, left-justified, and padded on the right with blanks.

LDF-ACCOUNT

This field contains your account ID. The format is alphanumeric, left-justified, and padded on the right with blanks.

LDF-USERID

This field contains your user ID. The format is alphanumeric, left-justified, and padded on the right with blanks.

LDF-LIBNAME

This field contains the name of the library you want to define. The format is alphanumeric, left-justified, and padded on the right with blanks.

LDF-OWNACCT

This field contains the owning account ID. The format is alphanumeric, left-justified, and padded on the right with blanks. Your account and user ID must be authorized to the owning account and user ID in order for this command to execute successfully in Information Exchange.

LDF-OWNUSRID

This field contains the owning user ID. The format is alphanumeric, left-justified, and padded on the right with blanks.

LDF-WRITELVL

This field contains the authority level for write access to the library. The format is a coded value.

This code:	Indicates write access for:
P	Only the library owner
O	Only users in the same account as the library owner
G	Any user
L	Any user in the list named in the WRITELST field.

LDF-WRITELST

This field contains the name of a permanent distribution list of users who can update the library.

If **LDF-WRITELVL** is **L**, **LDF-WRITELST** must contain a value. Because Information Exchange allows a library to be added before an associated list exists, the value is not validated.

If **LDF-WRITELST** is specified, **LDF-WRITELVL** must be set to **L**.

LDF-READLVL

This field indicates read access authority to the library.

This code:	Indicates read access for:
P	Only the library owner.

This code:	Indicates read access for:
O	Only users in the same account as the library owner.
G	Any user.
L	Any user in the list named in the READLST field.

LDF-READLIST

This field contains the name of a permanent distribution list that details the users who have read access to the library.

If LDF-READLVL is L, LDF-READLIST must contain a value. Because Information Exchange allows a library associated with a list to be added before the list name exists, the value is not validated.

If LDF-READLST is specified, LDF-READLVL must be set to L.

LDF-IBMACC

This field specifies whether Customer Care has access to the library.

This code:	Indicates Customer Care:
<u>Y</u>	Has permission to read the data in the library
N	Does not have permission to read data in the library

LDF-ACTION

The value in this field specifies what action Information Exchange is to take.

This code:	Indicates the library should be:
<u>A</u>	Added if it does not already exist
R	Replaced

LDF-SEARCH

This field specifies whether the library is searchable:

This code:	Indicates :
<u>N</u>	The library is not searchable
Y	The library is searchable.

LDF-OWNRESP

This field specifies if the owner of the library pays library retrieve charges.

This code:	Indicates send-side charges paid for by the:
Y	Library owner
N or <u>blank</u>	Account that issued the retrieve command.

Define Library command

LDF-LIBDESC

This field contains a description of the library; it is not validated.

Define Library response

Expedite/CICS returns the standard Expedite/CICS response to the user program, using the EXPCRSP format. For information about the response COMMAREA format, see “Command processor responses” on page 63.

This value:

HI000

HIxxx

Indicates:

The command completed successfully.

The data sent to the command processor contained an error. For a list of error messages and recommended actions, see *Expedite/CICS Messages*.

Delete Library command

This command deletes a library. If the Force Delete indicator is on, the system deletes all members of the library.

The copybook for this command is EXPLDEL

Table 40. Delete Library command

Column	Size	Name	Description	Value
1	1	LDL-PASS	Pass-through indicator	4
2	19	LDL-FILLER	Filler	
21	8	LDL-COMMAND	Command	SDILDEL
29	8	LDL-ACCOUNT	User's account ID	Account ID
37	8	LDL-USERID	User's user ID	Account ID User ID
45	8	LDL-OWNER	Owning account ID	Account ID
53	8	LDL-LIBNAME	Library name	Library name
61	2	LDL-OPTIONS	Delete option	F or blank

LDL-PASS

Indicates if the command is defined to the command processor as a pass-through command or one supported by the command processor. The value must be 4.

LDL-FILLER

Leave this field blank. It is either not required by Expedite/CICS, or the value is supplied by Expedite/CICS and your application cannot override it.

LDL-COMMAND

This field contains a command name of SDILDEL, which identifies this as the Delete Library command. The format is alphanumeric, left-justified, and padded on the right with blanks.

LDL-ACCOUNT

This field contains your account ID. The format is alphanumeric, left-justified, and padded on the right with blanks.

LDL-USERID

This field contains your user ID. The format is alphanumeric, left-justified, and padded on the right with blanks.

LDL-OWNER

This field contains the identification the owner of the library specified by LIBNAME. The default value is the account to which you belong. The format is alphanumeric, left-justified, and padded on the right with blanks.

LDL-LIBNAME

This field contains the name of the library you want to delete. The format is alphanumeric, left-justified, and padded on the right with blanks.

LDL-OPTIONS

This field contains the delete options that follow:

This code:	Indicates the system should delete the library:
blank	Only if it contains no members
F	Including existing; this is the Force Delete indicator.

Delete Library response

Expedite/CICS returns the standard Expedite/CICS response to the user program, using the EXPCRSP format. For information about the response COMMAREA format, see “Command processor responses” on page 63.

This value:	Indicates:
HI000	The command was processed successfully. A library delete request is processed asynchronously. This response does not necessarily mean that the library has been deleted.
HIxxx	The data sent to the command processor contained an error. For a list of error messages and recommended actions, see Expedite/CICS Messages.



NOTE: As the Delete Library command is processed asynchronously with Information Exchange, if an error is encountered, a system error message will be placed in the user’s mailbox from *SYSTEM* *ERRMSG*.

Delete Library Member command

This command deletes a member from a library. The copybook for this command is EXPLDLM.

Table 41. Retrieve Library Member command

Column	Size	Name	Description	Value
1	1	DLM-PASS	Pass-through indicator	4
2	19	DLM -FILLER	Filler	
21	8	DLM-COMMAND	Command	SDILDLM
29	8	DLM -ACCOUNT	User's account ID	Account ID
37	8	DLM -USERID	User's user ID	User ID
45	8	DLM -OWNER	Owning account ID	Account ID
53	8	DLM -LIBNAME	Library name	Library name
61	2	DLM -MEMBER	Member name	Member name

DLM-PASS

Indicates if the command is defined to the command processor as a pass-through command or one supported by the command processor. The value must be 4.

DLM-FILLER

Leave this field blank. It is either not required by Expedite/CICS, or the value is supplied by Expedite/CICS and your application cannot override it.

DLM-COMMAND

This field contains a command name of SDILDLM, which identifies this as the Delete Library Member command. This command requests the deletion of a member from a library. The format is alphanumeric, left-justified, and padded on the right with blanks.

DLM-ACCOUNT

This field contains your account ID. The format is alphanumeric, left-justified, and padded on the right with blanks.

DLM-USERID

This field contains your user ID. The format is alphanumeric, left-justified, and padded on the right with blanks.

DLM-OWNER

This field identifies the owner of the library specified by LIBNAME. The default value is the account to which you belong. The format is alphanumeric, left-justified, and padded on the right with blanks.

DLM-LIBNAME

This field contains the name of the library from which you want to delete the specified member. The format is alphanumeric, left-justified, and padded on the right with blanks.

DLM-MEMBER

This field contains the name of the member you want to delete. The format is alphanumeric, left-justified, and padded on the right with blanks.

Delete Library Member response

Expedite/CICS returns the standard Expedite/CICS response to the user program, using the EXPCRSP format. For information about the response COMMAREA format, see “Command processor responses” on page 63.

This value:	Indicates:
HI000	The command was processed successfully. A library delete request is processed asynchronously. This response does not necessarily mean that the library member has been deleted.
HIxxx	The data sent to the command processor contained an error. For a list of error messages and recommended actions, see Expedite/CICS Messages.



NOTE: As the Delete Library Member command is processed asynchronously with Information Exchange, if an error is encountered, a system error message will be placed in the user’s mailbox from *SYSTEM* *ERRMSG*.

Library PutMember command

The following layout is used to add a member to a library. You must have update access to the library specified in order for the command to complete successfully in Information Exchange.

The copybook for this command is EXPPUTM.

Table 42. LibraryPutMember command

Column	Size	Name	Description	Value
1	1	PUT-PASS	Pass-through indicator	4
2	8	PUT-FNAME	File name	File name
10	2	PUT-FTYPE	File type	TS, TD, VS
12	1	PUT-DTYPE	Data type	A, B, O
13	8	PUT-FILLER1	Filler	
21	8	PUT-COMMAND	Command	EXPPUTM
29	8	PUT-ACCOUNT	User's account	Account name
37	8	PUT-USERID	User's user ID	User ID
45	8	FILLER	Filler	
53	8	PUT-LIBACCT	Library owning account	Account
61	8	PUT-LIBNAME	Library name	Library name
69	8	PUT-LIBMEMB	Library member	Library member
77	8	PUT-LIBREPL	Replacement option	Replacement option
85	79	PUT-DESC	File description	Free format
164	8	PUT-MSGUCLS	Message user class	Message User Class
172	1	PUT-MSGRCPTS	Message receipts	blank, A, D, E
173	1	PUT-MSGCHRG	Message charge	
174	8	PUT-MSGNAME	Message name	Message name
182	5	PUT-MSGSEQN	Message sequence number	Alphanumeric
187	5	PUT-LRECL	Record length	00001 - 32000
192	4	PUT-RECFM	Record format	Alphanumeric
196	2	PUT-MSGRETN	Undelivered retention	00-1 80

PUT-PASS

Indicates if the command is defined to the command processor as a pass-through command or one supported by the command processor. The value must be 4.

PUT-FNAME

This field identifies the name of the file that is being sent.

PUT-FTYPE

This code: Indicates Information Exchange should create: This field indicates the type of file being sent:

This code:	Indicates Information Exchange should create:
TS	Temporary storage
TD	Transient data
VS	VSAM ESDS

PUT-DTYPE

This field indicates the type of data being sent. EDI data is not supported.

This code:	Indicates Information Exchange should create:
A	CRLF
B	LL
O	Other

PUT-FILLER1

Leave this field blank. Either it is not required by Expedite/CICS, or the value is supplied by Expedite/CICS and your application cannot override it.

PUT-COMMAND

This field contains a command name of EXPPUTM, which identifies this as the Expedite/CICS Put Message command. The format is alphanumeric, left-justified, and padded on the right with blanks.

PUT-ACCOUNT

This field contains your account ID. The format is alphanumeric, left justified, and padded on the right with blanks.

PUT-USERID

This field contains your user ID. The format is alphanumeric, left justified, and padded on the right with blanks.

FILLER

Leave this field blank. Either it is not required by Expedite/CICS, or the value is supplied by Expedite/CICS and your application cannot override it.

PUT-LIBACCT

Specify the owning account name of the library that will contain the data. If this field is blank, it will default to your account.

PUT-LIBNAME

Specify the library name.

PUT-LIBMEMB

Specify the name of the library member that will contain the data.

PUT-LIBREPL

Indicate in this field whether the member you are adding is replacing an existing member with the same name. If you do not specify the replace option and a member with the same name exists, Information Exchange generates an error. This response, from *SYSTEM* *ERRMSG*, will be placed in your mailbox. Expedite/CICS marks the file as sent.

PUT-DESC

This field allows you to describe the file being sent in a 79-byte free-format field. You may place the value here, or in the CDH description field, input from the TSQ.

PUT-MSGUCLS

This field may be used to specify a descriptor for selective message retrieval from the Information Exchange queue. The format is alphanumeric, left-justified, and padded on the right with blanks.

PUT-MSGRCPTS

Specify the type of acknowledgment you want to receive.

This code:	Indicates Information Exchange should create:
blank	No acknowledgements
A	Only purge acknowledgements
D	Only delivery acknowledgments, which are sent to the user when Information Exchange delivers the data to the library.
E	Both purge and delivery acknowledgments.

The following acknowledgment codes are not supported in the Library PutMember command:

- R: Receipt acknowledgments, created and sent to a user when Information Exchange receives a message and reaches the recovery point with the sender.
- B, C, and F: Associated with receipt acknowledgments.

For more information, see “Using acknowledgments with libraries” on page 120.

PUT-MSGCHRG

The value in this field indicates to Information Exchange how the sender wants message charges to be paid; refer to the Information Exchange Interface Programming Guide for details about message charge codes. For a message group, the charge method requested in the first message within the group determines the charge method for the entire group. If the value is blank or zero, it will default to 3. The Information Exchange charge values are listed below.

This code:	Indicates that charges are paid by:
1	The receiver
3	The receiver, if agreed to by the receiver, otherwise, the library owner pays

This code:	Indicates that charges are paid by:
5	The sender, if agreed to by the library owner; otherwise, the receiver pays
6	The sender

PUT-MSGNAME

This field is used in conjunction with PUT-MSGSEQN, in the Message ID column of the Information Exchange Administration Services audit trail. Both fields are included in the audit trail record format. The format is alphanumeric, left-justified, and padded on the right with blanks. This field will default to blank; it is not validated.

PUT-MSGSEQN

This field is used, in conjunction with PUT-MSGNAME, in the Message ID column of the Information Exchange Administration Services audit trail. Both fields are included in the audit trail record format. The format is alphanumeric, left-justified, and padded on the right with blanks. This field will default to blank; it is not validated.

PUT-LRECL

This field indicates the record length, greater than 0, less than 32000. If this field is specified, Expedite/CICS places the record length into the CDH of the message, so that it is formatted with that length when it is viewed. If the record length is not specified, the member will be wrapped at 79 bytes when it is viewed. The option may be specified only with File type O. If this value is specified, then F must be placed in PUT-RECFM.

PUT-RECFM

This field is used to describe the record format; it is not validated. If PUT-LRECL is greater than zero, then F must be placed in this field.

PUT-MSGRETN

This field allows you to specify to Information Exchange how long (up to 180 days) to retain an undelivered file. If you leave this field blank or specify 00, it defaults to the value specified for your system; in the U.S., this is 30 days.

Library PutMember response

Expedite/CICS returns the standard Expedite/CICS response to the user program, using the EXPCRSP format. For information about the response COMMAREA format, see “Command processor responses” on page 63.

This value:	Indicates:
HI000	The command was processed successfully. A Library PutMember request is processed asynchronously. This response does not necessarily mean that the library member has been added.
HIxxx	The data sent to the command processor contained an error. For a list of error messages and recommended actions, see <i>Expedite/CICS Messages</i> .



NOTE:

1. As the Library PutMember command is processed asynchronously with Information Exchange, if an error is encountered, a system error message will be placed in the user's mailbox from *SYSTEM* *ERRMSG*
2. Library PutMember requests are converted into the SDISNDM (Send Message) command

Library Search command

This command returns, to a TSQ specified in the command, a list of library members that meet the search criteria. Items are returned as described under “Library Member List Entry” on page 213. Each item in the TSQ contains one library member item.

The copybook for this command is EXPLSCH.

Table 43. Library Search command

Column	Size	Name	Description	Value
1	1	SCH-PASS	Pass-through indicator	4
2	8	SCH-TSQNAME	Temporary storage queue name	Queue name
10	11	SCH-FILLER	Filler	
21	8	SCH-COMMAND	Command	SDILSCH
29	8	SCH-ACCOUNT	User's account ID	Account ID
37	8	SCH-USERID	User's user ID	User ID
45	8	SCH-SRCHACCT	Account to search	Account ID
53	8	SCH-SRCHLIB	Library to search	Library name
61	1	SCH-SORTSEQ	Sort sequence	A or D
62	4	SCH-LENGTH	Length of search argument string	Length
66	1-n	SCH-SRCHARG	Search argument string	Search argument

SCH-PASS

Indicates if the command is defined to the command processor as a pass-through command or one supported by the command processor. The value must be 4.

SCH-TSQNAME

This field identifies the TSQ file name that will contain the data upon successful completion of the command. The command processor validates this field to ensure it contains a value with no embedded blanks.

SCH-FILLER

Leave this field blank. It is either not required by Expedite/CICS, or the value is supplied by Expedite/CICS and your application cannot override it.

SCH-COMMAND

This field contains a command name of SDILSCH, which identifies this as the Search Library command.

SCH-ACCOUNT

This field contains your account ID. The format is alphanumeric, left-justified, and padded on the right with blanks.

SCH-USERID

This field contains your user ID. The format is alphanumeric, left-justified, and padded on the right with blanks.

SCH-SRCHACCT

This field contains the owning account of the library you want to search. If this field is blank, the value in SCH-ACCOUNT is used.

SCH-SRCHLIB

This field contains the name of the library you want to search.

SCH-SORTSEQ

This field indicates the order in which members are to be returned.

This code:**Indicates :****blank**

No acknowledgements

A

Ascending creation date and time

D

Descending creation date and time.

Any other value indicates that no date and time sort is to be performed.

SCH-LENGTH

This field contains the length of the search arguments; it must be numeric and greater than zero.

SCH-SRCHARG

This field contains the search argument string whose length is specified in SCH-LENGTH. A search argument string is a character string that represents the words to be located and logical relationships to be used (such as or, and, or not). The format is algebraic. A word is delimited by a blank or one of the logical operators shown in Table 44.

Table 44. Search LibraryMembers logical operators.

Logical Operator	Explanation
&	Logical and operator or ! or
Logical or operator (or [or {	Beginning of a logical expression
) or] or }	End of a logical expression
- or -	Use a minus sign or dash to indicate a range operator. If the word on the right of the operator is less than the word on left of the operator, the result is null
*	Word truncation or abbreviation; used with ranges
¬ or ~	Logical not operator

For example, if you specify: (James&¬Jones)|Johns*

You will find members containing the word James and not the word Jones, or words that begin with the 5 letters: Johns.

**NOTE:**

1. A search word may be 2 to 12 characters long; single characters are ignored and words longer than 12 characters are truncated.
2. The word(s) you search for may contain alphanumeric characters plus the following special characters: # % \$ @

During the search, invalid special characters are ignored

3. Words are delimited by a blank
4. When Information Exchange creates a searchable library, it creates a glossary entry for each unique word in the member text. All alphabetic characters are shifted into uppercase. The following words are not placed in the glossary: AN, AT, IF, IN, IT, OF, ON, OR, TO, AND, BUT, NOT, and THE.

Library Search response

Expedite/CICS returns the standard Expedite/CICS response to the user program, using the EXPCRSP format. For information about the response COMMAREA format, see “Command-processor responses” on page 63.

This value:**HI000****HI645****HI675****HIxxx****Indicates :**

The command completed successfully

The TSQ name passed contained no library members

The TSQ name passed contained library members.

The data sent to the command processor contained an error. For a list of error messages and recommended actions, see *Expedite/CICS Messages*.

List Define command

You use distribution lists to communicate with multiple users at one time. Although the Display Application provides a method for defining and automatically uploading temporary distribution lists to Information Exchange, which last for the duration of a session, you might want to create a permanent list that will be maintained on Information Exchange. To do this, follow these steps:

1. Build the distribution list.
2. Place the distribution list in a temporary storage queue.
3. Issue the List Define command.

Before you issue the List Define command, your application must use the session exit to check the session end indicator, as described in “Session Exit” on page 128. If it is on, your application cannot issue the List Define command. If the session end indicator is not on, the List Define command in the COMMAREA is combined with the distribution list entries in the temporary storage queue (specified in the DL-FNAM field) and is passed to Information Exchange. You can have a maximum of 180 distribution list entries in each queue. Each list entry must be on a separate TSQ item.

The copybook for this command is EXPLSTD.

The format of each entry in the distribution list is as follows:

Table 45. List Define command

Column	Size	Name	Description	Value
1	1	DL-ATYPE	Alias table type	Blank, G, I, O, P
2	3	DL-TABLEID	Alias table name	Alias table name
6	8	DL-ACCT	Account name	Account name
14	8	DL-USER	User ID	User ID name

The descriptions of the fields in the distribution list are:

DL-ATYPE

This field contains one of the following codes which indicate whether this is a true Information Exchange address or an alias ID entry.

This code:	This code:
G	An alias-table reference to a global table.
O	An organization (account) alias table.
P	A private table.
I	An intersystem address.
Blank	A reference to a true Information Exchange address..

DL-TABLEID

This field names the alias table to be used to search for the account ID and user ID if DL-ATYPE is G, O, or P. This is the system identifier if DL-ATYPE is I. Leave this field blank if DL-ATYPE is blank.

DL-ACCT

This field specifies the Information Exchange account ID of the desired destination if the value in the **DL-TABLEID** field is I, or blank. If the value in **DL-TABLEID** is **G**, **O**, or **P**, the value in this field is concatenated with the value in the **DL-USER** field to specify the first eight bytes of the 16-character alias name.

DL-USER

This field specifies the Information Exchange user ID of the desired destination if the value in the **DL-TABLEID** field is I, or blank. If the value in **DL-TABLEID** is **G**, **O**, or **P**, the value in this field is concatenated with the value in the **DL-ACCT** field to specify the last 8 bytes of the 16-character alias name.

You may reference only 50 lists at a time during an Information Exchange session. If you try to upload or reference more than 50 lists, you will receive an error message. You may then issue a List Define command to Information Exchange to erase a list that is no longer being used and then resubmit the List Define command to create the new list.

List Define command COMMAREA format

The format and values of the COMMAREA passed between the upload list module and the command processor are:

Table 46. List Define command COMMAREA format

Column	Size	Name	Description	Value
1	1	DL-PASS	Pass-through indicator	Zero
2	8	DL-FNAM	Queue containing list entries	TSQ name
10	2	DL-FTYPE	File type	TS
12	1	DL-DTYPE	Data type	blank
13	8	DL-FILR	Filler	blank
21	8	DL-COMMAND	Command name	SDILSTD
29	8	DL-ACCNTNO	User's account	Account name
37	8	DL-USERID	User ID	User ID name
45	8	DL-SESSKEY	Session access key	blank
53	8	DL-LISTNAME	List name	List name
61	1	DL-TYPECMND	Command type	A, N, D, or E
62	1	DL-LISTTYPE	Type of list	A, G, P, or blank
63	1	DL-EXPAND	Expansion indicator	1
64	4	DL-LSTSIZE	Number of destination IDs	Number of list entries

This value:	Means:
>blank<	Expedite/CICS supplies the field value. You can use the default value in your application, or your application can override it
blank	The field is either not required by Expedite/CICS, or the value is supplied by Expedite/CICS and your application cannot override it.

The descriptions of the fields you place in the COMMAREA are:

DL-PASS

This field indicates whether the command being submitted is defined to the command processor as a pass-through command or one supported by the command processor. For the List Define command, the value must be zero.

DL-FNAM

This field identifies the name of the temporary storage queue that contains the distribution list entries. You can have a maximum of 180 distribution list entries in each queue.

DL-FTYPE

This field identifies the type of file being sent. For the List Define command, the value must be TS.

DL-DTYPE

Leave this field blank. It is either not required by Expedite/CICS, or the value is supplied by Expedite/CICS and your application cannot override it.

DL-FILR

Leave this field blank. It is either not required by Expedite/CICS, or the value is supplied by Expedite/CICS and your application cannot override it.

DL-COMMAND

This field must contain SDILSTD, which identifies this as a List Define command. The format is alphanumeric, left-justified, and padded on the right with blanks.

DL-ACCNTNO

This field contains an account ID and, along with the USERID field, serves to identify the user. The format is alphanumeric, left-justified, and padded on the right with blanks.

DL-USERID

This field contains a user ID and, along with the ACCNTNO field, serves to identify the user. The format is alphanumeric, left-justified, and padded on the right with blanks.

DL-SESSKEY

Leave this field blank. It is either not required by Expedite/CICS, or the value is supplied by Expedite/CICS and your application cannot override it.

DL-LISTNAME

This field contains the name by which this user ID refers to this list in Send Message (SDISNDM) and Receive Message (SDIRCVM) commands. Lists are kept unique to a particular user ID when they are recorded in the Information Exchange database for the duration of the session. The format is alphanumeric, left-justified, and padded on the right with blanks.

DL-TYPECMND

You must specify **N** in the **DL-TYPECMND** field for the first list entries to be uploaded. To upload additional entries, you must specify **A** in the **DL-TYPECMND** for each queue passed. The number of distribution list IDs must be placed in the **DL-LSTSIZE** field.

This field indicates the type of operation to be performed on the list.

This code:	Indicates you want to:
A	Add temporary storage queue entries to the list. If the list name is not known, the results will be the same as when using option N .
N	Create a new list or replace a list with the same name.
D	Delete destinations contained in the temporary storage queue from the list. If all names are deleted, the results will be the same as when using option E .
E	Erase entire list.

DL-LISTTYPE

This field indicates the list type.

This code:	Indicates the list is:
blank	A user's temporary list
P	A user's permanent list.
A	An account-level list; this type also is permanent, but is addressable by all users within the account
G	An account-level list that includes user grouping. It is a permanent list addressable by all users within the account and may contain users only within the same account. For more information about group lists, see the <i>Information Exchange Interface Programming Guide</i> .

DL-EXPAND

This field contains a command expansion-level indicator that must be 1. Invalid values default to blank.

DL-LSTSIZE

This field contains the number of destination IDs in the temporary storage queue if **DL-TYPECMND** is **A**, **N**, or **D**. The format is alphanumeric, right justified, and padded on the left with zeros.

List Define response

Expedite/CICS returns the standard Expedite/CICS response to the user program, using the EXPCRSP format. For information about the response COMMAREA format, see “Command processor responses” on page 63.

This value:	Indicates:
HI000	The List Define executed successfully. No response is stored.
HI001	An error may have occurred, indicated by SDIERR. The Information Exchange response is placed in the RSPDATA data field of the response COMMAREA. Your application should inspect this Information Exchange response to determine what action, if any, should be taken. For more information, see “SDIERR messages” on page 66.
HIxxx	The data sent to the command processor has an error. See <i>Expedite/CICS Messages</i> for a list of error messages and recommended corrective actions.
	Possible errors include: HI421 Session profile does not exist



NOTE: Information Exchange system error messages associated with this command are placed in the user’s mailbox from *SYSTEM* *ERRMSG*.

List Library command

This command returns a list of all account libraries or a list of libraries for which you have either read or write access, according to the value specified in the **LST-SELECT** field. The list of libraries will exist in the TSQ specified in the command upon return from the Expedite/CICS command processor. Each item in the queue contains one library entry, which is formatted in the Library Entry Item Structure, described in “Library Entry Item Structure” on page 209.

The copybook for this command is EXPLLST.

Table 47. List Library command

Column	Size	Name	Description	Value
1	1	LST-PASS	Pass-through indicator	4
2	8	LST-TSQNAME	TSQ name	Queue name
10	11	LST-FILLER	Filler	
21	8	LST-COMMAND	Command name	SDILLST
29	8	LST-ACCOUNT	User's account ID	User ID
37	8	LST-USERID	User's user ID	User ID
45	8	LST-LIBACCT	Account to search	Account
53	1	LST-SELECT	Library list selection	A or C
54	1	LST-AUTHSEL	Authority selection	R or W

LST-PASS

Indicates if the command is defined to the command processor as a pass-through command or one supported by the command processor. The value must be **4**.

LST-TSQNAME

This field identifies the temporary storage queue file name. Upon successful return from the command processor, data is stored in this file in the format defined in the Library entry item structure for this command (see Table 48 on page 209). The data starts in item 2 of the TSQ. This field will be validated to ensure it is not blank.

LST-FILLER

Leave this field blank. It is either not required by Expedite/CICS, or the value is supplied by Expedite/CICS and your application cannot override it.

LST-COMMAND

This field contains a command name of SDILLST, which identifies this as the List Libraries command.

LST-ACCOUNT

This field contains your account ID. The format is alphanumeric, left-justified, and padded on the right with blanks.

LST-USERID

This field contains your user ID. The format is alphanumeric, left-justified, and padded on the right with blanks.

LST-LIBACCT

This field contains the account for which libraries are to be listed. If you leave this field blank, the system lists all libraries in the accounts to which you have access.

LST-SELECT

This field contains the type of list required.

This code:	Specifies
A	A list of libraries accessible from this account.
C	A complete list of all libraries.

LST-AUTHSEL

This field contains a value that selects only those libraries with a given access authority. If the value in LST-SELECT is C, this field is ignored.

This code:	Selects only those libraries for which:
R	You have read access
W	You have update access

List Library response

Expedite/CICS returns the standard Expedite/CICS response to the user program, using the EXPCRSP format. For information about the response COMMAREA format, see “Command processor responses” on page 63.

This value:	Indicates:
HI000	The command completed successfully; there is more data to retrieve. To retrieve the additional data, reissue the command using the same TSQ name. Expedite/CICS will use the information in Item 1 to retrieve the data and will append it to the item(s) already retrieved.
HI675	The command completed successfully; there are no more library items to retrieve.
HIxxx	The data sent to the command processor contained an error. For a list of error messages and recommended actions, see Expedite/CICS Messages.

**NOTE:**

1. Each time you issue the List Library command, you can retrieve only as many library items as can be contained in your specified data transmission size.
2. Item 1 in the TSQ contains the next locator value or blanks. If subsequent invocations of the command are required to get more data, Expedite/CICS will use Item 1 of the queue to determine where to continue. Additional data retrieved will be appended to the same queue.

Library Entry Item Structure

The Library Entry Item Structure is 174 bytes long and represents one item that will exist in the TSQ specified for the SDILLST command.

If a user who does not have access to a library requests library information, the system returns only the **LIBNAME**, **LIBACCT**, **LIBUSER**, and **LIBTITLE** fields. Information Exchange returns the remaining fields blank.

The copybook for this data layout is EXPLEIS.

Table 48. Library entry item structure

Column	Size	Name	Description
1	8	EIS-LIBNAME	Library name
9	8	EIS-LIBACCT	Library owner account ID
17	8	EIS-LIBUSER	Library owner user ID
25	6	EIS-CDATE	Library creation date
31	6	EIS-CTIME	Library creation time
37	8	EIS-ULIBACCT	Library update account
45	8	EIS-ULIBUSER	Library update user ID
53	6	EIS-UPDATE	Library update date
59	6	EIS-UTIME	Library update time
65	10	EIS-MEMCOUNT	Number of members
75	1	EIS-WRITETYP	Write authority level
76	8	EIS-WRITELST	Write list
84	1	EIS-READTYP	Read authority level
85	8	EIS-READLIST	Read list
93	1	EIS-SEARCH	Searchable indicator
94	1	EIS-OWNRESP	Owner responsible for retrieve
95	79	EIS-LIBTITLE	Library descriptive title

EIS-LIBNAME

This field contains the name of the library to which the statistics and information pertain. The format is alphanumeric, left-justified, and padded on the right with blanks.

EIS-LIBACCT

This field contains the library owner account ID. The format is alphanumeric, left-justified, and padded on the right with blanks.

EIS-LIBUSER

This field contains the library owner user ID. The format is alphanumeric, left-justified, and padded on the right with blanks.

EIS-CDATE

This field contains the date, YYMMDD, the library was redefined. Information Exchange corrects the date to that of your local time zone.

EIS-CTIME

This field contains the time, HHMMSS, the library was redefined. Information Exchange corrects the time to that of your local time zone. The system defaults to your local time zone.

EIS-ULIBACCT

This field contains the account ID of the user who last redefined this library.

EIS-ULIBUSER

This field contains the user ID of the user who last redefined this library.

EIS-UDATE

This field contains the date, YYMMDD, the library was defined. Information Exchange corrects the date to that of your local time zone.

EIS-UTIME

This field contains the time, HHMMSS, the library was defined. Information Exchange corrects the time to that of your local time zone.

EIS-MEMCOUNT

This field contains the number of members in the library.

EIS-WRITETYP

This field contains the authority type for update access to the library.

This value: **Indicates update access for:**

P	Only the library owner.
O	Only users in the same account as the library owner.
G	Any user.
L	Any user in the list named in the EIS-WRITELST field.

List Library command

EIS-WRITELST

This field names a permanent distribution list of users who can update the library.

EIS-READTYP

This field contains the authority type for read access to the library.

This value:	Indicates read access for:
P	Only the library owner.
O	Only users in the same account as the library owner.
G	Any user.
L	Any user in the list named in the EIS-READLST field.

EIS-READLIST

This field names a permanent distribution list of users who have read access to the library.

EIS-SEARCH

This field indicates whether the library is searchable:

This code:	Indicates:
N	The library is not searchable.
Y	The library is searchable.

EIS-OWNRESP

This field contains a value that indicates whether you want to be responsible for the charges associated with Library Retrieve commands.

This code:	Indicates send-side charges will be paid by:
Y	You.
N	The account that issues the retrieve command.

EIS-LIBDESC

This field contains a description of the library.

List Library Member command

This command provides a list of library members or statistics for a selected library. The list of library members will exist in the TSQ specified in the command upon return from the Expedite/ CICS command processor. Each item in the queue contains one library member entry, which is formatted in the Library Member List Entry format, described in “Library Member List Entry” on page 213.

The copybook for this command is EXPLMBR.

Table 49. List Library Member command

Column	Size	Name	Description	Value
1	1	MBR-PASS	Pass-through indicator	4
2	8	MBR-TSQNAME	TSQ name	Queue name
10	11	MBR-FILLER	Filler	
21	8	MBR-COMMAND	Command e	SDILMBR
29	8	MBR-ACCOUNT	User's account ID	Account ID
37	8	MBR-USERID	User's user ID	User ID
45	8	MBR-OWNER	Owning account ID	Account ID
53	8	MBR-LIBNAME	Library name	Library name

MBR-PASS

Indicates if the command is defined to the command processor as a pass-through command or one supported by the command processor. The value must be 4.

MBR-TSQNAME

This field identifies the TSQ file name that will contain the data upon successful completion of the command. Data starts in Item 2 of the TSQ.

MBR-FILLER

Leave this field blank. It is either not required by Expedite/CICS, or the value is supplied by Expedite/CICS and your application cannot override it.

MBR-COMMAND

This field contains a command name of SDILMBR, which identifies this as a List Library Members command.

MBR-ACCOUNT

This field contains your account ID. The format is alphanumeric, left-justified, and padded on the right with blanks.

MBR-USERID

This field contains your user ID. The format is alphanumeric, left-justified, and padded on the right with blanks.

MBR-OWNER

This field identifies the owner of the library. The default value is the account to which you belong. The format is alphanumeric, left-justified, and padded on the right with blanks. If this field is blank, the default value of MBR-ACCOUNT is assigned.

MBR-LIBNAME

This field specifies the name of the library from which you want to list the members. The format is alphanumeric, left-justified, and padded on the right with blanks.

List Library Member response

Expedite/CICS returns the standard Expedite/CICS response to the user program, using the EXPCRSP format. For information about the response COMMAREA format, see “Command processor responses” on page 63.

This value:	Indicates:
HI000	The command completed successfully; there is more data to retrieve. To retrieve the additional data, reissue the command using the same TSQ name. Expedite/CICS will use the information in Item 1 to retrieve the data and will append it to the item(s) already retrieved.
HI 675	The command completed successfully; there are no more library member items to retrieve.
HIxxx	The data sent to the command processor contained an error. For a list of error messages and recommended actions, see <i>Expedite/CICS Messages</i> .



NOTE:

1. Each time you issue the List Library Member command, you can retrieve only as many library member items as can be contained in your specified data transmission size.
2. Item 1 in the TSQ contains the next locator value or blanks. If subsequent invocations of the command are required to get more data, Expedite/CICS will use Item 1 of the queue to determine where to continue. Additional data retrieved will be appended to the same queue.

Library Member List Entry

The format of the Library Member List Entry is shown below; its length is 159 bytes. This entry format is received when the List Library Member command is used. Data is returned in the TSQ specified in the command. Each item in the TSQ contains one Library Member List entry.

Table 50. Library Member List entry

Column	Size	Name	Description
1	8	MLE-MEMNAME	Member name
9	20	MLE-CREATOR	User ID of the creator

Table 50. Library Member List entry

Column	Size	Name	Description
29	6	MLE-CREDATE	Date created
35	6	MLE-CRETIME	Time created
41	20	MLE-UPDATER	User ID of the last to update
61	6	MLE-UPDDATE	Date last updated
67	6	MLE-UPDTIME	Time last updated
73	8	MLE-MEMLNGTH	Member length
81	79	MLE-MEMDESC	Member description

MLE-MEMNAME

This field contains the name of the member. The format is alphanumeric, left-justified, and padded on the right with blanks.

MLE-CREATOR

This field contains the creator's user ID. The format is alphanumeric, left-justified, and padded on the right with blanks.

MLE-CREDATE

This field contains the date, YYMMDD, the library member was defined. The system defaults to your local time zone.

MLE-CRETIME

This field contains the time, HHMMSS, the library member was defined. The system defaults to your local time zone.

MLE-UPDATER

This field contains the user ID of the last user to update this member.

MLE-UPDDATE

This field contains the date, YYMMDD, the library member was last updated. The system defaults to your local time zone.

MLE-UPDTIME

This field contains the time, HHMMSS, the library member was last updated. The system defaults to your local time zone.

MLE-MEMLNGTH

This field contains the length of the member in bytes.

MLE-MEMDESC

This field contains the description associated with this member.

List Verify command

Following the List Define command, use the List Verify command to:

- Verify the Information Exchange addresses on a distribution list are valid and authorized to send and receive messages to and from your account/user ID.
- Obtain information about distribution lists.

The List Verify command does not produce an immediate response, but a response from Information Exchange Account/Userid, *SYSTEM* *LSTRSP*, will be placed in your mailbox with a user class of **LIST** or **LISTNAME**, depending on the value in the **LVF-TYPECMND** field.

The copybook for this command is EXPLSTV.

List Verify command COMMAREA format

To verify a distribution list, pass the following COMMAREA format and values to the command processor.

Table 51. List Verify command COMMAREA format

Column	Size	Name	Description	Value
1	1	LVF-PASS	Pass-through indicator	1
2	19	LVF-FILLER	Filler	
21	8	LVF-COMMAND	Command name	SDILSTV
29	8	LVF-ACCNTNO	User's account ID	Account ID
37	8	LVF-USERID	User's user ID	User ID
45	8	LVF-LSTNAME	Distribution list ID	List ID
53	1	LVF-TYPECMND	Type of SDILSTV command	L, D, C, A, R, S, or blank
54	1	LVF-MSGCHRG	Message charge validation level	blank



NOTE: The List Verify command is command-processor supported and can be issued from the Display Application. Because this was not true in earlier Expedite/CICS versions, provision has been made so this command can still be issued using the Passthrough option. Existing applications that use it this way are not affected.

Field descriptions are provided below.

LVF-PASS

This field indicates whether the command being submitted is defined to the command processor as a pass-through command or one supported by the command processor. For this command, the value must be 1.

LVF-FILLER

Leave this field blank. It is either not required by Expedite/CICS, or the value is supplied by Expedite/CICS and your application cannot override it.

LVF-COMMAND

This field contains command name SDILSTV, which identifies this as the List Verify command. The format is alphanumeric, left-justified, and padded on the right with blanks.

LVF-ACCTNO

This field contains your account ID. The format is alphanumeric, left-justified, and padded on the right with blanks.

LVF-USERID

This field contains your user ID. The format is alphanumeric, left-justified, and padded on the right with blanks.

LVF-LSTNAME

This field contains the name of the list you want to verify. The format is alphanumeric, left-justified, and padded on the right with blanks.

LVF-TYPECMND

The value in this field indicates how you want Information Exchange to verify the list named in the **LSTNAME** field. If you specify option **R**, **S**, or **B**, you will receive a system error for each user to whom you are not authorized to send or receive.

This code:	Indicates:
L	A list of users in a permanent list. A message is built with each 20 characters of message text containing a user identification in the same format as that used in the List Define command (alias type, table name, or Information Exchange address).
D	A list of a user's permanent list. A message is built with each 8 characters of message text containing a list name.
C	A list of users in an account or group list. A message is built with each 20 characters of message text containing a user ID in the same format as that used in the List Define command (alias type, table name, or Information Exchange address).
A	A list of account and group lists. A message is built with each 8 characters of message text containing a list name.
R	The list is to be verified for receiving messages from the user IDs in the list. The user IDs in the list must be valid in Information Exchange and must be authorized to send messages to your user ID.
S	The list is to be verified for sending messages to the user IDs in the list. The user IDs in the list must be valid in Information Exchange and must be authorized to receive messages from your user ID.
blank	Both receive and send verifications are to be done.

LVF-MSGCHRG

The value in this field indicates which level of message-charge validation is to be performed, if any, along with the basic user ID and communication authorization indicated by the **TYPECMND** field. For more information, see the Send Message command in the *Information Exchange Interface Programming Guide*.

The value, blank, indicates that the verification is to be done only on the basis of valid user ID and communications authority. Testing of valid message-charge classes will not be done. The Information Exchange charge values are listed below.

This code:	Indicates that charges are paid by:
1	The receiver.
3	The receiver, if agreed to by the receiver, otherwise, the library owner pays.
5	The sender if agreed to by the library owner, otherwise, the receiver pays.
6	The sender.

The send verification checks that your user ID is authorized to send the other users on the list a message with the corresponding **MSGCHRG** value. The receive verification checks that each of the other users is authorized to send a message to your user ID, with the corresponding **MSGCHRG** value.

List Verify response

Expedite/CICS returns the standard Expedite/CICS response to the user program, using the EXPCRSP format. For information about the response COMMAREA format, see “Command processor responses” on page 63.

This value:	Indicates:
HI000	The command was processed successfully. A list verify request is processed asynchronously.
HIxxx	The data sent to the command processor contained an error. For a list of error messages and recommended actions, see <i>Expedite/CICS Messages</i> .



NOTE: Information Exchange error messages associated with this command are placed in the user’s mailbox from *SYSTEM* *ERRMSG*

Load Test Messages pass-through command

Information Exchange maintains a small group of test messages you can use to test your system, a list of which is provided in the Information Exchange Interface Programming Guide. Use the Load Test Messages command to move the messages into an Information Exchange mailbox and receive them with the Receive Message command. The Load Test Messages command is not directly supported by the Expedite/CICS command processor and is sent to Information Exchange using pass-through.

Load Test Messages command COMMAREA format

To load the appropriate test messages, pass the following COMMAREA format and values to the command processor.

Table 52. Load Test Messages command COMMAREA format

Column	Size	Name	Description	Value
1	1	PS-PASS	Pass-through indicator	1
2	8	PS-FNAM	File containing the remainder of the command	TSQ name
10	2	PS-FTYP	File type	TS
12	1	PS-DTYPE	Data type	blank
13	8	PS-PAD2	Filler	blank
21	8	PS-COMMAND	Command name	SDILTST
29	8	PS-ACCNTNO	Account name	Account name
37	8	PS-USERID	User ID	User ID name
45	8	PS-SESSKEY	Session access key	blank



NOTE: The command processor does not provide default values for pass-through commands. You must blank out or type values into all fields. You must also place the rest of the command in the TSQ name field.

Use the Receive Message command to receive the messages normally. Specify *SYSTEM* *TSTMSG* as the sender's Account/Userid.

Load Test Messages command temporary storage queue format

Use the format below to store the remainder of the Load Test Messages command in the TSQ specified in the PS-FNAM field in the COMMAREA.

Table 53. Load Test Messages command temporary storage queue format

Column	Size	Name	Description
1	3	LOMSGNO	Low message number

Table 53. Load Test Messages command temporary storage queue format

Column	Size	Name	Description
4	3	HIMSGNO	High message number
7	1	EXPAND	Expansion indicator

The test messages you can request include the following:

Test message:	Will test:
0	Numerics 0-9
1	Uppercase alphabet characters
2	Lowercase alphabet characters
3	Numerics 0 - 9 and uppercase and lowercase alphabet characters.
4	Special characters.
5	All 256 EBCDIC characters in ascending sequence.

The descriptions of the fields you place in the TSQ are provided below.

LOMSGNO

This field contains the number of the first of a series of test messages you are requesting. If **LOMSGNO** is the same as **HIMSGNO**, only one message will be sent. This is a required field. The format is numeric, right-justified, and padded on the left with zeros.

HIMSGNO

This field contains the number of the last of a series of test messages you are requesting. **HIMSGNO** must be greater than or equal to **LOMSGNO**. If **HIMSGNO** is the same as **LOMSGNO**, only one message is sent. This is a required field. The format is numeric, rightjustified, and padded on the left with zeros.

EXPAND

This field contains a command expansion-level indicator which must be **1**. Invalid values default to blank.

Message Inquiry pass-through command

Use the Message Inquiry command to request a report from Information Exchange that includes the following information:

- Amount of user messages available, measured according to the Data transmission size set in the System Options panel.
- Age of the oldest message sent to you by another user.
- Amount of Information Exchange system messages available.
- Age of the oldest Information Exchange message.
- Total message data available, measured according to the data transmission size specified on the System Options panel.
- Maximum storage needed to store the largest message or message group, measured according to the Data transmission size specified in the System Options panel. The Message Inquiry command is not directly supported by the Expedite/CICS command processor and is sent to Information Exchange using pass-through.

The copybook for this command is EXPINQM.

Message Inquiry command COMMAREA format

To issue a Message Inquiry command, pass the following COMMAREA format and values to the command processor.

Table 54. Message Inquiry command COMMAREA format

Column	Size	Name	Description	Value
1	1	PS-PASS	Pass-through indicator	1
2	8	PS-FNAM	File containing the remainder of the command	TSQ name
10	2	PS-FTYP	File type	TS
12	1	PS-DTYPE	Data type	blank
13	8	PS-PAD2	Filler	blank
21	8	PS-COMMAND	Command name	SDIINQM
29	8	PS-ACCNTNO	Account name	Account name
37	8	PS-USERID	User ID	User ID name
45	8	PS-SESSKEY	Session access key	blank



NOTE: The command processor does not provide default values for pass-through commands. You must blank out or type values into all fields.

Message Inquiry command temporary storage queue format

Use the format below to store the remainder of the Message Inquiry command in the TSQ specified in the **PS-FNAM** field in the COMMAREA.

Table 55. Message Inquiry command format

Column	Size	Name	Description
1	8	INQMTRID	The value in the Inquiry response command name field is placed in the first 8 characters of the Message Inquiry response. Format: alphanumeric, left-justified, padded on the right with blanks
9	1	EXPAND	The Expansion indicator field specifies a command expansion-level indicator which must be 1. Invalid values default to blank.

The descriptions of the fields you place in the temporary storage queue are:

INQMTRID

The value of this field is placed in the first 8 characters of the Message Inquiry response. The format is alphanumeric, left-justified, and padded on the right with blanks.

EXPAND

This field contains a command expansion-level indicator which must be 1. Invalid values default to blank.

Message Inquiry response

Expedite/CICS returns the following information in response to the Message Inquiry command: The response length is 93 bytes. This layout will be returned in RSPQOUT; for more information, see “COMMAREA format for pass-through” on page 64.

Table 56. Message Inquiry command response

Column	Size	Name	Description
1	8	COMMAND	Command name
9	8	ACCNTNO	Account ID
17	8	USERID	User ID
25	8	SESSKEY	Session access key
33	6	INQDATE	Date of inquiry
39	6	INQTIME	Time of inquiry
45	6	DATAMSGS	Data messages available
51	12	DATAAGE	Age of oldest data message

Table 56. Message Inquiry command response

Column	Size	Name	Description
63	6	SERVMSG	System messages available
69	12	SERVAGE	Age of oldest system message
81	6	TOTLDATA	Total amount of message data available.
87	6	MAXSIZ	Size of largest message or group
		EXPAND	Expansion indicator

The descriptions of the fields returned to you in the response are:

COMMAND

This field contains the value from the INQMTRID field of the Message Inquiry command that invoked this response. The format is alphanumeric, left-justified, and padded on the right with blanks.

ACCNTNO

This field contains an account ID and is used with the **USERID** field to identify a user. The format is alphanumeric, left-justified, and padded on the right with blanks.

USERID

This field contains a user ID and is used with the **ACCNTNO** field to identify a user. The format is alphanumeric, left-justified, and padded on the right with blanks.

SESSKEY

This field contains the value sent to your system in the Session Start response. The format is alphanumeric, left-justified, and padded on the right with blanks.

INQDATE

This field contains the date the inquiry was processed. The format is numeric (YYMMDD) and right-justified.

INQTIME

This field contains the time the inquiry was processed. The format is numeric (HHMMSS) and right-justified.

DATAMSGS

This field contains the amount of user message data available, measured in terms of the data unit size specified in the **MAXMSGSZ** field of the Session Start command. The format is numeric, right-justified, and padded on the left with zeros.

DATAAGE

This field contains the age of the oldest data message available. The format is numeric (YYMMDDHHMMS S—local) and right-justified.

SERVMSG

This field contains the amount of Information Exchange message data available.

SERVAGE

This field contains the age of the oldest Information Exchange message available. The format is numeric (YYMMDDHHMMSS).

TOTLDATA

This field contains a value that indicates the total amount of message data available, measured in terms of the data unit size specified in the **MAXMSGSZ** field of the Session Start command. The format is numeric, right-justified, and padded on the left with zeros.

MAXSIZ

This field contains the amount of storage required to store the largest single message or message group available. The format is numeric, right-justified, and padded on the left with zeros.

EXPAND

This field contains the value from the EXPAND field of your Message Inquiry command.

Message Queue Query command

You can use this command to obtain a list of the items in your Information Exchange mailbox. The information will be returned in the temporary storage queue (TSQ) specified in the **MQQTSQUEUE** field. Each item will have a format as shown in “Message Queue Entry” on page 226.

The copybook for this command is EXPQUMS.

Table 57. Message Queue Query command

Column	Size	Name	Description	Value
1	1	MQQ-PASS	Pass-through indicator	Zero
1	8	MQQ-TSQUEUE	TSQ name	Queue name
10	11	MQQ-FILLER	Filler	
21	8	MQQ-COMMAND	Command	SDIQUMS
29	8	MQQ-ACCNTNO	User’s Account ID	Account ID
37	8	MQQ-USERID	User’s User ID	User ID
45	1	MQQ-TYPRSPN	Response type requested	1, 2, 3, or 4
46	1	MQQ-EXPAND	Expansion indicator	1 or 2

MQQ-PASS

This field indicates whether the command being submitted is defined to the command processor as a pass-through command or one supported by the command processor. For this command, the value must be zero.

MQQ-TSQNAME

This field identifies the TSQ file name that will contain the data upon successful completion of the command. The data format of each item in the TSQ will be as shown in “Message Queue Entry” on page 226. Data starts in item 2 of TSQ.

MQQ-FILLER

Leave this field blank. Either it is not required by Expedite/CICS, or the value is supplied by Expedite/CICS and your application cannot override it.

MQQ-COMMAND

This field contains a command name of SDIQUMS, which identifies this as the Message Queue Query command. The format is alphanumeric, left justified, and padded on the right with blanks.

MQQ-ACCNTNO

This field contains your account ID. The format is alphanumeric, left-justified, and padded on the right with blanks.

MQQ-USERID

This field contains your user ID. The format is alphanumeric, left-justified, and padded on the right with blanks.

MQQ-TYPRSPN

This field contains a value that determines the type of response Information Exchange generates.

This value:	Indicates:
1	Only the Information Exchange header data is shown in the response. Messages in the process of being received are not returned.
2	The Information Exchange header data plus the CDH data for those message groups with common data headers are shown in the response. Messages in the process of being received are not returned.
3	Only the Information Exchange header data is shown in the response. Messages in the process of being received are returned.
4	The Information Exchange header data plus the CDH data for those message groups with common data headers are shown in the response. Messages in the process of being received are returned.

MQQ-EXPAND

This field contains a command expansion-level indicator. It must contain either the value 1 or 2. An expansion level of 1 does not return a receive indicator in the message queue entry. An expansion level of 2 returns a receive indicator in the message queue entry.

Message Queue Query response

Expedite/CICS returns the standard Expedite/CICS response to the user program, using the EXPCRSP format. For information about the response COMMAREA format, see “Command processor responses” on page 63.

This value:	Indicates:
HI000	The command completed successfully. There is more data to retrieve. To retrieve the additional data, reissue the command using the same TSQ name. Expedite/CICS will use the information in Item 1 to retrieve the data and will append it to the item(s) already retrieved.
HI675	The command completed successfully. There is more data to retrieve. To retrieve the additional data, reissue the command using the same TSQ name. Expedite/CICS will use the information in Item 1 to retrieve the data and will append it to the item(s) already retrieved.
HIxxx	The data sent to the command processor contained an error. For a list of error messages and recommended actions, see Expedite/CICS Messages.

**NOTE:**

1. Each time you issue the Message Queue Query command, you can retrieve only as many message queue query items as can be contained in your specified data transmission size.
2. Item 1 in the TSQ contains the next locator value or blanks. If subsequent invocations of the command are required to get more data, Expedite/CICS will use Item 1 of the queue to determine where to continue. Additional data retrieved will be appended to the same queue.

Message Queue Entry

Expansion-level 1

This is the format of a single message queue entry; its length is 96 bytes plus 416 bytes for the CDH. The CDH is only present if you used a value of 2 in the MQQ-TYPRSPN field of the Message Queue Query command. This is the layout of each item in the TSQ specified in the MQQ-TSQUEUE field. Table 58. Message Queue Query entry (expansion-level 1)

Table 58. Message Queue Query entry(expansion-level 1)

Column	Size	Name	Description
1	20	MQE-MSGID	Message ID string
21	20	MQE-MSGSNDR	Message sender
41	8	MQE-MSGNAME	Message name
49	5	MQE-MSGSEQ	Message input sequence
54	1	MQE-MSGNCLAS	Message network class
55	8	MQE-MSGUCLS	User message class
63	8	MQE-SYSTYPE	Sender's system type
71	4	MQE-SYSLEVEL	Sender's system level
75	10	MQE-MSGTXTSZ	Size of message group text
85	6	MQE-MSGDATE	Date message available
91	6	MQE-MSGTIME	Time message available
97	n	MQE-CDH	Common data header (CDH) data

Expansion-level 2

This is the format of a single message queue entry; its length is 97 bytes plus 416 bytes for the CDH. The CDH is only present if you used a value of 2 or 4 in the MQQ-TYPRSPN field of the Message Queue Query command. This is the layout of each item in the TSQ specified in the MQQ-TSQQUEUE field.

Table 59. Message Queue Entry (expansion-level 2)

Column	Size	Name	Description
1	20	MQE-MSGID	Message ID string
21	20	MQE-MSGSNDR	Message sender
41	8	MQE-MSGNAME	Message name
49	5	MQE-MSGSEQ	Message input sequence
54	1	MQE-MSGNCLAS	Message network class
55	8	MQE-MSGUCLS	User message class
63	8	MQE-SYSTYPE	Sender's system type
71	4	MQE-SYSLEVEL	Sender's system level
75	10	MQE-MSGTXTSZ	Size of message group text
85	6	MQE-MSGDATE	Date message available
91	6	MQE-MSGTIME	Time message available
97	1	MQE-RCVSTAT	Receive indicator
98	n	MQE-CDH	Common data header (CDH) data

MQE-MSGID

This field contains the message identifier that Information Exchange assigns. It is the hexadecimal representation of the message delivery class and a unique identifier. This value can be used in the RM-MSGKEY field to selectively receive a single item of mail from your mailbox.

MQE-MSGSNDR

This field contains the sender's identification. If the sender is on a different system, the first four characters are the alias type and system identification; if the sender is on the same system you are on, the first four characters are blank. This is followed by the Account/Userid of the message sender.

MQE-MSGNAME

This field contains the message name the message sender assigns. The format is alphanumeric, left-justified, and padded on the right with blanks.

MQE-MSGSEQ

This field contains the message input sequence the message sender assigns. The format is alpha-numeric, left-justified, and padded on the right with blanks.

MQE-MSGNCLAS

This field contains the message network class that the message sender and your trading partner list assigns.

This code:	Indicates:
blank	Normal message with no CDH available.
T	Test mode message with no CDH available.
S	Normal message with CDH available.
R	Test mode message with CDH available.



NOTE: If this field contains **R** or **S** and **TYPRSPN** of the Message Queue Query command contains a 2, the CDH for this message group immediately follows **MSGTIME** below; otherwise, the system does not return **CDH** data.

MQE-MSGUCLS

This field contains the user message class the message sender assigns.

MQE-SYSTYPE

This field contains the message sender's system type, as it is set in the Session Start command.

MQE-SYSLEVEL

This field contains the message sender's system level, as it is set in the Session Start command.

MQE-MSGTXTSZ

This field contains the total text size, exclusive of any Information Exchange headers or common data headers. The format is numeric.

MQE-MSGDATE

This field contains the date the message is available for receipt in your local time zone, as set in your Session Start command. The format is YYMMDD.

MQE-MSGTIME

This field contains the time the message is available for receipt in your local time zone, as set in your Session Start command. The format is HHMMSS.

MQE-RCVSTAT (expansion-level 2 only)

This field contains the receive indicator.

This code:	Indicates:
Y	The message is in the process of being received.
N	The message was marked for force selective receive criteria.
blank	The message is not in the process of being received nor was it marked for force selective criteria.

MQE-CDH

If TYPRSPN of the Message Queue Query command contains 2 or 4, and MSGNCLAS contains R or S, the CDH follows. Expedite/CICS will reformat this field to match the format shown in Table 26 on page 132.

Probe command

This command enables users to predetermine the validity of Information Exchange addresses to which they want to send messages, and the message payment levels associated with those Information Exchange addresses. It is recommended this command be used when destinations have not been previously validated. The command processor automatically issues this command if the value in the Send File command **SF-CVIFY** is **Y**; it sets the value in **MSGCHRG** to **3**.

The copybook for this command is EXPPROB.

Probe command COMMAREA format

To issue a Probe command, pass the following COMMAREA format and values to the command processor.

Table 60. Probe Command COMMAREA format

Column	Size	Name	Description	Value
1	1	PC-CMDPASS	Pass-through indicator	Zero
2	8	PC-CMDNM	File name	blank
10	2	PC-CMDFTYPE	File type	blank
12	1	PC-CMDDTYPE	Data type	blank
13	8	PC-CMDPAD2	Filler	blank
21	8	PC-COMMAND	Command name	SDIPROB
29	8	PC-ACCNTNO	User's account	Account name
37	8	PC-USERID	User ID	User name
45	8	PC-SESSKEY	Session access key	blank
53	1	PC-EXPAND	Expansion indicator	blank
54	8	PC-RETRSPC	Response command name	Response command
62	1	PC-CMDMODE	Synchronous or asynchronous response	A, R, C, or L
63	1	PC-MSGCHRG	Message service charges	1 to 6
64	1	PC-DESTATYPE	Alias type	G, O, or P
65	3	PC-DESTITBLID	Alias table ID	Alias table ID for PCDESTACCT and PCDESTUSER
68	8	PC-DESTACCT	Destination account	Destination account
76	8	PC-DESTUSER	Destination user	Destination user ID

This value:	Means:
>blank<	Expedite/CICS supplies the field value. You can use the default value in your application, or your application can override it.
blank	The field is either not required, or the value is supplied by Expedite/CICS and your application cannot override it.

The descriptions of the fields you place in the COMMAREA are:

PC-CMDPASS

This field indicates whether the command being submitted is defined to the command processor as a pass-through command or one supported by the command processor. For the Probe command, the value must be zero.

PC-CMDNM

Leave this field blank. Either it is not required by Expedite/CICS, or the value is supplied by Expedite/CICS and your application cannot override it.

PC-CMDFTYPE

Leave this field blank. Either it is not required by Expedite/CICS, or the value is supplied by Expedite/CICS and your application cannot override it.

PC-CMDDTYPE

Leave this field blank. Either it is not required by Expedite/CICS, or the value is supplied by Expedite/CICS and your application cannot override it.

PC-CMDPAD2

This field contains blanks.

PC-COMMAND

This field must contain SDIPROB, which identifies this as the Probe command. The format is alphanumeric, left-justified, and padded on the right with blanks.

PC-ACCNTNO

This field, along with the PC-USERID field, serves to identify the user. The format is alphanumeric, left-justified, and padded on the right with blanks.

PC-USERID

This field, along with the PC-ACCNTNO field, serves to identify the user. The format is alpha-numeric, left-justified, and padded on the right with blanks.

PC-SESSKEY

Leave this field blank. Expedite/CICS supplies the value for it and your application cannot override it.

PC-EXPAND

This field is not required by Expedite/CICS and must be left blank.

PC-RETRSPC

The value from this field is placed in the first 8 characters of the Probe response returned to your user ID. The format is alphanumeric, left-justified, and padded on the right with blanks.

PC-CMDMODE

This field indicates if a synchronous response is to be returned to this command. The valid values for this field are:

Value: Definition:

- A** Asynchronous: indicates the command is to be asynchronous; the response will be placed in your Information Exchange mailbox..
- R** R Response: indicates the command is to be synchronous and give an immediate response. If the RESPCODE field of the response is 4, a deferred probe response will not be placed in your mailbox at a later date.
- C** Complete: indicates the command is to be synchronous and give an immediate response. If the RESPCODE field of the response is 4, a deferred probe response will be placed in your mailbox at a later date.
- L** List: indicates the command is issued against a distribution list instead of against a user. PC-DESTACCT contains the list name.

If this field contains any other value, C is assumed and the command is processed accordingly with no error message being generated.

PC-MSGCHRG

Place the same value here that is in the MSGCHRG field of a send message command to validate the charge scheme. If other than the numeric characters 1 to 6 are coded, the value 3 will be assumed and the command will be processed accordingly with no error message being generated.

PC-DESTATYPE

This field contains one of the following codes that indicate whether this is a true Information Exchange address or an alias ID entry.

- | This code: | Indicates: |
|-------------------|---|
| G | An alias-table reference to a global table. |
| O | An organization (account) alias table. |
| P | A private table. |

PC-DETTBLID

This field names the alias table to be used to search for the account name and user ID if PCDESTATYPE is G, O, or P.

PC-DESTACCT

This field specifies the Information Exchange alias name or account name of the desired destination.

PC-DESTUSER

This field specifies the Information Exchange alias ID or user ID of the desired destination.

Asynchronous Probe response

Information Exchange produces the following information in response to the Probe command if an asynchronous response was requested. This is determined by the value in the PCCMDMODE. It is placed in your Information Exchange mailbox as a single Information Exchange message from *SYSTEM* *PRBRSP*, with user class #SPROBE.

Table 61. Asynchronous Probe response

Column	Size	Name	Description
1	20	DESTID	Destination ID
21	1	RESPCODE	Indicates validity of destination

The descriptions of the fields returned to you in the response are:

DESTID

This field is the destination you sent on the Probe command.

RESPCODE

This indicates the type of response, as follows:

This code:	Indicates:
1	Messages may be sent to the indicated destination. If the probe is directed to a distribution list, the response indicates that the list exists, but does not imply the ability to send to any particular user in the list. Use the List Verify command to determine which users in a list are valid, and which are invalid
2	The destination is invalid. If the probe is directed to a list, this response indicates that the list does not exist.
3	Although the destination is valid, the trading partner's list prevents you from sending to it
4	Information Exchange is unable to send an immediate indication of the validity of the destination. If C was specified in the Probe command PC-CMDMODE field, the system will place a deferred probe response in your mailbox. All probes to intersystem destinations will return this code

Synchronous Probe response

If a synchronous response was requested to the Probe command, the Expedite/CICS command processor returns the following response as an overlay of the EXPCRSP COMMAREA. The response length is 56 bytes. For more information, see “COMMAREA format for response HI000 or HI001” on page 64.

Table 62. Synchronous Probe response

Column	Size	Name	Description
1	5	MSGNUM	HI001 or HIxxx
6	2	MSG SVC	Severity code
8	8	COMMAND	Response command
9	8	ACCNTNO	Account
17	8	USERID	User ID
25	8	SESSKEY	Session access key
33	1	EXPAND	Expansion indicator
34	2	ERRCODE	Error code
36	20	DESTID	Destination ID
56	1	RESPCODE	Indicates validity of destination

The descriptions of the fields returned to you in the response are:

MSGNUM

This field contains a message number that indicates the success of the Synchronous Probe command.

This value:

Indicates:

HI001

Indicates the Synchronous Probe command completed successfully or returned an SDIERR response beginning in column eight (refer to the SDIERR copybook for the command overlay)

HIxxx

The data sent in the Synchronous Probe command contained an error.

MSG SVC

This field contains a code that indicates the severity of the message returned in the MSGNUM field.

COMMAND

The command name contains the value from PC-RETRSPC of the SDIPROB command.

ACCNTNO

This field is used with the USERID field to identify the user. The format is alphanumeric, left-justified, and padded on the right with blanks.

USERID

Probe command

This field is used with the ACCNTNO field to identify the user. The format is alphanumeric, left-justified, and padded on the right with blanks.

SESSKEY

This field contains the value sent to your system in the Session Start response. The format is alphanumeric, left-justified, and padded on the right with blanks.

EXPAND

This field contains the command expansion-level indicator set on the SDIPROB command.

ERRCODE

This field specifies error code values.

This value:	Indicates:
00	There was no error processing the command.
04	There was a recoverable error.
08	There was a non-recoverable error.



NOTE: If the value is 08, issue a Receive Message command to retrieve the associated error messages.

DESTID

This field is the destination as sent on the Probe command.

RESPCODE

This indicates the type of response, as follows:

This code:	Indicates:
1	Messages may be sent to the indicated destination. If the probe is directed to a distribution list, the response indicates that the list exists, but does not imply the ability to send to any particular user in the list. Use the List Verify command to determine which users in a list are valid, and which are invalid.
2	The destination is invalid. If the probe is directed to a list, this response indicates that the list does not exist.
3	Although the destination is valid, the trading partner's list prevents you from sending to it.
4	Information Exchange is unable to send an immediate indication of the validity of the destination. If C was specified in the Probe command PCCMDMODE field, the system will place a deferred probe response in your mailbox. All probes to intersystem destinations will return this code.

Purge Message command

You can use this command to delete messages from your Information Exchange mailbox without receiving them. To use this command, the **Use purge message command** flag in your Information Exchange profile must be set to **Y**.

The copybook for this command is EXPPRGM.

Table 63. Purge Message command

Column	Size	Name	Description	Value
1	1	PRG-PASS	Pass-through indicator	Zero
2	19	PRG-FILLER	Filler	
21	8	PRG-COMMAND	Command	SDIPRGM
29	8	PRG-ACCNT	Account ID	Account ID
37	8	PRG-USERID	User ID	User ID
45	20	PRG-MSGKEY	Message key to delete	20-character message ID

PRG-PASS

This field indicates whether the command being submitted is defined to the command processor as a pass-through command or one supported by the command processor. For this command, the value must be zero.

PRG-FILLER

Leave this field blank. Either it is not required by Expedite/CICS, or the value is supplied by Expedite/CICS and your application cannot override it.

PRG-COMMAND

This field contains a command name of SDIPRGM, which identifies this as the Purge Message command. The format is alphanumeric, left-justified, and padded on the right with blanks.

PRG-ACCOUNT

This field contains your account ID. The format is alphanumeric, left-justified, and padded on the right with blanks.

PRG-USERID

This field contains your user ID. The format is alphanumeric, left-justified, and padded on the right with blanks.

PRG-MSGKEY

This field contains the 20-character message identifier that is returned in a previously processed Message Queue Query response. The value in the PRG-MSGKEY field identifies the message that is to be purged from your Information Exchange mailbox.

Purge Message response

Expedite/CICS returns the standard Expedite/CICS response to the user program, using the EXPCRSP format. For information about the response COMMAREA format, see “Command processor responses” on page 63.

This value:	Indicates:
HI370	The command completed successfully. The message was purged from your Information Exchange mailbox.
HI371	The purge message command that was sent in to Information Exchange was too short to contain all the required fields.
HI372	You attempted to purge a message from your Information Exchange mailbox that no longer exists. It may have already been received or purged.
HI373	You attempted to purge a message from your Information Exchange mailbox that is currently being received.
HI374	You attempted to purge a message from your Information Exchange mailbox, but your Information Exchange user profile indicates that you are not authorized to use the purge message command.
HIxxx	The data sent to the command processor contained an error. For a list of error messages and recommended actions, see <i>Expedite/CICS Messages</i> .

Receive Message command

Use the Receive Message command to receive mailbox responses and mailbox messages and files from Information Exchange. You can use the Receive Message command to issue either a single or a continuous receive.

The copybook for this command is EXPRCVM.

Receive Message command COMMAREA format

To issue a Receive Message command, pass the following COMMAREA format and values to the command processor.

Table 64. Receive Message command COMMAREA format

Column	Size	Name	Explanation	Value
1	8	COMMAND	Command name	
9	8	ACCNTNO	Account	
1	1	RM-PASS	Pass-through indicator	Zero or 4
2	8	RM-FNM	Receive data file name	File name or program name
10	2	RM-FTYPE	Receive data file type	TS, TD, VS, or PG
12	1	RM-DTYPE	Data type	E, A, B, or O
13	1	RM-DISP	File disposition	N or H
14	1	RM-CNTL	Retain control headers	Y, N, E, or F.
15	1	RM-WRAP	Record handling	W, S, or V
16	5	RM-LENG	Maximum record length	00000 - 28000
21	8	RM-COMMAND	Command name	SDIRCVM
29	8	RM-ACCNTNO	User's account ID	Account name
37	8	RM-USERID	User's ID	User ID name
45	8	RM-SESSKEY	Session access key	blank
53	8	RM-REFNAME	Reference name	blank
61	8	RM-DESTACCT	Source account	Source account
69	8	RM-DESTUID	Source user ID	Source user ID
77	1	RM-DESTTYPE	Source type	Blank, D, L, or A
78	8	RM-MSGUCLS	Message class	User message classification
86	8	RM-QMSGTRID	Queued message name	blank
94	8	RM-IMSGTRID	Immediate message name	blank

Table 64. Receive Message command COMMAREA format

Column	Size	Name	Explanation	Value
102	8	RM-SMSGTRID	System message name	blank
110	1	RM-TYPECMND	Type of receive	blank, C, or E
111	5	RM-MAXMSGNO	Maximum number of messages	Maximum number of messages
116	8	RM-EXTRTN	Reserved	blank
124	1	RM-EXPAND	Expansion indicator	blank
125	1	RM-DTBLTYP	Alias table type	blank
126	3	RM-DTBLID	Alias table ID	blank
129	8	RM-ARCFID	Archive reference ID	Archive reference ID
137	20	RM-MSGKEY	Message group key	Message group key
 NOTE: You may use the fields above this note for pass-through values of zero or 4. The fields below this note may be used only when the pass-through value is 4.				
157	1	RM-RTYPE	Type of receive command	Y, N, blank
158	8	RM-EXCEPTS	Exception condition	Program name
166	4	RM-CALLID	Reserved for future use	blank
170	81	RM-FILLER	Reserved for future use	blank

This value:
Means:
>blank<

Expedite/CICS supplies the field values. You can use the default value in your application, or your application can override it.

blank

The field is either not required by Expedite/CICS, or the value is supplied by Expedite/CICS and your application cannot override it.

The descriptions of the fields you place in the COMMAREA are:

RM-PASS

This field indicates whether the command is defined to the command processor as a passthrough command or one supported by the command processor. For the Receive Message command, the value must be zero or 4. If you want to use column 157 or higher, the value must be 4.

RM-FNM

 This field specifies the name of the file where data is to be placed when received or the name of a receive program to be invoked when data is received. Define your destination file as variable and capable of holding the largest possible record size that will be received, which is either the data transmission size minus 125 bytes for the Information Exchange Receive Message header, or the size specified in the **RM-LENG** field.

RM-FTYPE

This field further identifies the file in which the data is placed or the receive program to be invoked when data is received:

This value: Means:

TS	Temporary storage (CICS limits you to receiving 32,767 records)
TD	Transient data
VS	VSAM ESDS
PG	Program name

RM-DTYPE

This field identifies the optional processing to be performed against the data received.

This value: Means:

E	EDI
A	CRLF
B	LL
O	Other

The command processor uses this indicator to process data being received. Data types X (X12), U (UCS), and T (EDIFACT or UN/TDI) used in previous releases are still valid but the recommended value for all EDI formatted data is E. See “Processing received data” on page 101 for more information.

RM-DISP

This field tells Expedite/CICS where to place the incoming data:

This value: Means:

N	Normal: indicates the user-specified destination.
H	Held: indicates status HELD; when ready, you must release or purge it using the display application.

RM-CNTL

Type a one-letter code that indicates how Expedite/CICS should handle the message header that identifies the source of the data. When you receive data with a File type of LL, CRLF, or OTHER, you can specify whether or not the Information Exchange long-format message headers are to be passed to the specified destination data set or user receive program. If the headers are passed to the receive destination, the first Information Exchange long format header for each mail item is written at the beginning of the data and the last Information Exchange ENDDATA header for each mail item is written when the receive has ended.

Information Exchange uses the common data header (CDH) to provide additional message descriptions; for example, the record length as it was stored on the sender's system, whether data is in binary format, or if a record delimiter is present.

This code: Tells Expedite/CICS to:

- Y** Pass the Information Exchange long-format message headers for each message or file to the file management destination.
- N** Discard any long-format message header; do not pass to the file management destination.
- E** Use the Information Exchange CDH information to determine how to process and write the data to the file management destination. Discard the headers.

If you receive data with option E, which does not contain the Information Exchange CDH, Expedite/CICS discards the header and processes the data as if the Retain header data field value is N
- F** Use the Information Exchange CDH information to determine how to process and write the data to the file management destination. Pass headers to the file management destination.

If you receive data with option F, which does not contain the Information Exchange CDH, Expedite/CICS passes headers to the file management destination and processes the data as if the Retain header data field value is Y

RM-WRAP

Type a one-letter code that indicates how records are to be stored.

This code: Tells Expedite/CICS to:

- S** Split each data record into multiple records if it exceeds the maximum record length. Pad any records less than the maximum record length up to the maximum record length with blanks. If S is used when receiving EDI data with File type value E, the data is first processed as detailed below, before being split further according to the maximum record length. If the maximum record length is zero, the data is processed exactly as described below.
 - For EDIFACT and UN/TDI, the data is written into 80-byte records.
 - For X12 and UCS, the data is written split by EDI segment.

If using this code and the maximum record length is greater than zero, results are unpredictable.
- W** Write the data to the destination divided into continuous records of size specified in the **Max record length** field. Pad the last record with blanks up to the maximum record length.

This code: Tells Expedite/CICS to:

- V** Format the data according to the **File type** field. Each record is stored individually with no padding. The maximum record length is ignored. For example, when processing LL data, write the data out based on the length of each record identified in the 2-byte logical-length characters at the beginning of each record. If the value in the File type field is O, the data is stored as it arrives from Information Exchange; thus, record size will be the Information Exchange segment size minus the Information Exchange headers.

RM-LENG

Specify the longest record you want to store. Expedite/CICS uses this field and the Handle records as field to determine how to pass the incoming file or message to the specified file management destination. The value in this field is numeric and is limited to 28000 bytes. If you specify a record length:

- Larger than the destination CICS storage can accept, Expedite/CICS truncates the data.
- Smaller than the CICS destination storage size, there will be no problem writing the record, unless it is an extrapartition transient data queue that has been defined with a fixed record format in the destination control table (DCT).
- Of zero, Expedite/CICS writes the data based on the **File type**.

RM-COMMAND

This field must contain SDIRCVM, which identifies this as the Receive Messages command. The format is alphanumeric, left-justified, and padded on the right with blanks.

RM-ACCNTNO

This field is used with the **RM-USERID** field to identify the user. The format is alphanumeric, left-justified, and padded on the right with blanks.

RM-USERID

This field is used with the **RM-ACCNTNO** field to identify the user. The format is alphanumeric, left-justified, and padded on the right with blanks.

RM-SESSKEY

Leave this field blank. Either it is not required by Expedite/CICS, or the value is supplied by Expedite/CICS and your application cannot override it.

RM-REFNAME

Leave this field blank. Either it is not required by Expedite/CICS, or the value is supplied by Expedite/CICS and your application cannot override it.

RM-DESTACCT

This field contains either an account number of the source from which you wish to receive messages (if the **RM-DESTTYPE** field contains **D**) or the name of a list (if the **RM-DESTTYPE** field contains **L**). The format is alphanumeric, left-justified, and padded on the right with blanks.

RM-DESTUID

This field contains the source user ID if the **RM-DESTTYPE** field contains D. This field is ignored if **RM-DESTTYPE** contains L. The format is alphanumeric, left-justified, and padded on the right with blanks.

RM-DESTTYPE

This field contains one of the following values which indicates the type of source name in the **RM-DESTACCT** field. The format is alphanumeric, left-justified, and padded on the right with blanks.

This code: Indicates:

- blank** This Receive Message command is to send any messages queued to your user ID regardless of the originating user ID. Any value in **RMDESTACCT** or **RM-DESTUID** is ignored by Information Exchange
- D** The **RM-DESTACCT** and **RM-DESTUID** fields identify a single source user ID from which you wish to receive messages
- L** **RM-DESTACCT** is the name of a list of user IDs from which you wish to receive messages. In this case, the **RM-DESTUID** field is ignored.
- A** This Receive Message command is to send all archived messages that have been requeued to the user's normal-priority message queue. Values in **RM-DESTACCT** or **RM-DESTUID** are ignored by Information Exchange.

RM-MSGUCLS

This field enables users to limit the messages received to those with the user classification specified here. Information Exchange will send only those messages, or message groups, whose originators specified in the **MSGUCLS** field of their Send Messages commands the same value as specified here. A question mark (?) can be used as a wild card to substitute for any character or characters. For example, AB 1? would select all users whose user classification begins with AB 1; ?999 would select all those that end with 999. The format is alphanumeric, left-justified, and padded on the right with blanks.



NOTE: Whether a given message will be sent to your user ID depends on whether it meets all the conditions specified in the four fields (**RM-DESTACCT**, **RM-DESTUID**, **RM-DESTTYPE**, and **RM-MSGUCLS**).

RM-QMSGTRID

Leave this field blank. It is either not required by Expedite/CICS, or the value is supplied by Expedite/CICS and your application cannot override it.

RM-IMSGTRID

Leave this field blank. It is either not required by Expedite/CICS, or the value is supplied by Expedite/CICS and your application cannot override it.

RM-SMSGTRID

Leave this field blank. It is either not required by Expedite/CICS, or the value is supplied by Expedite/CICS and your application cannot override it.

RM-TYPECMND

Expedite/CICS uses one of the following values entered in this field to determine how to format the message or file that is being received. The values you can enter are:

This value: Indicates:

blank	Single Receive.
C	Continuous Receive.
E	End Continuous Receive.
G	Get only the first item in the mailbox.



NOTE: A stop request does not immediately halt receive activity. The stop command is sent to Information Exchange and, whenever Information Exchange completes the message group, it is actively transmitting, then Information Exchange stops the receive by sending an ENDDATA to Expedite/CICS. Depending on the size of the message being received at the time, it might take some time before the receive stops.

RM-MAXMSGNO

If **RM-TYPECMND** contains a blank or a **C**, this field contains the maximum number of message segments you are prepared to receive. If you do not want transmission to cease, specify 00000; otherwise, the ENDDATA message is sent following the number of message segments specified in this field. The format is numeric, right-justified, and padded on the left with zeros.

RM-EXTRTN

Leave this field blank. Either it is not required by Expedite/CICS, or the value is supplied by Expedite/CICS and your application cannot override it.

RM-EXPAND

Leave this field blank. Either it is not required by Expedite/CICS, or the value is supplied by Expedite/CICS and your application cannot override it.

RM-DTBLTYP

Leave this field blank. Either it is not required by Expedite/CICS, or the value is supplied by Expedite/CICS and your application cannot override it.

RM-DTBLID

Leave this field blank. It is either not required by Expedite/CICS, or the value is supplied by Expedite/CICS and your application cannot override it.

RM-ARCFID

This field indicates that all messages received by this Receive Message command are to be placed in the short-term archive. The value in this field is used to identify messages in the archive for retrieval using the Archive Retrieve command. This reference ID should be unique for each.

Receive Message command. If this field is left blank, and the user's Information Exchange profile indicates that archive is to be forced, the session access key is used as an archive reference.



NOTE: The combination of a relatively short archive retention period and a relatively long continuous-receive operation may cause the user to lose messages intended for archiving. If, for example, a user has defined the short-term archive retention period as three days and then issues a Continuous Receive Messages command (**C** in **RMTYPECMND**) that is left in effect for longer than three days, those messages received after the third day are stored in the archive, but are immediately eligible for purging.

RM-MSGKEY

For a normal receive, specify blanks or zeros in this field. To receive a specific message group, insert the message group key (obtained with a Message Queue Query command) in this field. The single message group is then sent to your system, then an ENDDATA. This operates as though G were specified in **RM-TYPECMND** regardless of the actual value.

RM-RTYPE

This field specifies if EDI, non-EDI, or all data is to be received; it is only used if the value in **RM-PASS** is **4**.

This code: Specifies that Information Exchange is to:

- Y** Send only EDI messages
- N** Send only non-EDI messages
- blank** Send all messages that match this receive request.

RM-EXCEPTS

This field should contain the name of the user completion notification exit program you want to get control if an exception error condition occurs during receive processing; it is only used if the value in **RM-PASS** is **4**. The program will receive a COMMAREA with a non-HI000. This program can then take whatever action is appropriate for the error. For more information about the COMMAREA format for receive exception notification, see Table 22 on page 124.

RM-CALLID

Reserved for future use; it will be used only if the value in **RM-PASS** is **4**.

RM-FILLER

Reserved for future use.

Receive Message response

Expedite/CICS returns the standard Expedite/CICS response to the user program, using the EXPCRSP format. For information about the response COMMAREA format, see "Command processor responses" on page 63.

This value: Indicates:

- blank** Single Receive.

This value: Indicates:

- HI000** The command completed successfully. Mail items matching the receive criteria will be received asynchronously and delivered to the destination specified in the Receive command.
- HI001** An error may have occurred, indicated by SDIERR. The Information Exchange response is placed in the RSPDATA data field of the response COMMAREA. Your application should inspect this Information Exchange response to determine what action, if any, should be taken. For more information, see “SDIERR messages” on page 66.
- HIxxx** The data sent to the command processor contained an error. For a list of error messages and recommended actions, see Expedite/CICS Messages.

Received Message header

When data is received from Information Exchange, it is preceded by a Received Message header. Your application usually does not need to be concerned with this because Expedite/CICS processes the header to determine where data is located. However, when you receive system messages from Information Exchange that are written to the response destination; for example, Information Exchange acknowledgments, Expedite/CICS writes them to the response destination with the Received Message header (long format) attached to the front of the system message text. To help you process these system messages, the layout of the header is detailed below.

Table 65. Purge Message command

Column	Size	Name	Description
1	8	COMMAND	Command name
9	8	ACCNTNO	Account ID
17	8	USERID	User ID
25	8	SESSKEY	Session access key
33	1	MSGTXTOV	continued message indicator
34	5	MSGTXTLN	Message grouping indicator
40	8	DESTACCT	Source account ID
48	8	DESTUID	Source user ID
56	1	DESTTYPE	Destination type
57	8	MSGNAME	Message or group name
65	5	MSGSEQN	Message sequence number
70	1	MSGNCLS	Network message classification
71	8	MSGUCLS	User message classification
79	1	MSGCLASS	Message delivery class
80	1	MSGRCPTS	Receipts requested indicator.
81	1	MSGCHRG	Message service charge indicator

Table 65. Purge Message command

Column	Size	Name	Description
82	6	MSGSEQO	Message sequence out number
88	8	SYSTYPE	Source system type
96	4	SYSLEVEL	Source system level
100	1	EXPAND	Expansion indicator
101	8	EXTRTN	Reserved
109	6	MSGDATE	Message date
115	6	MSGTIME	Message time
121	1	MSGTZONE	Time and date zone.
122	1	DTBLTYP	Alias table type for DESTACCT and DESTUID
123	3	DTBLID	Alias table ID for DESTACCT and DESTUID
126	var	MSGTEXT	User's message text.

COMMAND

This field contains the value from **QMSGTRID**, **IMSGTRID**, or **SMSGTRID** of the Receive Messages command. Which value Information Exchange uses depends on whether the message was sent from an Information Exchange user using express delivery, a queued delivery method, or from Information Exchange itself. The format is alphanumeric, left-justified, and padded on the right with blanks.

ACCNTNO

This field contains your account ID. The format is alphanumeric, left-justified, and padded on the right with blanks.

USERID

This field contains your user ID. The format is alphanumeric, left-justified, and padded on the right with blanks.

SESSKEY

This field contains the value Information Exchange sends to your system in **SESSKEY** of the Session Start response. The format is alphanumeric, left-justified, and padded on the right with blanks.

MSGTXTOV

This field contains a message overflow indicator.

This value: Indicates:

blank A single-segment message. This is the only segment of the current message; it uses the long-format header.

This value:	Indicates:
S	The first segment of a multiple-segment message; it uses the long-format header.
C	An intermediate segment of a multiple-segment message; it uses the short-format header.
E	The last segment of a multiple-segment message; it uses the short-format header.

MSGTXTLN

This field contains the length of **MSGTEXT** in this segment. The format is numeric, rightjustified, and padded on the left with zeros.

MSGGRPIN

This field contains a message-grouping indicator.

This value:	Indicates:
blank	A single message and not part of a group of messages.
S	The first message of a group, where all messages within the group are delivered as a package, with no intervening messages from any other source.
C	A continuation message within a group.

This value:**E****Indicates:**

An ENDDATA message with no text and a MSGTXTLN containing zeros. Information Exchange sends an ENDDATA message when any of the following is true:

- The maximum number of messages you are prepared to receive (indicated by MAXMSGNO of the Receive Messages command) has been sent.



NOTE: If there are messages meeting the specified selection criteria remaining in the mailbox after the completion of this receive command, the characters: MORE, left-justified and padded with blanks will be placed in MSGNAME (field 11 of the long format header). The following conditions must be true in order for the characters: MORE to be assigned:

- TYPECMND (of the receive messages command) is not C.
- MAXMSGNO (of the receive messages command) is not zeros or blank.
- EXPAND (of the receive messages command) is 4.
- MSGGRPIN (of the long format header) is E.
- All the selected messages you requested using a noncontinuous Receive command have been sent.
- You end a continuous-receive command.

DESTACCT

This field, in conjunction with **DESTUID**, identifies the message sender. If the value in this field is *SYSTEM*, the message was generated by Information Exchange. The format is alphanumeric, left-justified, and padded on the right with blanks.

DESTUID

This field, in conjunction with **DESTACCT**, identifies the message sender. The format is alpha-numeric, left-justified, and padded on the right with blanks.

DESTTYPE

This field contains the value D, indicating the source identified by **DESTACCT** and **DESTUID** is a single user ID.

MSGNAME

This field contains the message name (or group name) that the message sender assigns. It is not validated by Information Exchange, but the message sender can use it to give a name to a message or to a group of messages. The format is alphanumeric, left-justified, and padded on the right with blanks.



NOTE: If there are messages remaining in the mailbox meeting the specified selection criteria after the completion of this receive command, the characters:

MORE, left justified and padded with blanks will be placed in this field. The following conditions must be true in order for the characters: MORE to be assigned:

- **TYPECMND** (of the receive messages command) is not **C**.
- **MAXMSGNO** (of the receive messages command) is not zeros or blank.
- **EXPAND** (of the receive messages command) is **4**.
- **MSGGRPIN** (of the long format header) is **E**.

MSGSEQN

This field contains a message sequence number that the message sender assigns. This field is not validated by Information Exchange. The format is numeric, right-justified, and padded on the left with zeros.

MSGNCLS

This network message class field determines certain special process classifications for this message.

This value: Indicates:

blank	A normal message without a CDH
T	A test-mode message without a CDH.
S	A normal message with CDH available.
R	A test-mode message with CDH available..

MSGUCLS

This field enables end users to indicate the type of data in a message. You can use it to indicate a printer form number or any other general classification as agreed upon by the end users of Information Exchange. The format is alphanumeric, left-justified, and padded on the right with blanks.

MSGCLASS

This field identifies the delivery class of this message. The format is alphanumeric, left-justified, and padded on the right with blanks.

This value: Indicates:

blank	Normal priority delivery.
P	High priority delivery
I	Express priority delivery.
A	Normal priority, requeued archive message.

MSGRCPTS

This field contains either a blank, indicating that no delivery acknowledgment was sent to the message sender, or the value **D**, indicating that a delivery acknowledgment was sent to the message sender.

MSGCHRG

This field contains a value that indicates how charges for the message are made.

This value: Indicates:

- | | |
|--------------|---|
| blank | That no charges were made. |
| 1 | That you, the receiver, are being charged for both receiver and transmitter message services. This is a collect message. |
| 5 | That you, the receiver, are being charged for the receiver's message services, and the sender is being charged for the transmitter's message service (split charges). |
| 6 | That the sender is being charged for both the receiver's and transmitter's message services (prepaid charges). |

MSGSEQO

This field contains a unique number (0 to 999999 and repeats, if necessary) that Information Exchange assigns to each message sent to a user ID. The format is numeric, right-justified, and padded on the left with zeros.

SYSTYPE

This field contains the value of **SYSTYPE** that was set by the sender's Session Start command. The format is alphanumeric, left-justified, and padded on the right with blanks.

SYSLEVEL

This field contains the value of **SYSLEVEL** that was set by the sender's Session Start command. The format is alphanumeric, left-justified, and padded on the right with blanks.

EXPAND

This field contains the value from **EXPAND** of the Receive Messages command. EXTRTN

EXTRTN

This is a reserved field; leave it blank.

MSGDATE

This field contains the date that the sender entered the message into the Information Exchange system. The format is numeric (YYMMDD), right-justified, and padded on the left with zeros.

MSGTIME

This field contains the time that the sender entered the message into the Information Exchange system. The format is numeric (HHMMSS), right-justified, and padded on the left with zeros.

MSGTZONE

This field indicates the type of date and time reference in **MSGDATE** and **MSGTIME**. The value is **L**, indicating your local time. Because the Information Exchange system references time internally to GMT, the value placed in **MSGTIME** and **MSGDATE** depends upon the value sent in the Session Start command in **TIMEZONE**.

DTBLTYP

This field, if **DESTTYPE** is **D**, identifies the table type of an alias table. Combined with **DTBLID**, this field uniquely defines the alias table in which to resolve the alias name created by combining **DESTACCT** and **DESTUID**. If an alias name was used, this field contains one of the following values:

This value: Indicates:

G	A global alias table.
O	An organizational alias table.
P	A private alias table.

If the sender is on a different system, the field contains the value **I**. If neither of these is the case, the field is blank.

DTBLID

This field, if **DESTTYPE** is the value **D**, identifies the table name of an alias table. Combined with **DTBLTYP**, this field uniquely defines the alias table in which to resolve the alias name created by combining **DESTACCT** and **DESTUID**. The format is alphanumeric, leftjustified, and padded on the right with blanks. If an alias was used, this field contains the name of the alias table. If the sender is on a different system and **DTBLTYP** is the value **I**, this field contains the ID of the sender's system. If neither of these is the case, the field is blank.

MSGTEXT

This field contains the text of the message.

Retrieve Library Member command

This command places a copy of a library member in your mailbox or in whatever mailbox you request. Information Exchange places the member in the mailbox as a message group. Library members can be directed to user mailboxes using the values you specify in the GET-DESTACCT and GET-DESTUSER fields. Charges are based on receive domain payment levels.

The copybook for this command is EXPLRTV.1

Table 66. Retrieve Library Member command

Column	Size	Name	Explanation	Value
1	1	GET-PASS	Pass-through indicator	4
2	19	GET-FILLER	Filler	
21	8	GET-COMMAND	Command	SDILRTV
29	8	GET-ACCOUNT	User's Account ID	Account ID
37	8	GET-USERID	User's user ID	User ID
45	8	GET-OWNER	Owning account ID	Account ID
53	8	GET-LIBNAME	Library name	Library name
61	8	GET-MEMBER	Member name	Member name
69	2	GET-MS GRETN	Message retention	00-99
71	8	GET-MS GNAME	Message name	User-defined
79	5	GET-MSGSEQN	Message sequence	User-defined
84	8	GET-MSGUCLS	Message user class	User class
92	1	GET-MSGCHRG	Message service charge	1, 3, 5, or 6
93	1	GET-MSGRCPTS	Message acknowledgement	blank, A - F, R
94	8	GET-DESTACCT	Destination account	Account or List
102	8	GET-DESTUSER	Destination user ID	Userid or blank
110	1	GET-DESTTYPE	Destination type	D or L
111	1	GET-DTBLTYPE	Alias table type	G, I, O, or P
112	3	GET-DTBLID	Alias table ID	Alias table ID

GET-PASS

Indicates if the command is defined to the command processor as a pass-through command or one supported by the command processor. The value must be 4.

GET-FILLER

Leave this field blank. Either it is not required by Expedite/CICS, or the value is supplied by Expedite/CICS and your application cannot override it.

GET-COMMAND

This field contains a command name of SDILRTV, which identifies this as the Retrieve Library Member command. This command retrieves a member from a library and places it in your mailbox.

GET-ACCOUNT

This field contains your account ID. The format is alphanumeric, left-justified, and padded on the right with blanks.

GET-USERID

This field contains your user ID. The format is alphanumeric, left-justified, and padded on the right with blanks.

GET-OWNER

This field contains a value that identifies the owner of the library specified by LIBNAME. The default value is the account to which you belong. The format is alphanumeric, leftjustified, and padded on the right with blanks.

GET-LIBNAME

This field contains the name of the library from which you want to retrieve the specified member. The format is alphanumeric, left-justified, and padded on the right with blanks.

GET-MEMBER

This field contains the name of the member you want to retrieve. The format is alphanumeric, left-justified, and padded on the right with blanks.

GET-MSGRETN

This field contains a value that specifies the number of days Expedite/CICS keeps the message group stored if it is not received by the destination. This field is used only for the first (or only) long message header of a message group. If this field does not contain valid numeric digits, or if it contains 00, Information Exchange supplies the system default value. The format is numeric.



NOTE: In the U.S., the default is 30 and the maximum value that may be specified is 180 days. Your system may differ.

GET-MSGNAME

This field is used in conjunction with **GET-MSGSEQN**, and shows up in the Information Exchange acknowledgments records. The format is alphanumeric, left-justified, and padded on the right with blanks. This field is not validated.

GET-MSGSEQN

This field is used, in conjunction with **GET-MSGNAME**, in the Message ID column of the Information Exchange Administration Services audit trail. The format is alphanumeric, leftjustified, and padded on the right with blanks. This field is not validated.

GET-MSGUCLS

This field may be used to specify a descriptor for selective message retrieval from the Information Exchange queue. The format is alphanumeric, left-justified, and padded on the right with blanks.

GET-MSGCHRG

This value in this field indicates to Expedite/CICS how the sender wants message charges to be paid. This field will be validated to verify it contains a value of blank, 0, or 1-6. If the value is blank or 0, it will default to 3. The Information Exchange charge values are listed below.

This code: Indicates that charges are paid by:

- | | |
|----------|--|
| 1 | The receiver |
| 3 | The receiver, if agreed to by the receiver, otherwise, the library owner pays. |
| 5 | The sender, if agreed to by the library owner, otherwise, the receiver pays. |
| 6 | The sender |

GET-MSGRCPTS

This field contains a value that indicates the type of acknowledgment messages you want to receive. The valid values are listed below.

This code: Indicates Information Exchange should:

- | | |
|---------------------|---|
| <u>blank</u> | Create no acknowledgements. |
| A | Create only purge acknowledgements. |
| D | Create only delivery acknowledgments, which are sent to the user when Information Exchange delivers the data to the library |
| E | Create both purge and delivery acknowledgments. The |

following acknowledgment codes are not supported in Expedite/CICS:

- **R:** Receipt acknowledgments, created and sent to a user when Information Exchange receives a message and reaches the recovery point with the sender
- **B, C, and F:** Associated with receipt acknowledgments.

For more information about getting acknowledgments with library commands, see “Understanding acknowledgments” on page 117.

GET-DESTACCT

This field contains the destination account ID of the mailbox in which you want the library member placed or, if **GET-DTBLTYPE** and **GET-DTBLID** are specified, the first 8 characters of the alias name. The field contains a destination account ID if the value in **GETDESTTYPE** is **D**. If the value in **GET-DESTTYPE** is **L**, this field contains the name of a list.

GET-DESTUSER

This field contains the destination user ID of the mailbox in which you want the library member placed. If the value in **GET-DESTTYPE** is **D**, this field contains the destination user ID or, if **GET-DTBLTYPE** and **GET-DTBLID** are specified, the last 8 characters of the alias name. If **GET-DESTTYPE** is **L**, the system ignores this field.

GET-DESTTYPE

The value in this field indicates the type of reference in the **GET-DESTACCT** and **GET-DESTUSER** fields.

This value: Indicates:

- D** **GET-DESTACCT** and **GET-DESTUSER** define a single destination or alias name, if **GET-DTBLTYPE** and **GET-DTBLID** are specified.
- L** **GET-DESTACCT** names a distribution list.

GET-DTBLTYPE

This field identifies an alias table type. Combined with **GET-DTBLID**, this field uniquely defines the alias table in which to resolve the alias name created by combining the values in **GET-DESTACCT** and **GET-DESTUSER**. This field contains a code which indicates whether this is a true Information Exchange address or an alias ID entry.

This value: Indicates:

- G** A global alias table.
- O** An organization (account) alias table.
- P** A private alias table.
- I** An intersystem address.

If you are sending to an account ID and user ID on a different system, use the value I.

If the alias table type is blank, the alias table ID must also be blank. If table type is not I or blank, the account ID and user ID fields concatenation must contain a value that identifies the alias name.

GET-DTBLID

This field identifies the name of an Information Exchange alias table. If the value in **GETDTBLTYPE** is **I**, this field identifies the recipient's system.

If **GET-DTBLTYPE** contains a value, this field must not be blank.

Retrieve Library Member response

Expedite/CICS returns the standard Expedite/CICS response to the user program, using the EXPCRSP format. For information about the response COMMAREA format, see "Command processor responses" on page 63.

This value: Indicates:

- HI000** The command completed successfully.
- HIxxx** The data sent to the command processor contained an error. For a list of error messages and recommended actions, see *Expedite/CICS Messages*.

Retrieve Library Member CDH command

This command will retrieve CDH information for a library member. The copybook for this command is EXPLCDH. 1

Table 67. Retrieve Library Member CDH command

Column	Size	Name	Explanation	Value
1	1	CDH-PASS	Pass-through indicator	4
2	8	CDH-TSQNAME	TSQueue name	Queue name
10	11	CDH-FILLER	Filler	
21	8	CDH-COMMAND	Command	SDILCDH
29	8	CDH-ACCOUNT	User's account ID	Account ID
37	8	CDH-USERID	User's user ID	User ID
45	8	CDH-OWNER	Owning account ID	Account ID
53	8	CDH-LIBNAME	Library name	Library name
61	8	CDH-MEMBER	Library member	Library member

CDH-PASS

Indicates if the command is defined to the command processor as a pass-through command or one supported by the command processor. The value must be 4.

CDH-TSQNAME

This field identifies the temporary storage queue file name that will contain the data upon successful completion of the command. The data will be in the format identified in the CDH described in copybook EXPCCDH.

CDH-FILLER

Leave this field blank. It is either not required by Expedite/CICS, or the value is supplied by Expedite/CICS and your application cannot override it.

CDH-COMMAND

This field contains a command name of SDILCDH, which identifies this as a Retrieve Library Member CDH command.

CDH-ACCOUNT

This field contains your account ID. The format is alphanumeric, left-justified, and padded on the right with blanks.

CDH-USERID

This field contains your user ID. The format is alphanumeric, left-justified, and padded on the right with blanks.

CDH-OWNER

This field identifies the library owner. The default value is the account to which you belong. The format is alphanumeric, left-justified, and padded on the right with blanks. If the field is blank, the value in **CDH-ACCOUNT** is assigned.

CDH-LIBNAME

This field specifies the name of the library from which you want the CDH. The format is alpha-numeric, left-justified, and padded on the right with blanks.

CDH-MEMBER

This field specifies the name of the library member from which you want the CDH. The format is alphanumeric, left-justified, and padded on the right with blanks.

Retrieve Library Member CDH response

Expedite/CICS returns the standard Expedite/CICS response to the user program, using the EXPCRSP format. For information about the response COMMAREA format, see “Command processor responses” on page 63.

This value:	Indicates:
HI000	The command completed successfully.
HIxxx	The data sent to the command processor contained an error. For a list of error messages and recommended actions, see <i>Expedite/CICS Messages</i> .

Send file command

Use the Send File command to send data to Information Exchange through the command processor. The name of the Send File command COMMAREA is EXPSNDF. Using EXPSNDF, you can send data from a temporary storage queue, an entry sequence VSAM data set, or a transient data queue.

The copybook for this command is EXPSNDF.

Send File command COMMAREA format

To issue a Send File command, pass the following COMMAREA format and values to the command processor. 1

Table 68. Send File command COMMAREA format

Column	Size	Name	Explanation	Value
1	1	SF-PASS	Pass-through indicator	Zero or 4
2	8	SF-FNAM	File name	File name
10	2	SF-FTYPE	File type.	TS, TD, VS
12	1	SF-DTYPE	Data type	E, A, B, O
13	1	SF-FDISP	File disposition	N, H, P
14	7	SF-FILLER	Filler	blank
21	8	SF-CCMD	Command name	EXPSNDF
29	8	SF-CACCT	User's account	Account name
37	8	SF-CUSER	User ID	User ID name
45	8	SF-CSKEY	Session access key	blank
53	8	SF-CDACCT	Destination account	Destination account
61	8	SF-CDUSER	Destination user ID	Destination user ID
69	1	SF-CDTYPE	Destination type	D or L
70	8	SF-CUMSGC	Message user class	Message user class
78	1	SF-CRCPT	Receipt indicator	A-F, blank, or R
79	1	SF-CLTYP	Alias table type	G, I, O, P, or blank
80	3	SF-CLID	Alias table id	Alias table ID for SFCDACCT and SF-CDUSER
83	1	SF-C VFY	Verify before sending	Y, N, or F
84	2	SF-CMSRTN	Undelivered retention	00-99
86	8	SF-CCDH	CDH overrides	TSQ name
94	79	SF-CDESC	File description	Free format

Table 68. Send File command COMMAREA format

Column	Size	Name	Explanation	Value
173	8	SF-MSGNAME	Unique message name	User defined
181	5	SF-MSGSEQN	Message sequence number	User defined
186	1	SF-MSGCLASS	Message delivery class	P, I, or blank
187	1	SF-MSGCHRG	Message service charge	1-6
		 NOTE: You can use the fields above this note for pass-through values of zero or 4. The fields below this note can be used only when the pass-through value is 4, with the exception of SFCSNDSELR and SF=COMPRESS, which can be used if the pass-through value is 0 or 4.		
188	8	SF-UNIQUE	Unique identifier	User defined
196	8	SF-REJECT	Reserved for future use	
204	8	SF-UPROG	Send completion notification	User program or transaction
212	2	SF-UPROGTYP	Type of user program	PG or TR
214	4	SF-CALLID	Reserved for future use	
218	50	SF-USER-AREA	User application data	User defined data area
268	1	SF-CSNDSELR	Selective receive	Y or N
269	1	SF-COMPRESS	Data compression	Y, N, or T
270	232	SF-FILLER	Reserved for future use	

This value: Means:

>**blank**< Expedite/CICS supplies the field value. You can use the default value in your application, or your application can override it.

blank Either the field is not required by Expedite/CICS, or the value is supplied by Expedite/CICS and your application cannot override it.

The descriptions of the COMMAREA fields for sending data to Information Exchange are:

SF-PASS

This field indicates whether the command being submitted is defined to the command processor as a pass-through command or one supported by the command processor. For the Send File command, the value must be zero or 4. If the value is zero, you may use COMMAREA fields 1 - 187; if the value is 4, you may also use the fields beyond 187.

SF-FNAM

This field identifies the name of the file that is being sent.

SF-FTYPE

This field indicates the type of file being sent:

This value: Means:

TS	Temporary storage
TD	Transient data
VS	VSAM ESDS

SF-DTYPE

This field indicates the type of data being sent:

This value: Means:

E	EDI
A	CRLF
B	LL
O	Other

The command processor uses this indicator to process the data being sent. Data types **X** (X12), **U** (UCS), and **T** (EDIFACT or UN/TDI) used in previous releases are still valid but the recommended value for all EDI formatted data is **E**. For more information, see “Send processing considerations” on page 82.

SF-FDISP

This field indicates how to process the file:

This value: Means:

N	Normal processing by Expedite/CICS.
H	Place the file in a hold status to be sent later. To have the file sent to Information Exchange, you must release it later with a Process command.
P	Send this priority file before any unsent messages or files.



NOTE: **P** is valid only if you are using asynchronous send processing. If you use any other values in this field, the value defaults to N.

SF-FILR

Leave this field blank. Either it is not required by Expedite/CICS, or the value is supplied by Expedite/CICS and your application cannot override it.

SF-CCMD

This field identifies the command name to the command processor so it can perform the proper processing. It must be EXPSNDF for the Send File command.

SF-CACCT

This field contains your account ID and is used with the **SF-CUSER** field to identify the user sending the file. The format is alphanumeric, left-justified, and padded on the right with blanks.

SF-CUSER

This field contains your user ID and is used with the **SF-CACCNT** field to identify the user sending the file. The format is alphanumeric, left-justified, and padded on the right with blanks.

SF-CSKEY

Leave this field blank. Either it is not required by Expedite/CICS, or the value is supplied by Expedite/CICS and your application cannot override it.

SF-CDACCT

If values are specified for **SF-CLTYPE** and **SF-CLID**, this field contains the first 8 characters of an alias name. Otherwise, this field contains either a destination account ID (if **SF-CDTYPE** contains **D**) or the name of a list (if **SF-CDTYPE** contains **L**). The format is alphanumeric, left-justified, and padded to the right with blanks.

SF-CDUSER

If values are specified for **SF-CLTYPE** and **SF-CLID**, this field contains the last 8 characters of an alias name. Otherwise, this field contains either the destination user ID (if **SF-CDTYPE** contains **D**). This field is ignored if **SF-CDTYPE** contains **L**. The format is alphanumeric, left-justified, and padded on the right with blanks.

SF-CDTYPE

The value in this field indicates the type of reference in **SF-CDACCT** and **SF-CDUSER**.

This value: Indicates:

- | | |
|----------|---|
| D | Indicates the SF-CDACCT and SF-CDUSER fields contain the destination. |
| L | Indicates the SF-CDACCT field contains the destination list name and the SF-CDUSER field contains blanks. |

SF-CUMSGC

You can, optionally, use this field to specify a user message classification. The value in this field can be used by a file recipient to selectively retrieve this file by identifying the user message class to retrieve. If this field is left blank, Expedite/CICS will generate a default user class for EDI data; #E2 for X12, #EC for UCS, #EU for UN/TDI, and #EE for EDIFACT data.

SF-CRCPT

This field indicates the type of acknowledgment messages you want to receive. The valid values are listed below.

This code: Indicates Information Exchange should create:

- | | |
|--------------|---------------------|
| blank | No acknowledgements |
|--------------|---------------------|

This code: Indicates Information Exchange should create:

- R** Only a receipt acknowledgment when Information Exchange receives the message and reaches the recovery point with the sender.
- D** Only a delivery acknowledgment when Information Exchange delivers the message to its destination and reaches a subsequent level of delivery-related processing with the recipient.
- B** Both receipt and delivery acknowledgments.
- A** Only a purge acknowledgment, which can be one of the following:
- When the message reaches its storage time limit and is purged from the receiver's queue. If you specify a retention time in RFCMSRTN, this is used as the storage time limit; otherwise, Information Exchange uses the default time.
 - When the message was canceled by the sender, the receiver, a service administrator, or a support representative.
- C** Both a receipt and a purge acknowledgment.
- E** Either a purge or a delivery acknowledgment.
- F** A receipt acknowledgment, and either a purge or a delivery acknowledgment.

SF-CLTYP

This field identifies the table type of an alias table if **SF-CDTYPE** is **D**. Combined with **SF-CLID**, this field uniquely defines the alias table in which to resolve the alias name created by combining **SF-CDACCT** and **SF-CDUSER**. If you are sending to an alias, enter the alias table type (**G**, **O**, or **P**) in this field. If you are sending to a user on a different system, set the value to **I**. If you are not sending to an alias table or to a user on a different system, leave this field blank.

SF-CLID

This field identifies the table name of an alias table if **SF-CDTYPE** contains **D**. Combined with **SF-CLTYP**, this field uniquely defines the alias table in which to resolve the alias name created by combining **SF-CDACCT** and **SF-CDUSER**. The format is alphanumeric, leftjustified, and padded on the right with blanks. If you are using an alias table, enter its name in this field. If you are sending to a user on a different system, and **SF-CLTYPE** is **I**, enter the ID of the recipient's system in this field. If you are not sending to an alias table, nor to a user on a different system, leave this field blank.

SF-C VFY

Use this field to enter a code that will validate a destination address before sending a file. Expedite/CICS issues an Information Exchange Probe command to verify addresses as described below.

- Account IDs, user IDs, and alias names are checked to see if they exist on Information Exchange.
- If a distribution list exists on Expedite/CICS, it is uploaded to Information Exchange and then the file is sent. Because there is NO check to verify that IDs in an Expedite/CICS distribution list are valid, it is recommended that you:

- Use Information Exchange Administration Services to define the list.
 - Do not use **Verify before send** for Expedite/CICS distribution lists.
 - Use the Expedite/CICS List Verify command function as described in “List Verify command” on page 215.
- If a list is a permanent list on Information Exchange, the PROBE command will verify its existence. IDs in such a list are usually valid because Information Exchange does not allow creation of an Information Exchange list with invalid values, unless the ID is on another system.

This code: Tells Expedite/CICS to:

- N** Send the file without verifying the address. If the destination is not valid, a system error message will be placed in your mailbox. Expedite/CICS marks the file as SENT.
- Y** Validate the address; if the address is known to Information Exchange, the file is sent. If the Probe command response is negative or deferred, Information Exchange does not send the file, and returns an error message. A deferred response means Information Exchange could not immediately verify the address because, for example, the destination address is on a different system.
- F** Validate the address. If the Probe response is deferred, as explained under code **Y** above, Expedite/CICS sends the file.



NOTE: Verifying destination addresses before sending increases processing time. If you consistently send to a destination you have already validated, set the value of Verify before send to N (No).

SF-CMSRTN

This field allows you to specify to Information Exchange how long (up to 99 days) to retain an undelivered file. If you leave this field blank or specify 00, it defaults to the value specified for your system; in the U.S., this is 30 days.

SF-CCDH

This field allows you to provide additional descriptive information to Information Exchange about this file by placing the name of the temporary storage queue that contains that information in this field. The format of the common data header is described in “Information Exchange Common Data Header (CDH)” on page 132. For more information, see Chapter 4, “Working with additional Expedite/CICS application features.”

SF-CDESC

This field allows you to describe the file being sent in a 79-byte free format field. You can place the description here or in the common data header description.

SF-MSGNAME

This field can be used to name a message or a group of messages. If the message is the first in a group, this field names the entire group. This field is not validated by Information Exchange. The format is alphanumeric, left-justified, and padded on the right with blanks. This field is also referenced in Information Exchange acknowledgments and audit trails.

SF-MSGSEQN

This field can be used to assign a message control number to a message or to number messages within a message group. This field is not validated by Information Exchange. The format is alphanumeric, left-justified, and padded on the right with blanks. This field is also referenced in Information Exchange acknowledgments and audit trails.

SF-MSGCLASS

This field may be used to assign a delivery priority to a message.

This code: Indicates:

blank	Normal-priority.
P	High priority
I	I Express delivery. Express-delivery messages are delivered only if the destinations are currently receiving messages from Information Exchange. If this option is used and the message cannot be immediately delivered (the destination does not have an active receive), the message is discarded and a notification is placed in the sender's mailbox.

SF-MSGCHRG

The value in this field indicates to Information Exchange how the sender wants message charges to be paid; refer to the *Information Exchange Interface Programming Guide* for details about message charge codes. For a message group, the charge method requested in the first message within the group determines the charge method for the entire group. If the value is blank or **0**, it will default to **3**. The Information Exchange charge values are listed below.

This code: Indicates that charges are paid by:

1	The receiver.
3	The receiver, if agreed to by the receiver; otherwise, the library owner pays.
5	The sender, if agreed to by the library owner; otherwise, the receiver pays.
6	The sender.

SF-UNIQUE

The value in this field specifies a unique identifier for a message. When sending EDI data, the value applies to all interchanges within the file. The value is placed in the **CDH-UNIQUE** field and passed to Information Exchange. The value is returned in the completion notification COMMAREA and Information Exchange acknowledgments. If not assigned, Expedite/CICS creates a value, as described in "UNIQUEID assignment" on page 118.

SF-REJECT

This field is reserved for future use; leave it blank. When enabled, it will be used when the value in the SF-PASS field is 4.

SF-UPROG

The value in this field specifies a user program or transaction to use for send completion notification. The program will be linked to or the transaction will be started, if the data is being sent synchronously or asynchronously. For more information, see “Expedite/CICS completion-notification acknowledgments” on page 122. When Expedite/CICS has successfully sent the data or has encountered an error that makes sending the data impossible, the user program will be invoked. It will be when the value in the **SF-PASS** field is **4**. This field is used in conjunction with **SF-UPROGTYP**.

SF-UPROGTYP

The value in this field specifies whether a user program will be linked or a transaction will be started. It will be used when the value in the **SF-PASS** field is **4**. Valid values are: **PG** (program) and **TR** (transaction).

SF-CALLID

This field is reserved for future use; leave it blank. When enabled, it will be used when the value in the **SF-PASS** field is **4**.

SF-USER-AREA

Use this field to specify a user area that will be passed by Expedite/CICS to the user programs in the COMMAREA. This field will be used when the value in the **SF-PASS** field is **4**.

SF-CSNDSELR

This field allows you to specify to Information Exchange whether or not the recipient of this message must specify selective search criteria for the message to be delivered. Valid values are **Y** and **N**. If **Y** is specified, one of the following receive search criteria must be used.

- Sender's address
- User message class
- Message key

The default is **N**, indicating the message can be received without specifying the selective receive search criteria.

SF-COMPRESS

You can control data compression with the SF-COMPRESS parameter. The values allowed are as follows:

This code: Indicates:

- | | |
|----------|---|
| Y | Compress |
| N | Do not compress (Default). |
| T | Use the lookup table. If the sender/receiver pair is found in the table and Compress=Y in the table, then compress. If Compress=N or it is not found, then do not compress. |

Send file command

Logical length (LL) type data (**File Type B**) is not supported by the Comm-Press product. Expedite/CICS returns a message if compression is attempted with this type of data.

SF-FILLER

This field is reserved for future use; leave it blank. When enabled, it will be used when the value in the **SF-PASS** field is **4**.

Send File response

After your application issues a Send File command, the command processor returns one of the following in the RSPCODE field of the EXPCRSP COMMAREA. See “Command processor responses” on page 63 for the response COMMAREA formats.

This response: **Means:**

HI000 This will be returned if no errors occur.

HI001 This response only appears in the case of severe error, indicated by SDIERR. The response from Information Exchange is placed in the **RSPDATA** field of the response COMMAREA format. Your application should interrogate this Information Exchange response code to determine what action, if any, your application should take as a result of the response returned. See “SDIERR messages” on page 66 for more information.

This response:	Means:
HIxxx	The data your application sent to the command processor contains an error. See <i>Expedite/CICS Messages</i> for a list of error messages and recommended corrective actions.

Possible errors for this command include:

- HI421** The session profile does not exist because the user has not established an active session. One example of why this would happen is that the Session Start command was not processed correctly.
- HI432** Expedite/CICS received a response from Information Exchange that the destination address does not exist. Your message is not sent.
- HI433** Expedite/CICS received a response from Information Exchange that the trading partner list prevents you from sending to this destination. Your message is not sent.
- HI435** **SF-COMPRESS** was set to **Y** or **T** and **SF-DTYPE** was set to **B**. **LL** type data is not supported with compression.
- HI436** **SF-COMPRESS** was set to **T**. Expedite/CICS received an unknown return code from the Lookup table search program (LKUPTBLC). Your message is not sent.
- HI437** **SF-COMPRESS** was set to **Y** or **T** and **SF-DTYPE** was set to a value other than **A**, **E**, or **O**.
- HI439** Data compression was requested and a non-zero return code was returned by the compression program (COMPCICS). Your message is not sent.
- HI968** **SF-COMPRESS=T** was requested. Expedite/CICS is unable to load the Lookup table search program (LKUPTBLC). Your message is not sent.
- HI969** Data compression was requested. Expedite/CICS is unable to load the compression program (COMPCICS). Your message is not sent.



NOTE: When using asynchronous send processing (See “Process send data” on page 26), Expedite/CICS executes restart and recovery procedures to recover from the following error codes until the message is sent successfully.

This response:	Means:
HI461	UNABLE TO ESTABLISH A SESSION WITH INFORMATION EXCHANGE.
HI462	SESSION WITH INFORMATION EXCHANGE HAS BEEN LOST.
HI463	RECEIVE RESTART ALREADY PENDING.
HI464	SEND CHECKPOINT NUMBERS OUT OF SYNCHRONIZATION.
HI467	UNEXPECTED COMMIT RESPONSE CODE > 07, SEE IE ERROR CODES.
HI500	AN ERROR OCCURRED WHEN RECEIVING THE SEND COMMIT RESPONSE.
HI509	UNABLE TO SEND THE MESSAGE TO IE.

**NOTE:**

1. When using synchronous send and any of the above errors are returned, the command processor returns the error to the calling application and deletes the data from Expedite/CICS.
2. For messages HI461, HI462, HI463, HI500, HI504, HI505, and HI509, the calling application may perform a new session start and reissue the send command.
3. For message HI461, the calling application may attempt to reacquire the system connection before performing a new session start and reissuing the send command.

Your application can display the message on panels for the user to follow up on, or you can design your application to check for a message, and then determine the action that the user should take.

Session End command

Use the Session End command to end an Information Exchange session. When this command is issued, Expedite/CICS first checks for in-process Information Exchange functions, such as send and receive requests. Active single receives are allowed to complete, and all active continuous receives are stopped before the Session End command is sent to Information Exchange.



NOTE: Depending on what commands are active, it may take some time for a Session End command to complete. You can verify that a Session End command has been issued and processed in Information Exchange by linking to the session exit described in “Session Exit” on page 128. When the session end indicator is 1, the session has been issued, but not processed by Information Exchange. When the indicator is 0, the session has been ended.

The copybook for this command is EXP SEND.

Session End command COMMAREA format

To issue a Session End command, pass the following COMMAREA format and values to the command processor. 1

Table 69. Session End command COMMAREA format

Column	Size	Name	Description	Value
1	1	SEPASS	Pass-through indicator	zero
2	8	SEQNAM	TSQ name	blank
10	2	SEPAD	Filler	blank
12	1	SEDTYPE	Data type	blank
13	8	SEFILR	Filler	blank
21	8	SENAME	Command name	SDISEND
29	8	SEACCT	Account ID	Account name
37	8	SEUSER	User ID	User ID name
45	8	SEKEY	Session access key	blank
53	8	SERSP	Response name	blank
61	5	SERSPCD	Response code	blank
66	1	SEEXP	Expansion indicator	blank

This value: Means:

>blank< Expedite/CICS supplies the field value. You can use the default value in your application, or your application can override it.

blank The field is either not required by Expedite/CICS, or the value is supplied by Expedite/CICS and your application cannot override it.

Your application needs to provide only the following data to the command processor to send a Session End command:

- Pass-through indicator
- Command name
- Account ID
- User ID

The descriptions of the fields you place in the COMMAREA are:

SEPASS

This field indicates whether the command being submitted is defined to the command processor as a pass-through command or one supported by the command processor. For the Session End command, the value must be zero.

SEQNAM

Leave this field blank. Either it is not required by Expedite/CICS, or the value is supplied by Expedite/CICS and your application cannot override it.

SEPAD

Leave this field blank. Either it is not required by Expedite/CICS, or the value is supplied by Expedite/CICS and your application cannot override it.

SEDTYPE

Leave this field blank. Either it is not required by Expedite/CICS, or the value is supplied by Expedite/CICS and your application cannot override it.

SEFILR

Leave this field blank. Either it is not required by Expedite/CICS, or the value is supplied by Expedite/CICS and your application cannot override it.

SENAME

This field identifies the command name to the command processor so it can perform the proper processing. For this command, it must be SDISEND.

SEACCT

This field is used with the SEUSER field to identify the user. The format is alphanumeric, left-justified, and padded on the right with blanks.

SEUSER

This field is used with the SEACCT field to identify the user. The format is alphanumeric, left-justified, and padded on the right with blanks.

SEKEY

Leave this field blank. Either it is not required by Expedite/CICS, or the value is supplied by Expedite/CICS and your application cannot override it.

SERSP

Leave this field blank. Either it is not required by Expedite/CICS, or the value is supplied by Expedite/CICS and your application cannot override it.

SERSPCD

Leave this field blank. Either it is not required by Expedite/CICS, or the value is supplied by Expedite/CICS and your application cannot override it.

SEEXP

Leave this field blank. Either it is not required by Expedite/CICS, or the value is supplied by Expedite/CICS and your application cannot override it.

Session End response

When your application sends a Session End command to the command processor, the command processor forwards the command to Information Exchange. When Information Exchange returns a Session End response, the command processor checks the response to determine whether the session ended successfully.

The command processor returns one of the following values in the EXPCRSP COMMAREA after your application sends the Session End request. See “Command processor responses” on page 63 for the response COMMAREA formats.

This response: Means:

- | | |
|--------------|--|
| HI000 | The command processor has validated the data your application sent. The command processor will send the Session End command when it completes all the active functions. |
| HIxxx | The data that your application sent to the command processor contains an error. See <i>Expedite/CICS Messages</i> , for a list of error messages and recommended corrective actions. Possible errors for this command include: |
| HI421 | You do not have an active session with Information Exchange. |

Session Inquiry command

Use the Session Inquiry command to get information about a specific Information Exchange session, such as when the session started and how many messages have been sent and received.



NOTE: The Session Inquiry command is command-processor supported and can be issued from the Display Application. Because this was not true in earlier Expedite/ CICS versions, provision has been made so this command can still be issued using the Passthrough option. Existing applications that use it this way are not affected.

Session Inquiry command COMMAREA format

To issue a Session Inquiry command, pass the following COMMAREA format and values to the command processor.

Table 70. Session Inquiry command COMMAREA format

Column	Size	Name	Description	Value
1	1	SIPASS	Pass-through indicator	Zero
2	8	SICFNAM	Filler	blank
10	2	SICFTYP	Filler	blank
12	1	SICDTYPE	Filler	blank
13	8	SICPAD2	Filler	blank
21	8	SICCOMMAND	Command name	SDIINQS
29	8	SICACCNTNO	Account name	Account name
37	8	SICUSERID	User ID	User ID name
45	8	SICSESSKEY	Session access key	blank
53	8	INQSTRID	Inquiry response command	Inquiry response
61	1	INQTYPE	Inquiry type	L or S
62	1	EXPAND	Expansion indicator	1

Field descriptions are provided below.

INQSTRID

The value of this field is placed in the first 8 characters of the Session Inquiry response. The format is alphanumeric, left-justified, and padded on the right with blanks.

INQTYPE

The value in this field determines the extent of the information returned in response to this command.

This value: Indicates:

- L** A long-form response is requested. See Table 70 below for the format of this response.
- S** A short-form response is requested. See Table 72 on page 272 for the format of this response.

EXPAND

This field contains a command expansion-level indicator that must be 1. Invalid values default to blank.

Session Inquiry response

The Session Inquiry command produces an immediate response, which is returned to the calling program. The most complete collection of data available about an Information Exchange session is the long-format response. This is the format of the long-format Session Inquiry response:1

Table 71. Session Inquiry command long-format response

Column	Size	Name	Description
1	8	COMMAND	Command name
9	8	ACCNTNO	Account ID
17	8	USERID	User ID
25	8	SESSKEY	Session access key
33	1	INQTYPE	Inquiry type
34	6	INQDATE	Inquiry date
40	6	INQTIME	Inquiry time
46	6	SESSDATE	Session start date
52	6	SESSTIME	Session start time
58	6	SESSLEN	Session duration
64	6	SNDTOT	Total SDISNDM commands sent
70	2	ACTVRCV	Total SDIRCVM commands active
72	6	RCVTOT	Total messages received
78	6	IDLETIME	Total time idle
84	1	SYS WAIT	Pace/Commit response indicator
85	6	SNDPROC	SDISNDM commands processed
91	6	SNDAOK	SDISNDM commands accepted
97	6	SNDREJ	SDISNDM commands rejected

Table 71. Session Inquiry command long-format response

Column	Size	Name	Description
103	6	RCVDATA	Data messages received.
109	6	RCVSERV	Service messages received
115	6	RCVOTHR	Other messages received
121	5	LSTSNDP	Last send checkpoint number
126	5	LSTRCVCP	Last receive checkpoint number
131	29	LSTMSGS	Last data message sent
160	30	LSTMSGR	Last data message received
190	1	EXPAND	Expansion indicator

If you do not need all of this data, you may request an abbreviated short-format Session Inquiry response, shown in Table 72.1

Table 72. Session Inquiry command short-format response

Column	Size	Name	Description
1	8	COMMAND	Command name
9	8	ACCNTNO	Account ID
17	8	USERID	User ID
25	8	SESSKEY	Session access key
33	1	INQTYPE	Inquiry type
34	6	INQDATE	Inquiry date
40	6	INQTIME	Inquiry time
46	6	SESSDATE	Session start date
52	6	SESSTIME	Session start time
58	6	SESSLEN	Session duration
64	6	SNDTOT	Total SDISNDM commands sent
70	2	ACTVRCV	Total SDIRCVM commands active
72	6	RCVTOT	Total messages received
78	6	IDLETIME	Total time idle
84	1	SYS WAIT	Pace/Commit response indicator
85	1	EXPAND	Expansion indicator

The descriptions of the fields returned to you in the response are:

COMMAND

This field contains the value from the **INQSTRID** field of the Session Inquiry command that invoked this message. The format is alphanumeric, left-justified, and padded on the right with blanks.

ACCNTNO

This field is used with the **USERID** field to identify the user. The format is alphanumeric, left-justified, and padded on the right with blanks.

USERID

This field is used with the **ACCNTNO** field to identify the user. The format is alphanumeric, left-justified, and padded on the right with blanks.

SESSKEY

This field contains the value sent to your system in the Session Start response. The format is alphanumeric, left-justified, and padded on the right with blanks.

INQTYPE

The value in this field indicates the format of this response.

This value: Indicates:

L Long format

S Short format

INQDATE

This field contains the date the inquiry was processed. The format is numeric (YYMMDD), right-justified, and padded on the left with zeros.

INQTIME

This field contains the time the inquiry was processed. The format is numeric (HHMMSS), right-justified, and padded on the left with zeros.

SESSDATE

This field contains the date the session was started. The format is numeric (YYMMDD), right-justified, and padded on the left with zeros.

SESSTIME

This field contains the time the session was started. The format is numeric (HHMMSS), right-justified, and padded on the left with zeros.

SESSLN

This field contains the duration of this session. The format is numeric (HHMMSS), right-justified, and padded on the left with zeros.

SNDTOT

This field contains the total number of Send Message command message segments received by Information Exchange for this session. The format is numeric, right-justified, and padded on the left with zeros.

ACTVRCV

This field contains the total number of currently active Receive Message commands for this session. The format is numeric, right-justified, and padded on the left with zeros.

RCVTOT

This field contains the total number of message segments sent to the user during the current session as a result of Receive Message commands. The format is numeric, right-justified, and padded on the left with zeros.

IDLETIME

This field contains the time lapse since the last message transfer activity (receipt of a Send Message command, output of a message to satisfy a Receive Message command, or a Pace or Commit command) in the current session. The format is numeric (HHMMSS), rightjustified, and padded on the left with zeros.

SYS WAIT

This field contains a value indicating whether the session is waiting for a Commit response, a Pace response, or neither.

This code: Indicates that Information Exchange:

P	Is waiting for a Pace response from your user ID
C	Is waiting for a Commit response form your user ID
blank	Is not waiting for either the Pace or Commit response.

SNDPROC

This field contains the total number of Send Message commands (complete messages, not message segments) processed by Information Exchange for this session. Send Message commands are processed only after they have reached a point of recovery. The format is numeric, right-justified, and padded on the left with zeros.

SNDAOK

This field contains the total number of Send Message commands (complete messages, not message segments) processed and accepted for delivery service by Information Exchange for this session. The format is numeric, right-justified, and padded on the left with zeros.

SNDREJ

This field contains the total number of Send Message commands (complete messages, not message segments) processed but rejected by Information Exchange for this session. The format is numeric, right-justified, and padded on the left with zeros.

RCVDATA

This field contains the total number of user data messages (complete messages, not message segments) sent to the user as a result of Receive Message commands during the current session. The format is numeric, right-justified, and padded on the left with zeros.

RCVSERV

This field contains the total number of Information Exchange messages (complete messages, not message segments) sent to the user as a result of Receive Message commands during the current session. The format is numeric, right-justified, and padded on the left with zeros.

RCVOTHR

This field contains the total number of other messages queued to the user as a result of Information Exchange commands, such as Session Inquiry commands, during the current session. The format is numeric, right-justified, and padded on the left with zeros.

LSTSNDCP

This field contains the last send checkpoint established with Information Exchange during the current session. The format is numeric, right-justified, and padded on the left with zeros.

LSTRCVCP

This field contains the last receive checkpoint established with Information Exchange during the current session. The format is numeric, right-justified, and padded on the left with zeros.

LSTMSG

This field contains the values of **DESTACCT**, **DESTUID**, **MSGNAME**, and **MSGSEQN** from the last Send Message command received by Information Exchange during the current session. The format is alphanumeric, left-justified, and padded on the right with blanks.

LSTMSGR

This field contains the value of the network message identification (an internal control field for Information Exchange) and **MSGSEQO** in the last message sent in response to a Receive Message command during the current session. The format is alphanumeric, left-justified, and padded on the right with blanks.

EXPAND

This field contains the value from the **EXPAND** field of the Session Inquiry command.

Session Start command

To successfully communicate with Information Exchange, your application must establish an active Information Exchange session. To start an Information Exchange session, use the Session Start command.

The copybook for this command is EXPSSTA.

Session Start command COMMAREA format

To issue a Session Start command, pass the following COMMAREA format and values to the command processor. 1

Table 73. Session Start command COMMAREA format

Column	Size	Name	Description	Value
1	1	S SPAS S	Pass-through indicator	Zero
2	8	SSQNAM	Temporary storage queue name	blank
10	2	SSPAD	Filler	blank
12	1	SSDTYPE	Data type	blank
13	8	SSFILR	Filler	blank
21	8	SSNAME	Command name	SDISSTA
29	8	SSACCNT	Account ID	Account name
37	8	SSUSER	User ID	User ID name
45	8	SSPWD	User password	Password
53	8	SSNPWD	New password of user	optional
61	8	SSRSP	Response name	blank
69	8	SSTYP	System type	blank
77	4	SSLVL	System level	blank
81	1	SSRECOV	Recovery level	blank, A, or S
82	5	SSMXMSG	Maximum message size	blank
87	5	SSMXMSGP	Maximum messages between Commit requests	blank
92	8	SSPCMD	Commit command name	blank
100	8	SSREST	Reset indicator	blank
108	5	SSSCHKP	Send checkpoint indicator	blank
113	5	SSRCHKP	Receive checkpoint indicator	blank

Table 73. Session Start command COMMAREA format

Column	Size	Name	Description	Value
118	5	SSTZONE	Time zone	>blank<
123	1	SSEXP	Expansion indicator	blank

This value: Means:

>blank< Expedite/CICS supplies the field value. You can use the default value in your application, or your application can override it.

blank The field is either not required by Expedite/CICS, or the value is supplied by Expedite/CICS and your application cannot override it.

Your application needs to provide only the following data to the command processor to send a Session Start command:

- Pass-through indicator
- Command name
- Appropriate account name
- User ID
- Password

The descriptions of the fields you place in the COMMAREA are:

SSPASS

This field indicates whether the command being submitted is defined to the command processor as a pass-through command or one supported by the command processor. For the Session Start command, the value must be zero.

SSQNAM

Leave this field blank. Either it is not required by Expedite/CICS, or the value is supplied by Expedite/CICS and your application cannot override it.

SSPAD

Leave this field blank. Either it is not required by Expedite/CICS, or the value is supplied by Expedite/CICS and your application cannot override it.

SSDTYPE

Leave this field blank. Either it is not required by Expedite/CICS, or the value is supplied by Expedite/CICS and your application cannot override it.

SSFILR

Leave this field blank. Either it is not required by Expedite/CICS, or the value is supplied by Expedite/CICS and your application cannot override it.

SSNAME

This field identifies the command name to the command processor so it can perform the proper processing. For this command, it must be SDISSTA.

SSACCT

This field is used with the **SSUSER** field to identify the user. The format is alphanumeric, left-justified, and padded on the right with blanks.

SSUSER

This field is used with the **SSACCT** field to identify the user. The format is alphanumeric, left-justified, and padded on the right with blanks.

SSPWD

This field contains your Information Exchange access password (not to be confused with the LOGON password). It is used with **SSACCT** and **SSUSER** to identify the user. The format is alphanumeric, left-justified, and padded on the right with blanks.

SSNPWD

This field contains a new password for the next session, or blanks if the same password is to be used. A new password becomes effective only after the session terminates with a session end response code of 00000 (normal session end). The format is alphanumeric, left-justified, and padded on the right with blanks.

SSRSP

Leave this field blank. Either it is not required by Expedite/CICS, or the value is supplied by Expedite/CICS and your application cannot override it.

SSTYP

Leave this field blank. Either it is not required by Expedite/CICS, or the value is supplied by Expedite/CICS and your application cannot override it.

SSLVL

Leave this field blank. Either it is not required by Expedite/CICS, or the value is supplied by Expedite/CICS and your application cannot override it.

SSRECOV

The value in this field indicates the send processing mode.

This code: Indicates send commands will be processed:

- | | |
|----------|--|
| A | Asynchronously: control returns to the requestor as soon as the file or message has been stored in the Expedite/CICS send data (EXPSDAT) file. (C, used in previous releases, is still supported.) |
| S | Synchronously: control is not returned to the requestor until the file or message has been sent to Information Exchange. (M, used in previous releases, is still supported.) |

If this field is left blank, the value will be taken from your user profile. If specified, the value will, for the duration of your session, override the value specified in your user profile. For more information, see “Process send data” on page 26.

SSMXMSG

This field contains the maximum message size that your system can receive. It is the maximum physical block size your system may receive, excluding transmission control characters and SNA headers, but including Information Exchange message headers. The value is taken from the value in the **Data transmission size** field on the System Options panel; it cannot be overridden.

SSMXMSGP

Leave this field blank. Either it is not required by Expedite/CICS, or the value is supplied by Expedite/CICS and your application cannot override it.

SSPCMD

Leave this field blank. Either it is not required by Expedite/CICS, or the value is supplied by Expedite/CICS and your application cannot override it.

SSREST

Leave this field blank. Either it is not required by Expedite/CICS, or the value is supplied by Expedite/CICS and your application cannot override it.

SSSCHKP

Leave this field blank. Either it is not required by Expedite/CICS, or the value is supplied by Expedite/CICS and your application cannot override it.

SSRCHKP

Leave this field blank. Either it is not required by Expedite/CICS, or the value is supplied by Expedite/CICS and your application cannot override it.

SSTZONE

Specify the time zone of your location in the format Ehhmm, where hh indicates the number of hours and mm indicates the number of minutes east of the Greenwich meridian, or as Whhmm, indicating the hours and minutes west of Greenwich.

Alternatively, you may use one of the following time zone abbreviations. The format is leftjustified and padded on the right with blanks. All full-hour offsets are valid, even if they are not shown below. 1

Table 74. Time zone codes

Time Zone	Description	Time Zone	Description
E1000	Eastern Australia	W0400	U.S. Atlantic Standard
E0900	Japan Standard	W0400	U.S. Eastern Daylight
E0200	Western Europe Daylight	W0500	U.S. Eastern Standard
E0200	Eastern Mediterranean	W0500	U.S. Central Daylight
E0100	British Summer	W0600	U.S. Central Standard
E0100	Western Europe Standard	W0600	U.S. Mountain Daylight

Table 74. Time zone codes

Time Zone	Description	Time Zone	Description
E0000	Greenwich mean time	W0700	U.S. Mountain Standard
		W0700	U.S. Pacific Daylight
		W0800	U.S. Pacific Standard
		W0800	U.S. Alaska Daylight
		W0900	U.S. Alaska Standard
		W1000	U.S. Hawaii Standard

SSEXP

Leave this field blank. Either it is not required by Expedite/CICS, or the value is supplied by Expedite/CICS and your application cannot override it.

Session Start response

When your application sends a Session Start command to the command processor, the command processor forwards the command to Information Exchange. Because Session Start is a response-oriented command, the Expedite/CICS command processor returns the following response as an overlay of the EXPCRSP COMMAREA. When Information Exchange returns a Session Start response, the command processor checks the response to determine whether the session started successfully. You are responsible for making sure that your application checks the Session Start response from the command processor.

The response COMMAREA format that the command processor returns for the Session Start command is:

An additional copybook is EXPCSSR for the RSPDATA field.1

Table 75. Session Start response

Column	Size	Name	Description
1	5	SSRSPCODE	Response number
6	2	SSRSPSVD	Response severity
8	8	SSRCMD	Session start response command name
16	8	SSRACCT	Account ID
24	8	SSRUSER	User ID
32	8	SSRSKEY	Session access key
40	5	SSRRSP	Session start response code
45	5	SSRLSCKP	Last send checkpoint
50	5	SSRLRCKP	Last receive checkpoint
55	1	SSREXP	Expansion indicator

The descriptions of the fields returned to you in the response are:

SSRSPCODE

This field contains a message number that indicates the status of the Session Start command.

This code: Means:

- HI001** HI001 The command processor edits were successful and the command was forwarded to Information Exchange. The command processor places the response from Information Exchange in the response text data field (RSPDATA).
- Your application should check the start session response code field (SSRRSP) to determine if a session started. A value of less than 64 means a session has started.
- The response can indicate either that a session has been successfully started or an error has taken place, indicated by SDIERR.
- HI4xx** Your application can display the message on panels for the user to follow up on, or you can design your application to check for a message and then determine the action that the user should take. See *Expedite/CICS Messages*, for a list of error messages from Expedite/CICS and for recommended corrective actions.

SSRSPSVD

This field contains a code that indicates the severity of the message returned in the SSRSPSVD field. See *Expedite/CICS Messages* for a listing of severity codes.

SSRCMD

This field contains SDISSTAR, which indicates the response is from the Start Session command.

SSRACCT

This field displays your account ID.

SSRUSER

This field displays your user ID.

SSRSKEY

This is the session access key used for all input to Information Exchange during the current session. Expedite/CICS supplies this value to Information Exchange for all commands.

SSRRSP

This field contains the Session Start response code. The field names referred to in the list of session start response codes refer to the field names listed in the *Information Exchange Interface Programming Guide*, not to the field names listed within this manual. The response codes are described below.

This value: Indicates:

- 00000** Normal condition; no error exists. Information Exchange started the session exactly as you requested.
- 00001** In a session using checkpoint-level recovery, the checkpoint numbers for the send and receive side of the session do not match Information Exchange's values. **LSTSNDCP** and **LSTRCVCP** indicate the numbers at which Information Exchange is restarting.
- 00002** The system is restarting the session. There was a prior session, and it is being restarted.
- 00004** The time zone field is invalid. Information Exchange assumes the value of the time zone, and stores a message you can retrieve, specifying the assumed time zone.
- 00008** The value of **MAXMSGCP** is invalid. The valid range of values for this field depends on the particular installation definition.
- 00016** The value of **MAXMSGSZ** is invalid. The valid range of values for this field depends on the particular definition.
- 00032** The value of **TESTREST** is invalid. Information Exchange ignores your request to reset the session and the queued messages.
- 00064** If you are an ESO user, you specified a new password (**NEWPSWRD** field on the Session Start command record) that did not meet the following rules. The password:
- Must not contain the user ID as any part
 - Must be at least six characters in length
 - Must contain at least three different characters
 - Must contain a non-numeric first and last character
 - Must contain at least one non-alphabetic character
 - Must contain at least one alphabetic character
 - Must contain only the valid characters A-Z, 0-9, and special characters #, @, and \$
 - Must be different from the current and five previous passwords
 - Must not contain more than two identical consecutive characters
 - Must not contain more than three identical, consecutive characters from the previous passwords
- Change the new password to conform to these rules
- 00128** The value of **RCVCKPTN** is invalid. The session does not start. **RCVCKPTN** must be blanks (if not restarting receive from a checkpoint) or numeric.
- 00256** The value of **SNDCKPTN** is invalid. The session does not start. **SNDCKPTN** must be blanks (if not restarting send from a checkpoint) or numeric.
- 00512** The restart recovery level differs from the original recovery level. The session does not start. The recovery level must be the same in any session restart as in the original session start.

This value: Indicates:

- 01024** The value of **RRLTYPE** is not valid. The session does not start. **RRLTYPE** must be **C, M, S, or X**.
- 02048** The password is incorrect. The session does not start. The password for this Information Exchange address is not the same as specified in your Session Start command
- 04096** The user ID is invalid. The session does not start. The address is not known to Information Exchange.
- 08192** If you are an ESO user, you have sent three successive Session Starts using an incorrect password. Your Information Exchange user ID has been revoked. Contact your service administrator to request that your password be reset using Information Exchange Administration Services. Resetting the password resumes the user ID.
- 16384** If you are an ESO user, you did not specify a new password on the Session Start command. If the Information Exchange password for an ESO user is the same as that user's normal user ID, a new password must be specified. Modify **NEWPSWRD** in the Session Start command to contain a password that conforms to the rules described for the Session Start response code value of 64.

SSRLSCKP

This field contains the last completed checkpoint number Information Exchange assigned while you were sending messages to Information Exchange. The format is numeric, rightjustified, and padded on the left with zeros.

For group level recovery, this field contains the last checkpoint number assigned by Information Exchange in a Commit response. If no commit point for input operations has been reached, the value is zero. If the value does not match what your system expected, Expedite/CICS will perform a session restart or reset, and recover the message (as sent in the **SSSCHKP** field of the Session Start command). Expedite/CICS should retransmit messages sent to Information Exchange since the indicated checkpoint number in this message.

SSRLRCKP

This field contains the last completed checkpoint number your system sent to Information Exchange for the indicated user ID in a Commit response while receiving messages. The format is numeric, right-justified, and padded on the left with zeros.

For group-level recovery, this field contains the last checkpoint number assigned by your system for committed messages sent from Information Exchange. If no commit point for output operations has been reached, this is zero. If the value does not match what your system expected, Expedite/CICS will perform a session restart or reset, and recover the message.



NOTE: If a session using checkpoint-level recovery is restarted and messages are being sent to your system, they are resent following the Session Start response.

SSREXP

This field contains the value 1.

Set Administrative Response File command

When Information Exchange system messages are received, they are returned to the administrative response file (see “Receiving messages and files” on page 98). The administrative response destination default is set in your user profile and can be changed for the duration of your session, using the Set Administrative Response File command. To define an administrative response file for your application, you pass the Set Administrative Response command to the command processor. If you do not define an administrative response file for your application, the value in your user profile is used. The default is a temporary storage queue named EXPDRE1.



NOTE: This command is an Expedite/CICS command only; it does not have an associated Information Exchange command.

The copybook for this command is EXPADMN.

To issue a Set Administrative Response File command, pass the following COMMAREA format and values to the command processor. 1

Table 76. Set Administrative Response File command

Column	Size	Name	Explanation	Value
1	1	RSPASS	Pass-through indicator	0
2	2	RS-FNAM	Response file name	File name
10	2	RS-FTYPE	Response file type	TS/TD/VB/PG
12	1	RS-FILR1	Filler 1	blank
13	8	RS-FILR2	Filler 2	blank
21	8	RS-CMND	Command name	EXPADMN
29	8	RS-ACCT	Account ID	Account name
37	8	RS-USER	User ID	User ID name
45	8	RS-KEY	Session access key	blank

This value: Means:

>**blank**< Expedite/CICS supplies the field value. You can use the default value in your application, or your application can override it.

blank The field is either not required by Expedite/CICS, or the value is supplied by Expedite/CICS and your application cannot override it.

The descriptions of the fields you place in the COMMAREA are:

RS-PASS

This field indicates whether the command being submitted is defined to the command processor as a pass-through command or one supported by the command processor. For this command, the value must be zero.

RS-FNAM

This field identifies the name of the file where the data is to be placed when received or the name of your application program to be invoked when data is received.

RS-FTYPE

This field further identifies the file in which the data is placed or the application program to be invoked when received:

This value:	Means:
TS	Temporary storage
TD	Transient data
VS	VSAM ESDS
PG	Program name

Leave this field blank. Either it is not required by Expedite/CICS, or the value is supplied by Expedite/CICS and your application cannot override it.

RS-FILR2

Leave this field blank. Either it is not required by Expedite/CICS, or the value is supplied by Expedite/CICS and your application cannot override it.

RS-FTYPE

This field further identifies the file in which the data is placed or the application program to be invoked when received:

RS-FILR1

Leave this field blank. Either it is not required by Expedite/CICS, or the value is supplied by Expedite/CICS and your application cannot override it.

RS-FILR2

Leave this field blank. Either it is not required by Expedite/CICS, or the value is supplied by Expedite/CICS and your application cannot override it.

RS-CMND

This field contains EXPADMN, which identifies this as the Set Administrative Response File command. The format is alphanumeric, left-justified, and padded on the right with blanks.

RS-ACCT

This field is used with the **RS-USER** field to identify the user. The format is alphanumeric, left-justified, and padded on the right with blanks.

RS-USER

This field is used with the **RS-ACCT** field to identify the user. The format is alphanumeric, left-justified, and padded on the right with blanks.

RS-KEY

Leave this field blank. Either it is not required by Expedite/CICS, or the value is supplied by Expedite/CICS and your application cannot override it.

Set Administrative Response File response

Expedite/CICS returns the standard Expedite/CICS response to the user program, using the EXPCRSP format. For information about the response COMMAREA format, see “Command processor responses” on page 63.

This value:	Indicates:
HI000	The command completed successfully.
HIxxx	The data sent to the command processor contained an error. For a list of error messages and recommended actions, see <i>Expedite/CICS Messages</i> .

Diagnosing and solving problems

Expedite/CICS provides several functions for capturing and tracing data flows in the event of a severe error. If you are unable to solve the problem, contact your local support group.

When reporting a problem, you will need to provide at least the following information:

- Information Exchange Account/Userid
- CICS APPLID
- System type
- Expedite/CICS Version

To determine your CICS APPLID: From native CICS, issue CEMT. Expedite/CICS will display your APPLID in the lower right corner of the screen.

When a problem occurs, record all system error messages. Then refer to the messages list in *Expedite/CICS Messages* for explanations and recommended actions. The major topics discussed in this section are listed below:

- [Solving Information Exchange session start problems](#) 305
- [Solving session access key problems](#) 307
- [Restarting a session](#) 308
- [Solving LU 6.2 connection problems](#) 311
- [Solving LU 6.2 session check problems](#) 312
- [Solving common problems](#) 313
- [Checking data sets and programs](#) 326
- [Recovering undeliverable messages](#) 328
- [Using Expedite/CICS problem determination facilities](#) 331

Solving Information Exchange session start problems

Establishing an Information Exchange session requires that you correctly define your CICS environment to Information Exchange and that your application successfully issues a Session Start command.

You must correctly define your CICS environment before you issue a Session Start command, which is defined by a terminal control table entry. The application-to-application definition must be appropriate for the LU 6.2 interface before you try to run your application (see “Solving LU 6.2 connection problems” on page 293).

If your system is correctly defined, it will indicate that it has acquired the connection to Information Exchange. If your system indicates the Information Exchange connection is released, you need to try to connect as described in “Solving LU 6.2 connection problems” on page 293. You might be unable to acquire Information Exchange if:

- Your terminal control table (TCT) definition for Information Exchange on your system or for your system within Information Exchange is incorrect.
- Your VTAM APPL statement is coded incorrectly.
- Your VTAM mode table does not contain entries required by Expedite/CICS. See the *Expedite/CICS Program Directory* for details.
- Information Exchange is currently unavailable.



NOTE: For more information about TCT definitions and VTAM APPL statements, refer to the *Expedite/CICS Program Directory*.

If you are communicating via TCP/IP, the necessary TCP/IP override parameters must be present in the override parameter file (EXPDPRM) that is processed by Expedite/CICS upon startup.

Information Exchange acquisition problems often require CICS systems programmer intervention, but you can do the following checks yourself:

- Use the CICS Executive Diagnostic Facility (CEDF) to determine if the problem is with your application or with your TCT or APPL definitions. Be aware that Expedite/CICS QIDERR, ITEMERR, and NOTFND messages are normal.
- Check your CICS system log for error messages.
- Check Expedite/CICS internal trace TSQs for error messages (see “Internal trace queues” on page 313).
- Check the EXPT TD queue for possible TCP/IP errors.

Solving session access key problems

If Information Exchange receives an incorrect session access key from Expedite/CICS, possible causes include:

- Having a session with the same user ID on a different interface.
- Having a session with the same user ID on another Expedite/CICS system running on another CICS region.



NOTE: It is possible for a user to not be physically logged on but have an active session on another system that is being automatically restarted. If the same user ID starts a session from two systems, the second session overrides the first and Information Exchange communicates with the later session. This causes a checkpoint failure because the counters between Expedite/CICS and Information Exchange are not the same. In addition, a session access key error may occur and messages may be delivered to a system other than the one intended. For these reasons, you should use the same user ID only once on a given system.

To recover from this event, proceed as follows:

1. Log off or end a session on one of the systems.
2. Perform a session start on the session that is still active.
3. If the problem persists, proceed to “Restarting a session” below.

Restarting a session

If requested functions do not seem to be working properly in a session or the session is having problems communicating with Information Exchange, proceed as follows:

1. On the User Administration Selection Menu, select the **List user session status** option and reset the user session. This procedure is described in “Reset a user session” below.
2. To restart a session, follow the procedure provided in the *Expedite/CICS Display Application User’s Guide*.
3. If steps 1 and 2 do not work, proceed as follows:
 - a. Do the following:
 - 1) Ask an Information Exchange service administrator to reset the user session through Information Exchange.
 - 2) Reset the user session through Expedite/CICS as described in “Reset a user session” on page 290.
 - b. Restart the session in Expedite/CICS.
4. If the problem persists, do the following:
 - a. Make note of the user profile settings.
 - b. Delete the user profile as described in the *Expedite/CICS Display Application User’s Guide*.
 **NOTE:** This action will delete all records and data in the files associated with the Account/Userid.
 - c. Recreate the user profile as described in the *Expedite/CICS Display Application User’s Guide*.
 - d. Reissue send and receive requests as needed.

Reset a user session

You might need to reset a session if a system failure occurs and the session is not recoverable. When a session is reset, the steps described below are performed.

- A check is made for active send requests. If any are found:
 1. A session inquiry is performed.
 2. If the session inquiry idle time (the time since the last message transfer) exceeds one minute, a send purge command is issued to Information Exchange, and a fresh send control record is reset so the send request can be restarted.
 3. A cleanup module is linked to perform a reset backout. Because receive requests are backed out to the last commit, any in-process receives are automatically restarted.
- Your active user session profile is purged so that the next time you log on, a new session start is issued.

To reset a user session, proceed as described below.

1. Under **Cmd**, in the field next to each session you want to reset, type S
2. To cancel and return to the Expedite/CICS User Administration Selection menu, press PF12.
3. To process the status command(s), press Enter. Expedite/CICS displays the Reset Session panel of the user whose session is to be reset with the account ID and user ID already filled in.

```

EXPRES           Information Exchange - Reset Session

                Enter or verify ACCOUNT/USERID to be reset

                Account < ACCT1 >
                Userid  < USER01 >

Press ENTER to CONFIRM reset request
Press PF12 to CANCEL  reset request

Command ===>
PF1=Help PF12=Cancel

```

4. To cancel the reset request and return to the List of Users' Status panel, press PF12.
5. To confirm the reset request, press Enter. Expedite/CICS does one of the following:
 - If you are a general user or a service administrator resetting your own session, you are returned to native CICS. A message is displayed indicating the result of the reset. The next time you log on, the Display Application will issue a session start.
 - If you are a service administrator resetting another user's session, you are returned to the List of Users' Status panel. A new session start or a session restart for the user should then be issued.

If you are a service administrator resetting multiple user sessions, you will be asked to confirm each request in turn. As you complete each confirmation, you return to the Reset Session panel. When you complete the last reset request, you are returned to the List of Users' Status panel.

Resetting a user session with IDLT

To reset a user session with transaction IDLT, begin in native CICS.

1. Clear the display and type `IDLTAACAAAAA UUUUUUUU` where:

`AAAAAAA` is the Information Exchange account ID

`UUUUUUUU` is the Information Exchange user ID

The Reset Session panel is displayed with the account ID and user ID fields already filled in.

2. To cancel the reset request and return to native CICS, press PF12.
3. To confirm the reset request and return to native CICS, press Enter.



NOTE: If you do not type the account ID and user ID with the IDLT command, the Reset Session panel is displayed with the account ID and user ID not filled in. While the IDLT resets the user session on the Expedite/CICS side, it is also recommended that you reset the user's session in Information Exchange.

Solving LU 6.2 connection problems

Expedite/CICS automatically tries to acquire an LU 6.2 connection until successful but, on occasion, you may want to test the connection manually. To check the connection between Expedite/CICS and Information Exchange, proceed as described below.

1. Access native CICS on an interactive terminal.
2. Next to the system prompt, type CEMT I CONN(INIE)
3. Press Enter. The following response appears:

```
I CONN(INIE)
STATUS:  RESULTS  - OVERTYPE TO MODIFY
Conn(INIE) Net(IBMORELY)   Ins Acq
```



NOTE: IBMORELY is the NETNAME in the United States

If your display looks like the example above, the connection is acquired. If your display looks like the example above but, Acq is Rel, continue as described below.

- a. Type over Rel with **Acq**.
- b. Press Enter. CICS attempts to reacquire the connection.
- c. Press PF3.

You can also take a connection out of service and then put it back in service to clean up some of the CICS control blocks. Do this by typing over Ins with Out. If the connection status does not change, you may need to end the CEMT command to complete the change by pressing PF3.

After you establish a connection, you can issue a Session Start command. If the communication is still not established, view your CICS system log for error messages. For more information, see “Session Start response” on page 279.

Solving LU 6.2 session check problems

If your connection indicates Acq, you can check the number of sessions that are active (Act) between your system and Information Exchange as described below.

1. Next to the system prompt, type CEMT I M CONN(INIE)
2. Press Enter. The following response is displayed:

```
I M CONN(INIE)
STATUS: RESULTS - OVERTYPE TO MODIFY
Mod(SNASVCMG) Con(INIE) Max(002) Ava( 002 ) Act(002)
Mod(IINAPPC ) Con(INIE) Max(002) Ava( 002 ) Act(002)
```

This connection:	Indicates the connection is:
INIE	Coded into Expedite/CICS and cannot be changed.
SNASVCMG	Used by CICS to control LU 6.2 sessions; SNASVCMG is coded into CICS and cannot be changed.
IINAPPC	Used by Expedite/CICS to send and receive Information Exchange commands and data; IINAPPC is coded into Expedite/CICS and cannot be changed.

If your display does not contain both of these entries, check your installation. If your display shows both entries but Act is not displayed, some or all the sessions were not acquired. Check your console log for VTAM errors and the CICS log for error messages; these errors occur at the initial startup time of CICS.

Common causes of problems in this area include:

- MODETAB entries not defined or defined other than as shown in the program directory. This usually shows up as a VTAM return code of 144B (BIND failure).
- Incorrect definitions in the terminal control table; connections must be INIE and logmode must be IINAPPC. All IINAPPCs are applicable to the U.S. only and may vary. See your *Program Directory* for local values.

Solving common problems

The tables under this heading are provided to catalog typical problems you may encounter and to provide general approaches to isolating and solving those problems.

LU 6.2 connection problems

Table 77. LU 6.2 connection not working properly.

Description	Resolution
LU 6.2 connection not working	Check the LU 6.2 INIE connection and sessions (“Solving LU 6.2 session check problems” on page 294).
HI461 error received.	<ol style="list-style-type: none"> 1. Check CICS system log. Default is MSGUSR. 2. Check CICS messages for security violations; correct definitions as needed 3. Check CICS definitions for connection and sessions; ensure connection is defined as INIE. 4. Check VTAM console log for error messages. 5. Check VTAM definitions; ensure the APPL statement has parameter PARSESS=YES. 6. Verify CDRSC and CDRM are active; activate as needed. 7. Verify that the CICS APPLID defined to VTAM matches the network definition. 8. Inquire whether Information Exchange is available; if yes and this is a new connection, ask the Information Exchange service administrator to check the <ul style="list-style-type: none"> • Service manager definitions for your CICS APPLID • LU 6.2 RELAY definitions for your CICS APPLID 9. Ask network support to check the LU 6.2 RELAY for error messages.
HI462 error received.	Failure is on the network; ask network support to investigate errors for the failing account ID and user ID.
Only one SNASVCMG session is active; cannot issue commands; can send but not receive data.	Check VTAM mode table entry and correct as needed.
IINAPPC session active count is only half of the available count; degraded performance; unable to receive data.	Check VTAM mode table entry for IINAPPC and correct as needed.

Table 77. LU 6.2 connection not working properly.

Description	Resolution
Terminal hangs for two minutes when logging on or issuing a command to Information Exchange.	Check for HI461 or HI462 message in EXPL and EXPM destination queues.

TCP/IP connection problems

Table 78. LU 6.2 connection not working properly.

Description	Resolution
TCP/IP connection not working.	Check the EXPT destination queue for specific error messages. Refer to the <i>IP CICS Sockets Guide</i> for an explanation of the reason code.
HI461 error received.	<ol style="list-style-type: none"> 1. Check the EXPT destination queue for failure on any EZASOKET command. Refer to the <i>IP CICS Sockets Guide</i> for an explanation of the reason code. 2. Check the EXPT destination queue for messages from the TCP/IP Relay indicating that the TCP/IP Relay command has failed. 3. Check the CICS system log. Default is MSGUSR. 4. Check CICS messages for security violations; correct the definitions as needed. 5. If the reason code indicates the connection was refused or the destination is not available, inquire whether Information Exchange is available. 6. Ask network support to check the TCP/IP RELAY log for error messages.
HI462 error received.	Failure is on the network; ask network support to investigate errors for the failing account ID and user ID.
Terminal hangs for two minutes when logging on or issuing a command to Information Exchange.	<ol style="list-style-type: none"> 1. Check for HI461 or HI462 message in the EXPL and EXPM destination queues. 2. Check the EXPT destination queue for failure on any EZASOKET command. Refer to the <i>IP CICS Sockets Guide</i> for explanation of the reason codes

Session start problems

Table 79. Examples-Session start failures

Description	Resolution
Session start response code 2048 or HI350.	Incorrect password; correct or reset password using Information Exchange Administration Services.
Session start response code 4096 or HI351.	Invalid account ID and user ID; correct as needed.
HI423 error received.	No user profile exists in Expedite/CICS and the value in Auto create user is N (No) . Define the user to Expedite/CICS or use a valid Account/Userid.
Terminal hangs for two minutes when logging on to the Display Application.	Check LU 6.2 connection for in-service and acquired indications, as described in Table 77 on page 295.
HI462 or HI461 error received on Session start command.	Check LU 6.2 connection for in-service and acquired indications, as described in Table 77 on page 295.
HI900 ASRA in program EXPOISC1, received on Expedite/CICS password panel.	Ensure all programs are defined as COBOL; particularly in EXPOISC1.
HI123 – HI138 error received.	Indicates a problem with the TCP/IP socket calls. Check the EXPT destination queue for the reason code. For a description of the log record layout, see “Exception message layout” on page 328. Refer to the <i>IP CICS Sockets Guide</i> for an explanation of the reason code.
HI139 – HI143 error received.	Indicates a problem communicating with the TCP/IP Relay. Check the EXPT destination queue for the reason code and explanation.



NOTE: For a full list of Information Exchange session start response codes, see “Session Start response” on page 279. The user application must check HI001 to determine whether the session started or not.

Receive data problems

Table 80. Receive data failures

Description	Resolution
Attempting to receive data with the ESD (Receive PTF) option, but the batch job that is supposed to run and pull the PTF from the VSAM file and put it in a sequential data set does not appear to be executing.	<p>Check the following:</p> <ul style="list-style-type: none"> • The IRDR destination queue is defined and was opened and enabled. • The JP records in the EXPDSRC file have the correct STEPLIB datasets listed, and the EXPBPTF1 module was in the load library specified. <p>Check for problems such as a user message class that is not fully qualified</p>
AICA – Runaway task Interval	Commonly happens if the DTIMEOUT for transaction IMR1 is, set fairly low and/or the data is being received into a program and the program is doing extensive processing, or they are enqueueing on tied-up resources.
Cannot issue receive command; HI9XX error received.	Notify network support.
Cannot issue receive command; HI4XX error received.	Ensure the received command is using correct values.
Cannot issue receive command; HI42 1 error received.	No active session with Information Exchange; issue a Session start, then reissue the receive command.
Cannot issue receive command; HI423 error received.	No user profile exists in Expedite/CICS and the value in Auto create user is N (No) . Define the user to Expedite/CICS or use a valid account ID and user ID.
Cannot issue receive command; HI461 or HI462 error received.	<p>If using SNA communication, check LU 6.2 connection for inservice and acquired indications, as described in Table 77 on page 295.</p> <p>If using TCP/IP communication, check the EXPT destination queue for TCP/IP Relay error and explanation.</p>
Data received in user destination in wrong format.	<p>The problem may be caused by one or more of the items below.</p> <ul style="list-style-type: none"> • First data record is unrecognized. Check the Retain header flag; data is most likely an Information Exchange header. • Data record size is incorrect; check the receive command Handle records as and Max record size settings. • Initial records are correct but the nth record size is incorrect. Ensure the receive command Handle records as setting is not, SPLIT when File type is OTHER

Table 80. Receive data failures

Description	Resolution
Data received is skewed or broken.	The most common reason is trying to receive OTHER type data with the SPLIT option. When Expedite/CICS reaches the end of an Information Exchange segment, it splits the data at that point and continues on to the next record. (It is best to use WRAP when receiving OTHER type data).
HI000 message received, but the data was not in the TD Queue specified. HI900 and HI909 messages when receiving larger messages.	You may have to close the TD Queue before looking at it. In one instance, the runaway task interval was set very low (in the CICS region). When Expedite/CICS was receiving large messages, the user's system thought there was a runaway task and purged the task, resulting in HI909 and HI900 messages.
HI900 message in EXPOISC2 or EXPOTCHD when receiving data. The receive indicator in IE goes on, and then user gets an HI900. Also noticed some AKCS abends (deadlock timeouts) - possible enqueueing problem:	Make sure that the Expedite/CICS files are defined as non-recoverable.
HI900 message when receiving to a program.	If error logs indicate an ABM3 abend code, the program requested a basic mapping service (BMS) operation from a terminal that does not have BMS support. A dump should tell which BMS request the user's program is requesting.
HI999 message when trying to receive into a DataInterchange program.	This means that DataInterchange and Expedite/CICS are out of sync, and the cleanup procedures for DataInterchange need to take place: (EDIS, EDIZ, IDLT, and EDIR).

Table 80. Receive data failures

Description	Resolution
<p>Issuing batch receive, and the receive indicator goes on in Information Exchange, and EXPORCV1 and EXPORCV2 are getting invoked, but the internal reader (IRDR) is not getting invoked.</p> <p>No data received in user destination; data did not arrive in user's mailbox.</p>	<p>Check the following:</p> <ol style="list-style-type: none"> 1. For MVS, BATCHRDR DD statement in CICS startup deck should be: //BATCHRDR DD SYSOUT=(A,INTRDR) 2. TDQ for internal reader should be defined: CEMT I QUEUE (IRDR) STATUS: RESULTS - OVERTYPE TO MODDataInterchangeFY Que(IRDR) Ext Ena Ope 3. PROC named on Display Application batch receive panel should reside in a proclib in their linklist. <p>Check the CICS log for errors. In one instance, the log indicated an ASRA for EXPORCV2. This module was LNKEDT with AMODE(24) instead of AMODE(31). After correcting this problem, the batch job was triggered.</p> <p>Check for problems with the batch job. In one instance the following was found:</p> <p>In step 2 (PGM=EXPBRCV1) there was an override problem:</p> <pre>//EXPBRCV1.CARD DD * // SYSIN override error</pre> <p>In an earlier statement that executes the batch receive program, the statement looked like:</p> <pre>EXPBPTF1 EXEC PGM=EXPBRCV1 , REGION=6M</pre> <p>The job had EXPBPTF1 instead of EXPBRCV1. The EXPBRCV1 .CARD cannot refer back to EXPBRCV1, because it did not exist.</p> <p>Check payment levels with trading partner.</p>

Table 80. Receive data failures

Description	Resolution
<p>No data received in user destination; data is in user's mailbox but is not being received.</p>	<ol style="list-style-type: none"> 1. Check CICS logs for: <ul style="list-style-type: none"> • Transaction abends and possible security failure on LU 6.2 session • TCP/IP sockets interface failure. 2. Check the Expedite/CICS receive queues (in-process and complete) for error messages. 3. Check the Expedite/CICS EXPL, EXPM, and EXPT destination queues for error messages. 4. If using TCP/IP communication, check to make sure the listener task is running. If it is not, start it from native CICS by typing in the transaction ID for the listener (LSTN). 5. Verify that a receive is outstanding: <ol style="list-style-type: none"> a. Check receive counts on user status panel. b. Check receive count on session inquiry panel. c. Check Information Exchange Administration Services trace facility for receive command. 6. Check Information Exchange Administration Services mailbox for receive indicator on. 7. If using SNA communication, check the use count in EXPOISC2; it should not be zero. <p>If the use count is zero, check the CICS system log for errors. Information Exchange may be unable to start transaction ISC2 on your CICS region due to an authorization failure. Transaction ISC2 may be deferred on an external security manager.</p> <p>If using TCP/IP communication, check the use count in EXPOTCHD. It should not be zero.</p> <p>If the use count is zero, check the EXPT destination queue for errors. Information Exchange may have encountered an error trying to connect to the Expedite/CICS listener.</p> 8. Check the VTAM log for session failures (for SNA communication) or the EXPT destination queue for TCP/IP errors. 9. Check for Journal buffers larger than the transmission size entered on the Define System Options panel. 10. Check that Account/Userid is not in use by another Information Exchange interface. 11. Check the Information Exchange mailbox for system error messages.

Table 80. Receive data failures

Description	Resolution
Not receiving all data into a VSAM file.	Make sure the file is initialized with a dummy record.
Taking a long time to receive.	Check the RUSIZE . It should be at least 1024 (3840 may be better).
Unable to receive after upgrading from Expedite/CICS V1R3 to V4.	With V4, the maximum transmission size is 26000. With V1R3, the maximum transmission size was 12000. Either change the transmission size on the System Option's panel in Expedite/CICS or change the program to accommodate the larger transmission size.
Unable to receive.	Check the Expedite/CICS trace. If it shows the HI908 message, which means 'no space', a reorg procedure should be set up for the files.
Unable to receive. Receive indicator goes on in IE, EXPOISC2 or EXPOTCHD is getting invoked, and EXPOIMR1 get invoked and IMR1 seems to use a lot of CPU time, but no data is received.	<p>The EXPRDAT file may fill up quickly depending on the size of the file you are receiving.</p> <p>Check to see if there are any additional programs in the PLT besides EXPOSTRT that may be causing problems.</p>
Unable to receive. Receive indicator goes on in IE, EXPOISC2 or EXPOTCHD is getting invoked, but EXPOIMR1 is not getting invoked.	Check to see if there are any additional programs in the PLT besides EXPOSTRT, such as a user exit, that may be causing problems.
Unable to receive. The receive indicator goes on in IE, but no data is received and no checkpointing is done. Can receive some types of data, and can send/receive with other user IDs.	Check CICS log for error messages. If there is an abend in module DFHFCJL (the file control journal module), the BUFSIZE for the DFHJCT system initialization table entry may be too small. This BUFSIZE value must be greater than the largest transmission (block) size that you will receive plus some padding for journal. The default Expedite/CICS transmission size is 26000.

Table 80. Receive data failures

Description	Resolution
Unable to receive, although the Information Exchange receive indicator goes on.	<p>If using SNA communication:</p> <ul style="list-style-type: none"> • Check the use count of EXPOISC2. If it is 0, it is not getting invoked. • Check the ISC2 transaction definition for the TRANSec value. <p>If using TCP/IP communication:</p> <ul style="list-style-type: none"> • Check the count of EXPOTCHD. If it is 0, it is not getting invoked. • Check the TCHD transaction definition for the TRANSec value. <p>In one instance, the value was 09, which prevented the remote system (IE Front End) from starting the transaction.</p>
User stopped all of the continuous receives in Expedite/ CICS, but when the region came up the next day, continuous receives were started. Why?	The user had transaction EDIR from SEQINPUT for CICS, so this is what was triggering the session start up each time CICS was brought up.
When a receive is issued for a mailbox that is empty, and the receive is for a program, Expedite/ CICS returns the TSQ name in the COMMAREA, and the TSQ is empty.	The user's program needs to check byte 39 of the receive long header (MSGGRP IN - Message Grouping Indicator) to see if it is an E for (ENDDATA)

Send data problems

Table 81. Send data failures

Description	Resolution
Batch send problems.	<p>Check the following:</p> <ul style="list-style-type: none"> • EXPDPTF file is allocated and opened. • Batch send monitor interval is set to something other than zero. • If a data exception program check interrupt occurs, ensure the EXPDPTF file has a record containing 37 zeros and a record containing 37 nines.

Table 81. Send data failures

Description	Resolution
Data was sent but did not arrive in the destination mailbox.	<p>Proceed as follows:</p> <ol style="list-style-type: none"> 1. Check the message status in Expedite/CICS send queues for both in-process and complete send requests. 2. Check Expedite/CICS EXPL, EXPM, and EXPT destinations for error messages. 3. Check the audit trail for sent messages on Information Exchange Administration Services. 4. Check the sending mailbox for *SYSTEM* *ERRMSG* messages. 5. Check the user application (log) to verify the message was actually passed to Expedite/CICS and HI000 was returned from Expedite/CICS.
Deadly embrace on send side.	Make sure the Expedite/CICS files are defined as non-recoverable.
HI421 error received.	Session with Information Exchange might be inactive; issue Session start if needed.
HI423 error received.	No user profile exists in Expedite/CICS and the value in Auto create is N (No). Define the user to Expedite/CICS or use a valid Account/ Userid.
HI432 – HI434 error received.	Check Expedite/CICS translate table and Information Exchange alias table entries; correct the table or the user ID, then reissue the send request.
HI444, HI445 or HI48X error received.	<p>Check the EDI header and trailer for errors; the Expedite/ CICS error message will point to the starting or ending records where the error occurred. Ensure the Expedite/CICS translate table entry is valid.</p> <p>Correct the data or the table, then reissue the send request beginning with the interchange in error and including all subsequent inter changes.</p>
HI500, HI504 or HI505 or HI509 error received.	Expedite/CICS and Information Exchange are either out of synchronization or the session access key does not match. Issue a Session start command, then reissue the send request.
HI123-HI138 error received.	Indicates a problem with the TCP/IP socket calls. Check the EXPT destination queue for the reason code. Refer to the IP CICS Sockets Guide for an explanation of the reason code.
HI139-HI143 error received.	Indicates a problem with the TCP/IP relay commands. Check the EXPT destination queue for the reason code. For a description of the log record layout, see “Exception message layout” on page 328.

Table 81. Send data failures

Description	Resolution
HI507 message when trying to send.	<p>Check the following:</p> <ul style="list-style-type: none"> • Make sure the Expedite/CICS files are defined as nonrecoverable. • Make sure that the EXPSDAT file is defined correctly. The EXPSDAT file needs to have a record containing approximately sixty entries of the number 9.
Issuing batch send and getting the 'elapsed time has passed, please check you CICS region' message.	Either the EXPS interval time is set to 0 (as defined on the System Option's panel), or program EXPOSTRT is not in the PLT.
Looping of restart reset and HI467. If users send new data from DI, everything is ok. If they pull a file out of the STORE and resend it (which is a normal process for DI), it hangs with the file in ACTIVE status and the user's session starts looping with restart restart reset.	<p>Make sure that the value in the MSGRCPTS field of the send message is valid.</p> <p>In DataInterchange, there are several profiles. When sending the original files, the field may be filled in correctly. However, when using the STORE procedure, if the field is blank, the requestor profile is used and in that profile may insert an invalid value, such as inserting a Y where an F is expected.</p>
Send is stuck in ACTIVE status. IDLT did not work and normal PD has been checked.	Disable IST1 transaction and do an IDLT. This should cause the ACTIVE send to be changed to a NORMAL status. Purge the failing NORMAL send and reenable transaction IST1. Restart the session and the sends should flow fine.
Sending is very slow when sending many small files from several user IDs.	EXPDSRC may be defined with the CI size too large. If several Information Exchange users are active simultaneously, each sending/receiving user performs a CI lock. If the CI size is very large, a significant portion of the data is locked, thus causing the other sending/receiving transactions to wait. Reducing the CI size of EXPDSRC to the record size may improve throughput.
Unable to send. Files are staying in the NORMAL status and not going to the ACTIVE status.	<p>If a user is running asynchronously, program EXPOIST1 should start via transaction IST 1. If this program is enabled but is not starting, change the user profile to run synchronously, which means that EXPOIST1 will be linked too.</p> <p>Also make sure there are no security violations related to IST1</p>

Compression problems

Table 82. Compression problems

Description	Resolution
Abend APDA received.	Check the CICS definition for the Comm-Press programs. They should be defined as assembler programs in the PPT.
HI968 message received	Check that the LKUPTBLC program is properly defined in the PPT and that the load library where the module resides is in your CICS start up JCL.
HI969 message.	Check that the COMPCICS program is properly defined in the PPT and that the load library where the module resides is in your CICS start up JCL.
'Unable to load decompression program' message in the log.	Check that the DCMPCICS program is properly defined in the PPT and that the load library where the module resides is in your CICS startup JCL.
HI436, HI439 and HI449 messages.	These messages result from unexpected return codes from one of the Comm-Press modules. The return code is written to the log. Refer to the documentation provided by Comm-Press Inc. for a description of their return codes.

Miscellaneous problems

Table 83. Miscellaneous problems

Description	Resolution
Abend APCY.	Abend APCY may occur if COBOL2=YES is not specified in the SIT.
Continuous HI467 messages and restarts (appears to be looping).	Check the EXPR (Activity monitor interval). If it is too low, it could cause a problem:
Getting HI926 ERROR READING EXCEPTION DESTINATION TDQUEUE NAME or HI900 SEVERE ABEND IN PROGRAM EXPOSTRT upon startup, or HI901 trying to logon to LGO1.	Make sure the EXPDSRC and EXPDERR files are opened and enabled.

Table 83. Miscellaneous problems

Description	Resolution
To send the Expedite/ CICS trace to GXS	Use the send file option and make sure it is sent as LL-type data. The trace name is EXPDTRCA or EXPDTRCB.
TSQs filling up.	TSQs should not be defined as recoverable. If they are, they could fill up and cause problems - they will not be deleted on warm start.

Checking data sets and programs

The CICS commands and accompanying illustrations provided under this heading will help you determine if your system is meeting minimum requirements for VSAM and destination data sets and for program definitions.

Determining the status of VSAM data sets

To determine if you have the required VSAM data sets defined and opened, from native CICS issue: **CEMT IQ(*)**

The Expedite/CICS display should be similar to the illustration below. Of the destinations shown, EXPDTST is optional; the others are required and must be open. If any are missing or closed, correct the error and retry the command.I

```

I FILE(EXP*)
STATUS: RESULTS - OVERTYPE TO MODIFY
Fil(EXPDERR) Vsa Ope Ena Rea Upd Add Bro Del      Sha
Dsn( DSPEDI45.CICS410.EXPDERR                    ) Max( 00000000 )
Fil(EXPDKEY) Vsa Ope Ena Rea Upd Add Bro Del      Sha
Dsn( DSPEDI45.CICS410.EXPDKEY                    ) Max( 00000000 )
Fil(EXPDPTF) Vsa Ope Ena Rea                      Bro  Sha
Dsn( DSPEDI45.CICS410.EXPDPTF                    ) Max( 00000000 )
Fil(EXPDSRC) Vsa Ope Ena Rea Upd Add Bro Del      Sha
Dsn( DSPEDI45.CICS410.EXPDSRC                    ) Max( 00000000 )
Fil(EXPDTST) Vsa Ope Ena Rea                      Bro  Sha
Dsn( DSPEDI45.CICS410.EXPDTST                    ) Max( 00000000 )
Fil(EXPHPHP) Vsa Ope Ena Rea Upd Add Bro Del      Sha
Dsn( DSPEDI45.CICS410.EXPHPHP                    ) Max( 00000000 )
Fil(EXPRDAT) Vsa Ope Ena Rea Upd Add Bro Del      Sha
Dsn( DSPEDI45.CICS410.EXPRDAT                    ) Max( 00000000 )
Fil(EXPSDAT) Vsa Ope Ena Rea Upd Add Bro Del      Sha
Dsn( DSPEDI45.CICS410.EXPSDAT                    ) Max( 00000000 )

SYSID=CICS APPLID=SITTEST
RESPONSE: NORMAL                                TIME: 11.06.41 DATE: 06.13.00
PF 1 HELP          3 END                        7 SBH 8 SFH 9 MSG 10 SB 11 SF

```

Determining the status of destination data sets

To determine if you have the required destination data sets defined and opened, from native CICS issue: **CEMT**

The Expedite/CICS display should be similar to the illustration below. Of the data sets shown, you should see at least EXPL and you should also see one or more IRDR queues.

```

I Q(*)
STATUS: RESULTS - OVERTYPE TO MODIFY
Tdq (EXPL)          Ext          Ena Ope
Tdq (EXPM)          Ext          Ena Ope
Tdq (IRDR)          Ext          Ena Ope
:
:
RESPONSE: NORMAL          TIME: 15.32.57 DATE: 04.29.94
PF
1 HELP          3 END

```

Determining the status of Expedite/CICS program definitions

The Expedite/CICS program names are prefixed with EXPO. To determine if you have required EXPO**** programs defined as COBOL, from native CICS issue: **CEMT I PROG(EXPO*)** The Expedite/CICS display should be similar to the illustration below, except that it will contain many more entries. A full listing of the programs is provided in the *Expedite/CICS Program Directory*.

```

I PROG(EXPO*)
STATUS: RESULTS - OVERTYPE TO MODIFY
Prog(EXPOADM1) Len(00000000) Cob Pro Ena Pri    Ced
Prog(EXPOADM2) Len(00000000) Cob Pro Ena Pri    Ced
Prog(EXPOADM3) Len(00000000) Cob Pro Ena Pri    Ced
:
:
RESPONSE: NORMAL          TIME: 15.32.57 DATE: 04.29.94
PF
1 HELP          3 END

```

Recovering undeliverable messages

If an error occurs when Expedite/CICS attempts to deliver a message to a specified destination, Expedite/CICS marks the message in error. When the error is corrected, you can release the data using the Display View option. After you recover undeliverable messages, be sure to delete the associated RC and RD records. The procedures in “Recovering undeliverable messages with an online application” on page 311 and “Recovering undeliverable messages with a batch procedure” on page 312 discuss recovery techniques. For detailed information, see “Receive error processing” on page 106.

Recovering undeliverable messages with an online application

If an error occurs during receive processing, you can use the sample algorithm below as a last alternative to retrieve queued VSAM records as complete messages. The objectives of the algorithm are to read RCn records sequentially and to use the pointers obtained from RCn to build a key range to retrieve RD records that belong to the same file or message. The record layout is provided in copybook, EXPCRCV.

1. To establish the RC key value, proceed as follows:
 - a. Move **RC** to **RC-TYPE**.
 - b. Move low-values (hex ‘00’) to the rest of the key fields. To retrieve messages for a particular Account/Userid, move the account name to **RC-ACCT** and the userid name to **RC-USERID**.



NOTE: If you know the control ID number of the receive request in error, move that ID to **RC-UNIQUEID-KEY**.

2. Read the next RC record.
3. If **RCN-TYPE = RC**, exit.
4. If **RCN-SEQUENCE = 0**, add **1** to **RCN-SEQUENCE** and go to Step 2.
5. Set up the RD key value (32 bytes) as follows:
 - Move the **RCN-RD** pointer to a 26-byte alphanumeric field.
 - Move the **RCN-RC V-STARTING-SEQ** to a 6-byte alphanumeric field (**RDSEQUENCE**).
6. If **RD-SEQUENCE** is greater than **RCN-RCV-ENDING-SEQ**, increment **RCN-SEQUENCE**, then go to Step 2.



NOTE: At this point, you will have one complete message file, which includes the 30-byte RD key, the Information Exchange headers, and the data.

7. Using the RD key value established in Step 5, read the EXPRDAT data set.
8. Save the RD record.
9. Increment **RD-SEQUENCE**, then go to Step 6.
10. End.

Cleanup after recovering undeliverable messages



NOTE: To enable reuse of VSAM workspace, you must delete:

- All manually retrieved messages (RRD records) from the EXPRDAT file.
- The RCN record associated with the RDS (in the EXPDSRC file).

The following COBOL CICS statement will delete all RC and RD records.

```
WORKING-STORAGE SECTION.
*
*
*
01 KEYVAL      PIC X VALUE 'R'.
*
*
*
PROCEDURE DIVISION.
*
*
*
EXEC CICS DELETE DATASET('EXPRDAT')
      RIDPLD(KEYVAL)
      KEYLENGTH(1)
      GENERIC
      END-EXEC.
```

To delete all RC records, change EXPRDAT to EXPDSRC.

Recovering undeliverable messages with a batch procedure

If an error occurs during receive processing, the sample batch procedure described below can be used as a last alternative to retrieve queued VSAM records as complete messages:

1. Use the IDCAMS PRINT function to list all RCN records.
2. Examine each RCN to decide which message should be recovered.
3. Use the IDCAMS REPRO function to retrieve all RD records belonging to the message. Set the key range for REPRO (record layout is provided in copybook EXPCRCV) as described below.

FROMKEY:

Position:

Contains:

1-26

RCN-RD-POINTER obtained from RCN record (position 844 - 868).

27-32

RC-RC V-STARTING-SEQ obtained from RCN record (position 308 - 313).

TOKEY:

Position:

Contains:

1-26

Same as **FROMKEY**.

27-32

RC-RCV-ENDING-SEQUENCE obtained from RCNN record (position 314 - 319).

4. Delete the RD records from the EXPRDAT file, and the RCN record associated with the RDS from the EXPSRC file.

Using Expedite/CICS problem determination facilities

The Expedite/CICS trace facility provides the following trace destinations for problem determination:

- Internal trace temporary storage queues (TSQ), EXPDTRCA/B, (page 313)
- Log destination transient data queue (TDQ), EXPL, (page 329)
- Exception reporting transient data queue (TDQ), EXPM, (page 329)
- TCP/IP error transient data queue (TDQ), EXPT (page 330)

Various information can be written to each trace destination; however, exception messages are always written to the trace destinations in use. This chapter provides reference information about how the trace destinations are defined and used; for information about how to turn the trace on and off, see “Customizing trace options” on page 43. Example trace messages are provided in “Sample trace messages” on page 317.

When developing and testing Expedite/CICS applications, the trace function is useful for tracing Expedite/CICS commands and responses to and from:

- User written applications
- The Display Application
- The Expedite/CICS command processor
- Information Exchange.

Overall message flow between each of the systems is traced and severe errors are identified.



NOTE: You might also find it helpful to use Information Exchange problem determination aids such as viewing mailboxes, audit information, and session trace information. For help in this regard, refer to the *Information Exchange Administration Services User's Guide*.

Internal trace queues

Two internal trace TSQs, EXPDTRCA and EXPDTRCB, are used for problem determination and resolution. These TSQs can contain the following information:

- Expedite/CICS commands sent to the command processor and returned responses
- Expedite/CICS commands sent to Information Exchange and returned responses
- Data sent to and received from Information Exchange
- Error messages (severity 08 and above)
- Informational messages.

Regarding the internal trace TSQ:

- The information written is determined by flag settings on the Trace Options panel, as described in “Customizing trace options” on page 43.
- No definition is required; it is dynamically created as needed. Data is written into EXPDTRCA up to the number of records specified in the Switch trace table at record field of the Trace Options panel, then Expedite/CICS switches to EXPDTRCB, first deleting any data already in EXPDTRCB. This procedure then repeats for EXPDTRCB, switching back to EXPDTRCA when the number of records specified in the Switch trace table at record field is reached.
- It can be viewed from native CICS by issuing: CEBR EXPDTRCA or CEBR EXPDTRCB.

- The trace switches to conserve temporary storage, unless the value in the Switch trace table at record field on the Trace Options panel is set to zero.
- Example trace messages are provided in “Sample trace messages” on page 317.

Trace elements

The topics under this header describe elements that can be written to the trace.

Expedite/CICS and Information Exchange commands and responses

These include commands you send to the Expedite/CICS command processor when requesting a given function, the command processor responses, and all commands and data sent to and received from Information Exchange. It is the writing of these commands that you can control from the Trace Options panel, as explained in “Customizing trace options” on page 43.

Command and response formats are provided for:

- Expedite/CICS in *Customizing and Developing Applications with Expedite/CICS*.
- Information Exchange in the *Information Exchange Interface Programming Guide*.

Informational messages

The informational messages produced by Expedite/CICS are listed below.

INITIAL EXPEDITE/CICS STARTUP

Explanation: Written when Expedite/CICS is first started or after links to Information Exchange have been lost and Expedite/CICS needs to reacquire the connections and restart or reset user sessions, if necessary.

***** acct userid AUTOMATICALLY STARTED *****

Explanation: The activity monitor automatically started the Information Exchange session of the specified Account/Userid. This will occur for users with user profiles that have the value in the Auto logon field set to Y (Yes), or for users who previously had an active session with Information Exchange.

CLEANUP KICKED OFF FOR ===> acct userid

Explanation: The activity monitor found it necessary to clean up this user ID and restart the user’s Information Exchange session.

THIS RECORD BEING BACKED OUT BY CLEANUP

Explanation: Written when uncommitted receive request data is being backed out of Expedite/ CICS.

CLEANUP IS ALREADY ACTIVE FOR THIS USER

Explanation: The current call to the cleanup module is being terminated because the routine is already active.

SESSION RESTART FOR ===> acct userid

Explanation: Written when Expedite/CICS discovered a restart is necessary while processing a send or receive request.

ACTIVITY MONITOR IS BEING STARTED

Explanation: The activity monitor is starting; it will monitor session activity and perform session restarts as needed.

STOPPAGE OF RECEIVE DETECTED, RESTARTING USER.

Explanation: The activity monitor detected a user receive processing error. Expedite/CICS will try to restart the user and get the receive working again.

RECORD BEING DELETED BY THE ACTIVITY MONITOR

Explanation: The activity monitor is purging control records associated with successfully completed send and receive requests that have met the expiration date. This is controlled by the values set in the Send file retention and Receive retention fields of a user profile. After four months, the activity monitor purges control and data records associated with requests with status: E-HIXXX, COMPLETE, and HELD. To avoid peak processing times, this is not done between the times specified on the Define System Options panel.

ACTIVITY MONITOR TERMINATING, MULTIPLE COPIES ARE EXECUTING

Explanation: Because the activity monitor is running, this iteration of the activity monitor is being terminated.

INITIATING SEND FUNCTION FOR =====> acct userid TO acct1 userid1

Explanation: A send request was issued by acct userid to send to acct1 userid1 and Expedite/ CICS is initiating the send.

NO MORE DATA TO SEND FOR =====> acct userid

Explanation: The send function completed for the specified acct userid or Expedite/CICS determined there was no more data to send.

SEND ALREADY ACTIVE FOR =====> acct userid

Explanation: The send function is currently running; the send request just issued is being queued for sending to Information Exchange.

Error messages

The general format of error messages is:

```
<xxxx><account userid><program><HIyyy>< error text.....>
```

This value:

Indicates the:

xxxx

Transaction ID under which the problem occurred

This value:	Indicates the:
account	Account under which the problem occurred
userid	User ID under which the problem occurred
program	Name of the program in which the problem occurred
HIyyy	Expedite/CICS error message
error text	Text associated with the error

The detailed format of these error messages can be found in *Expedite/CICS Messages*.

Only Expedite/CICS error messages of severity 08 or above are written to the trace destinations. Display Application panel dialogue messages are not written, no matter how severe, because writing of error messages is primarily for notifying users or systems support personnel of exception errors that may require their attention. If a problem occurs while using the Display Application, a user is notified immediately on the panel and the mistake can be immediately corrected.

Although the main destination for writing exception messages is the exception reporting TDQ (EXPM), these error messages are also written to log TDQ (EXPL) and to the internal trace TSQs (EXPDTRCA and EXPDTRCB) if any of the trace options are set to Y.

Another type of error message sent from Information Exchange to Expedite/CICS, SDIERR is traced by either the Command, Send or Receive flag depending on why it was sent from Information Exchange; that is, in response to what command. Expedite/CICS processes the SDIERR and returns an appropriate error message if necessary.



NOTE: The SDIERR format can be found in Table 10 on page 66 or in the *Information Exchange Interface Programming Guide*.

Sample trace messages

This topic provides sample trace information. As a matter of convenience, a Trace Options panel illustration is provided below.

```

EXPMTRI                               Trace Options

Enter Y (yes) or N (no) in the fields

Purge
  Purge trace.. < N >

Trace
  Commands..... < Y >
  Send..... < Y >
  Receive..... < Y >
  Data..... < N >

TCP/IP Trace Options
  Start up Parm..... < N >
  TCP/IP Send..... < N >
  TCP/IP Receive..... < N >

Switch trace table at record.... < 20000 > (00100 - 32760)
                                         (00000 - no switching)

Write Trace to Log EXPLOG1

  Log Trace.... < Y >      (Activate trace for EXPL destination)

HI305 ENTER FIELD INFORMATION AND PRESS PF3(END) TO SAVE CHANGES.

Command ==>
PF1=Help  PF3=End  PF12=Cancel

```

The sample below shows the information that is written to the trace queues (EXPDTRCA/B) and to EXPL if you use TCP /IP communication and have the **TCP/IP Start up Parm**s trace option set to **Y** (Yes).

```

Command or Message
0000003 EXPOPARM 12:50:04 COMMUNICATION PARAMETER IS TCP
0000003 EXPOPARM 12:50:04 MAXSOC 0050 CONVERTED TO BINARY --> ..
0000003 EXPOPARM 12:50:04 LENGTH OF OCTET 1 IS 3, OCTET IS NUMERIC: 164
0000003 EXPOPARM 12:50:04 LENGTH OF OCTET 2 IS 3, OCTET IS NUMERIC: 120
0000003 EXPOPARM 12:50:04 LENGTH OF OCTET 3 IS 3, OCTET IS NUMERIC: 107
0000003 EXPOPARM 12:50:04 LENGTH OF OCTET 4 IS 2, OCTET IS NUMERIC: 35
0000003 EXPOPARM 12:50:04 IP ADDR 164.120.107.35 IS NOW BINARY -->u..
0000003 EXPOPARM 12:50:04 PORT NUMBER 01900 CONVERTED TO BINARY -->,%
0000003 EXPOPARM 12:50:04 ACTIVITY TIMEOUT VALUE IS: 01500
0000003 EXPOPARM 12:50:04 RECEIVE TIMEOUT VALUE IS: 01000
0000003 EXPOPARM 12:50:04 LENGTH OF OCTET 1 IS 3, OCTET IS NUMERIC: 164
0000003 EXPOPARM 12:50:04 LENGTH OF OCTET 2 IS 3, OCTET IS NUMERIC: 120
0000003 EXPOPARM 12:50:04 LENGTH OF OCTET 3 IS 3, OCTET IS NUMERIC: 107
0000003 EXPOPARM 12:50:04 LENGTH OF OCTET 4 IS 2, OCTET IS NUMERIC: 35
0000003 EXPOPARM 12:50:04 IP ADDR 164.120.107.35 IS NOW BINARY -->u..
0000003 EXPOPARM 12:50:04 PORT NUMBER 01521 CONVERTED TO BINARY -->,1
0000003 EXPOPARM 12:50:04 SEND SESSIONS 010 CONVERTED TO BINARY -->..
0000003 EXPOPARM 12:50:04 RECV SESSIONS 004 CONVERTED TO BINARY -->..
0000003 EXPOPARM 12:50:04 Expedite/CICS COMMUNICATING VIA TCP

```

CICS starts the Expedite/CICS startup program during system initialization and displays the following message:

```
*** EXPOSTRT {exps} HAS BEEN STARTED BY PLT ***
```

The startup program calls the activity monitor which starts each user ID that previously had an active session or has **Auto logon** set to **Y** in the user profile. In the sample below, an inquiry is issued for the SYSTEM DEFAULT user ID. The SDIERR messages are returned from Information Exchange because this user ID is a dummy Expedite/CICS ID and is not a valid Information Exchange Account/Userid. This inquiry is used by Expedite/CICS to determine if the links to Information Exchange have been acquired. If there is no response from Information Exchange for the session inquiry, Expedite/CICS tries to establish the links.

```

Command or Message
0000033 02/28/98 09:32:31 Initial startup for Expedite/CICS
0000033 pgmname 09:32:32 0 SDIINQS SYSTEM DEFAULT SDIINQSRL1
0000033 pgmname 09:32:32 SDIINQS SYSTEM DEFAULT DEFAULT SDIINQSRL1
0000033 pgmname 09:32:32 SDIERR THE FOLLOWING COMMAND WAS NOT EXECUTED BECAUSE: 00004SDIINQS
SYSTEM DEFAULT DEFAULT SDIINQSRL1
0000033 pgmname 09:32:32 HI00104SDIERR THE FOLLOWING COMMAND WAS NOT EXECUTED BECAUSE:
00004SDIINQS SYSTEM DEFAULT DEFAULT SDIINQSRL1
    
```

Restarting a user's session with Information Exchange

The following examples show an internal trace for a user just after CICS startup, as Expedite/ CICS restarts the user's session with Information Exchange including functions that were active when the CICS system was shut down.

Commands beginning with a numeric value indicate a command issued to the Expedite/CICS command processor either by a user program or by Expedite/CICS programs, such as the Display Application. In the sample below, the Expedite/CICS Session Inquiry command is issued to the command processor. Data found in this trace can be mapped back to the Session Inquiry command.

```

Command or Message
0000033 02/28/98 09:32:32 *** ACCT USER09 AUTOMATICALLY STARTED **
0000034 pgmname 09:32:32 0 SDIINQS ACCT USER09 SDIINQSRL1
    
```

Commands beginning with SDI* are Information Exchange commands. Expedite/CICS converts Expedite/CICS commands into Information Exchange commands, and then issues them to Information Exchange. In the sample below, a session inquiry command is issued to Information Exchange, and Information Exchange returns the session inquiry response. Data found in this trace can be mapped back to the indicated commands.

```

Command or Message
0000034 pgmname 09:32:32 SDIINQS ACCT USER09 SSTDU2DSDIINQSRL1
0000034 pgmname 09:32:32 SDIINQSRACCT USER09
SSTDU2DL94022809323294022807465001454200000200000000001124 00000200000200
    
```

The sample below shows the response format returned by the Expedite/CICS command processor to the program that issued the Expedite/CICS command SDIINQS.

```

Command or Message
0000034 pgmname 09:32:32 HI00T04SDIINQSRACCT  USER09
SSTEDU2DL94022809323294022807465001454200000200000000001124 0000020

```

Session start and response trace sample

Before the activity monitor starts a new session with Information Exchange, it performs a cleanup to reset the user ID on Expedite/CICS to the last commit. The session start command sent to Information Exchange and the session start responses from Information Exchange are also displayed.

```

Command or Message
0000034 pgmname 09:32:33 CLEANUP KICKED OFF FOR ----> ACCT  USER09  RESET
0000034 pgmname 09:32:33 SDISSTA ACCT  USER09  SDISSTAREXPICST4.50G2600000001SDICMIT
RESETS0000000000W
0000034 pgmname 09:32:33 SDISSTARACCT  USER09  SSTF78M40000000000000003260000402

```

Expedite/CICS then moves on to the session of the next user ID which has an Expedite/CICS profile.

```

Command or Message
0000033 02/28/98 09:32:33 *** ACCT  USER001  AUTOMATICALLY STARTED ***
0000035 pgmname 09:32:33 0          SDIINQS ACCT  USER001  SDIINQSRL1
0000035 pgmname 09:32:33 SDIINQS ACCT  USER001  SSTD7UQISDIINQSRL1
0000035 pgmname 09:32:33 SDIINQSRACCT  USER001
SSTD7UQIL94022809323394022804320900500000000000000004959 0000000000000000
0000035 pgmname 09:32:33 HI00T04SDIINQSRACCT  USER001
SSTD7UQIL94022809323394022804320900500000000000000004959 00000000

```

When a session start is issued, it starts the asynchronous send transaction to see if there is any send data to be sent. The trace indicates that there was no more data to send.

```

Command or Message
0000036 pgmname 09:32:33 NO MORE DATA TO SEND FOR ----> ACCT  USER001

```

Next, a cleanup, a session start, and a start of the asynchronous send transaction are issued for this user ID.

```

Command or Message
0000035 pgmname 09:32:33 CLEANUP KICKED OFF FOR ----> ACCT  USER001  RESET
0000035 pgmname 09:32:33 SDISSTA ACCT  USER001  USER001  SDISSTAREXPICST4.50G2600000001SDICMIT
RESETS0000000000W
0000035 pgmname 09:32:34 SDISSTARACCT  USER001  SSTF78WL00000000000000003260000402
0000037 pgmname 09:32:34 NO MORE DATA TO SEND FOR ----> ACCT  USER001

```

In the sample below, a user ID starts a new session with Information Exchange using Expedite/ CICS with TCP/IP communication (EXPCICST). No session inquiry is performed, as indicated by the omission of a session inquiry. The session start could be generated by logging on to the Expedite/CICS Display Application or by issuing a session start from a user program interface. When SNA communication is used, EXPCICSS is displayed instead of EXPCICST.

```

Command or Message
0000043 pgmname 09:32:44 0          SDISSTA ACCT  USER2  USER2
0000043 pgmname 09:32:44 CLEANUP KICKED OFF FOR ----> ACCT  USER2  RESET
0000043 pgmname 09:32:45 SDISSTA ACCT  USER2  USER2   SDISTAREXPICST4.50G2600 000001SDICMIT
          RESETSES00000000000W
0000043 pgmname 09:32:45 SDISSTARACCT  USER2  SSTF8C3100000000000003260000402
0000043 pgmname 09:32:45 HI00100SDISSTARACCT  USER2  SSTF8C3100000000000003260000402
0000044 pgmname 09:32:45 NO MORE DATA TO SEND FOR ----> ACCT  USER2
    
```

Common Expedite/CICS functions trace sample

The following examples show traces of common functions being performed in Expedite/CICS.

In the sample below, the PROCESSQ command is issued by an Expedite/CICS user through the Expedite/CICS Display Application while viewing in-process or completed messages for send and receive requests.

```

Command or Message
0000119 pgmname 09:49:53 OS@#00017  PROCESSQACCT  USER09  ACCT  USER09  SC
0000119 pgmname 09:49:53 HI000
0000124 pgmname 09:50:08 OS@#00018  PROCESSQACCT  USER09  ACCT  USER09  RC
0000124 pgmname 09:50:08 HI000
    
```

In the sample below, the message queue query command is issued to query the Information Exchange mailbox. The HI675 code indicates that all data was returned.

```

Command or Message
0000371 pgmname 10:21:36 4S@#00129  SDIQUMS ACCT  USER2  1
0000371 pgmname 10:21:36 SDIQUMS ACCT  USER2  SSTF8C311SDIQUMSR1000000000000000000
0000371 pgmname 10:21:36 SDIQUMSRACCT  USER2
          SSTF8C311001FFFFFFFFFFFFFFFFF0009D0A8E31EF460374DF4F2  "SYSTEM"ERRMSG"
0000371 pgmname 10:21:36 HI675000000079HI675 END OF DATA
    
```

Send file request trace sample

In the sample below, the Expedite/CICS send file command issued to the command processor and the response received from the command processor are shown.

```

Command or Message
0000223 pgmname 10:14:29 OVSAMFL2 VSBN  EXPSNDF ACCT  USER2  ACCT3  USER3  DVSAM2  N30
.
.
.
0000223 pgmname 10:14:31 HI00000
    
```

Trace interpretation:

Beginning with the first character under Command or Message, you can interpret the trace as described below.

This text:	Indicates the:
0	Command directly supported by the command processor
VSAMFL2	Name of the file being sent
VS	File type
B	Data type
N	File disposition
EXPSNDF	Send file command
ACCT	Sender's account ID
USER2	Sender's user ID
ACCT3	Destination account ID
USER3	Destination user ID
D	Destination type (Account/Userid or alias name)
VSAM2	Message user class
N	Verify before send option not specified
30	Number of days undelivered data will be retained
Y	Force selective receive

The send transaction is started to send data to Information Exchange. The Information Exchange send message commands follow. Four segments of data are sent. Each segment can contain the maximum transmission size; the default is 26000 characters.

```

Command or Message
0000224 pgmname 10:14:31 INITIATING SEND FUNCTION FOR ----> ACCT USER2 TO ACCT3 USER3
G0000056 VSA
0000224 pgmname 10:14:31 SDISNDM ACCT USER2 SSTF8C31 SACCT3 USER3 D SVSAM2 330F
0000224 pgmname 10:14:31 SDISNDM ACCT USER2 SSTF8C31S25875CACCT3 USER3 DA0000056 VSAM2
330F
0000224 pgmname 10:14:32 SDISNDM ACCT USER2 SSTF8C31E258751IN ALL.00014500 &TEST VSAM VSAM VSAM -
MMMMMMMMMMMMMMMMMMMMMMMMMMMMMMMM
0000224 pgmname 10:14:33 SDISNDM ACCT USER2 SSTF8C31 09050CACCT3 USER3 DA0000056 VSAM2
330F

```

Expedite/CICS converts the EXPSNDF command into the Information Exchange command, SDISNDM. After the end of the message group is sent, Expedite/CICS performs a commit with Information Exchange.

```

Command or Message
0000224 pgmname 10:14:33 SDICMIT ACCT USER2 SSTF8C31CMTRSPC 00004001

```

Information Exchange sends the data segments shown below to Expedite/CICS using SNA communication (EXPCICSS). Each segment can contain up to 26,000 characters, the maximum transmission size. When TCP/IP communication is used, EXPCICST is displayed instead of EXPCICSS.

```

Command or Message
0000272 pgmname 10:18:12 S0000006ACCT USER2 SSTF8C31 00060SACCT1 USER1 DSVSAM2
        6000581EXPCICSS4.5
0000272 pgmname 10:18:12 S0000006ACCT USER2 SSTF8C31S25875CACCT1 USER1 DA0000056 VSAM2
        6000582EXPCICSS4.5
0000272 pgmname 10:18:12 S0000006ACCT USER2 SSTF8C31E258752IN ALL00014500 &TEST VSAM VSAM VSAM
        -MMMMMMMMMMMMMMMMMMMMMMMMMMMM
0000272 pgmname 10:18:12 S0000006ACCT USER2 SSTF8C31 00050LACCT1 USER1 DA0000056 VSAM2
        6000583EXPCICSS4.5

```

Information Exchange issues a commit command (SDICMIT) to Expedite/CICS. Expedite/CICS indicates it has received the data and issues a commit response (SDICRSP) to Information Exchange.

```

Command or Message
0000272 pgmname 10:18:12 SDICMIT ACCT USER2 SSTF8C31SDICRSP 00004003
0000273 pgmname 10:18:13 SDICRSP ACCT USER2 SSTF8C310000100000041

```

In the sample below, a single receive request receiving multiple messages is shown receiving the second message in the mailbox that matches the request criteria. The first message has already been received. TCP/IP communication is being used.

```

Command or Message
0000276 pgmname 10:18:15 S0000006ACCT USER2 SSTF8C31 00060SACCT1 USER1 D SVSAM2
        6000584EXPCICSST4.5
0000276 pgmname 10:18:15 S0000006ACCT USER2 SSTF8C31S25875CACCT1 USER1 DA0000057 VSAM2
        6000585EXPCICST4.5
0000276 pgmname 10:18:15 S0000006ACCT USER2 SSTF8C31E258752IN ALL00014500 &TEST VSAM VSAM VSAM
        -MMMMMMMMMMMMMMMMMMMMMMMMMMMM
0000276 pgmname 10:18:15 S0000006ACCT USER2 SSTF8C31 09050LACCT1 USER1 DA0000057 VSAM2
        6000586EXPCICST4.5
0000276 pgmname 10:18:15 SDICMIT ACCT USER2 SSTF8C31SDICRSP 00004003
0000277 pgmname 10:18:16 SDICRSP ACCT USER2 SSTF8C310000200000041

```

The third message has been received. Information Exchange issues an ENDDATA to indicate there are no more messages. The last character on the first line (E) is the ENDDATA indicator. When data is delivered to the Expedite/CICS receive data (EXPRDAT) file, receive status is updated to COMPLETE. After data from EXPRDAT is delivered to the receive destination, status is updated to RECEIVED.

```

Command or Message
0000284 pgmname 10:18:19 S0000006ACCT USER2 SSTF8C31 00000E
0000284 pgmname 10:18:19 SDICMIT ACCT USER2 SSTF8C31SDICRSP 00000003
0000286 pgmname 10:18:19 SDICRSP ACCT USER2 SSTF8C310000400000001

```

Restart and recovery trace sample

In the following example, the activity monitor resets and restarts one user ID and reissues an associated receive request.

```

Command or Message
0000651 02/28/98 11:02:34 ACTIVITY MONITOR IS STARTING UP
0000651 pgmname 11:02:34 0 SDIINQS SYSTEM DEFAULT SDIINQSRL1
0000651 pgmname 11:02:34 SDIINQS SYSTEM DEFAULT DEFAULT SDIINQSRL1
0000651 pgmname 11:02:34 SDIERR THE FOLLOWING COMMAND WAS NOT EXECUTED BECAUSE: 00004SDIINQS
SYSTEM DEFAULT DEFAULT SDIIN
0000651 pgmname 11:02:34 HI00104SDIERR THE FOLLOWING COMMAND WAS NOT EXECUTED BECAUSE:
00004SDIINQS SYSTEM DEFAULT DEFAULT
0000651 pgmname 11:02:34 0 SDIINQS ACCT USER2 SDIINQSRL1
0000651 pgmname 11:02:34 SDIINQS ACCT USER2 SSTF8C31SDIINQSRL1
0000651 pgmname 11:02:34 SDIINQSRACCT USER2
SSTF8C31L94022811023494022809324401295000003400000016002427 000026000002600
0000651 pgmname 11:02:34 HI00104SDIINQSRACCT USER2
SSTF8C31L94022811023494022809324401295000003400000016002427 0000260
0000651 pgmname 11:02:34 0 SDIINQS ACCT USER001 SDIINQSRL1
0000651 pgmname 11:02:35 SDIINQS ACCT USER001 SSTF78WLSDIINQSRL1
0000651 pgmname 11:02:35 SDIERR THE FOLLOWING COMMAND WAS NOT EXECUTED BECAUSE: 00008SDIINQS
ACCT USER001 SSTF78WLSDIIN
0000651 pgmname 11:02:35 HI00104SDIERR THE FOLLOWING COMMAND WAS NOT EXECUTED BECAUSE:
00008SDIINQS ACCT USER001 SSTF78
0000651 02/28/98 11:02:35 EXPR ACCT USER001 STOPPAGE OF RECEIVE DETECTED, RESTARTING USER
0000651 pgmname 11:02:35 CLEANUP KICKED OFF FOR ----> ACCT USER001 RESET
0000651 pgmname 11:02:35 SDISSTA ACCT USER001 USER001 SDISSTAREXPICST4.50G2600000001SDICMIT
RESETS000000000000W
0000651 pgmname 11:02:36 SDISSTARACCT USER001 ST88AFLZ00000000000000003260000402
0000651 pgmname 11:02:37 4VSAMFL3 VSONYW00080SDIRCVM ACCT USER001 FILE1
0000651 pgmname 11:02:37 SDIRCVM ACCT USER001 ST88AFLZC0000048 FILE1
C0000048C0000048C0000048C00000
0000651 pgmname 11:02:37 HI00000C0000048
0000651 pgmname 11:32:37 0 SDIINQS ACCT USERZZZ SDIINQSRL1
0000651 pgmname 11:32:37 SDIINQS ACCT USERZZZ ST86A5M3SDIINQSRL1
0000651 pgmname 11:32:37 SDIINQSRACCT USERZZZ
ST86A5M3L94022811302379402281047180153310000000000000015331 00000000000000
0000651 pgmname 11:32:37 HI00104SDIINQSRACCT USERZZZ
ST86A5M3L9402281102369402281047180153310000000000000015331 0000000
0000652 pgmname 11:32:37 NO MORE DATA TO SEND FOR ----> ACCT USER001

```

Session end request trace sample

The sample below shows the session end request and the response from Information Exchange.

```

Command or Message
0001117 pgmname 19:10:07 0 SDISEND ACCT USER2
0001117 pgmname 19:10:07 SDISEND ACCT USER2 SSTD7TX1SDISENDR000001
0001117 pgmname 19:10:08 SDISENDRACCT USER2 SSTD7TX1000001
0001117 pgmname 19:10:08 HI00000

```

Expedite/CICS error messages

The next few examples show error messages being written when an error is encountered in Expedite/CICS. Error messages are always written to whichever trace destinations are in use. The messages below occurred during system startup when there was a problem connecting to Information Exchange. The activity monitor keeps trying to acquire the connection.

```

Command or Message
0000001 08/18/98 08:12:44 EXPR ACCT  USER2  EXPORST1 HI461 UNABLE TO ESTABLISH A SESSION WITH
INFORMATION EXCHANGE.
0000007 08/18/98 08:13:14 EXPR ACCT  USER2  EXPORST1 HI461 UNABLE TO ESTABLISH A SESSION WITH
INFORMATION EXCHANGE.
0000014 08/18/98 08:13:44 EXPR ACCT  USER2  EXPORST1 HI461 UNABLE TO ESTABLISH A SESSION WITH
INFORMATION EXCHANGE.
0000040 08/18/98 08:14:14 EXPR ACCT  USER2  EXPORST1 HI461 UNABLE TO ESTABLISH A SESSION WITH
INFORMATION EXCHANGE.
0000055 08/18/98 08:14:44 EXPR ACCT  USER2  EXPORST1 HI461 UNABLE TO ESTABLISH A SESSION WITH
INFORMATION EXCHANGE.
    
```

The problem shown below occurred because program EXPOSEL1 was disabled in CICS.

```

Command or Message
0000078 08/18/98 10:20:10 LGO1 ACCT  USER2  EXPOSEL1 HI916 PROGRAM DISABLED ON CICS TRANSFER
CONTROL
    
```

Severe error trace example

The messages above indicate a severe error which invoked the abend routine. The abend routine writes out CICS error information to assist in problem determination. The codes are used by systems support. The following information is provided for severe abends:

- The name of the transaction under which the error occurred
- The account ID and user ID for which the error occurred
- The name of the program in which the error occurred
- A message describing the error
- The last program paragraph name which executed and program text
- The abend code, if applicable
- The last data set name read; this may or may not pertain to the error code
- EIBFN; the last CICS command issued by the task
- EIBRCODE; the CICS response code returned by the last CICS command
- EIBRESP; a number corresponding to the response raised
- EIBRESP2; more detailed information about why the RESP condition occurred

```

Command or Message
0000099 08/18/98 10:26:42 LGO1 ACCT  USER2  EXPOISF1 HI922 TEMPORARY STORAGE QUEUE NOT FOUND.
0000042 08/18/98 10:26:42 LGO1 ACCT  USER2  EXPOISF1  1/3 PGM PARA: 0860A PGM TEXT: ERROR ON TS READ
0000042 08/18/98 10:26:42 LGO1 ACCT  USER2  EXPOISF1  2/3 ABEND:  LAST DSN: EXPDERR. EIBFN: 0A04
0000042 08/18/98 10:26:42 LGO1 ACCT  USER2  EXPOISF1  3/3 EIB-RCODE: 020000000000 RESP: 00000044
RESP2: 00000000
    
```

The messages below indicate that the receive was stopped. The activity monitor attempted to recover but could not. In this case, one option would be to reset the user session as described in “Reset a user session” on page 290, and then reissue the receive request.

```

Command or Message
0002229 08/19/98 17:50:33 ACCT01 USER09 STOPPAGE OF RECEIVE DETECTED, RESTARTING USER
0002478 08/19/98 18:50:34 ACCT01 USER09 STOPPAGE OF RECEIVE DETECTED, RESTARTING USER
0002704 08/19/98 19:50:35 ACCT01 USER09 STOPPAGE OF RECEIVE DETECTED, RESTARTING USER
0002927 08/19/98 20:50:36 ACCT01 USER09 STOPPAGE OF RECEIVE DETECTED, RESTARTING USER
0003154 08/19/98 21:50:37 ACCT01 USER09 STOPPAGE OF RECEIVE DETECTED, RESTARTING USER
0003381 08/19/98 22:50:38 ACCT01 USER09 STOPPAGE OF RECEIVE DETECTED, RESTARTING USER
0003609 08/19/98 23:50:39 ACCT01 USER09 STOPPAGE OF RECEIVE DETECTED, RESTARTING USER
0003832 08/20/98 00:50:41 ACCT01 USER09 STOPPAGE OF RECEIVE DETECTED, RESTARTING USER
0004059 08/20/98 01:50:41 ACCT01 USER09 STOPPAGE OF RECEIVE DETECTED, RESTARTING USER
0004287 08/20/98 02:50:42 ACCT01 USER09 STOPPAGE OF RECEIVE DETECTED, RESTARTING USER
0004514 08/20/98 03:50:43 ACCT01 USER09 STOPPAGE OF RECEIVE DETECTED, RESTARTING USER

```

In the sample below, the receive program was expecting variable length data (LL data type) and did not receive it.

```

Command or Message
0000740 08/21/98 11:55:43 IMR1 ACCT USER2 EXPOIRM3 HI460 INVALID LL DATA FILE RECEIVED.

```

Exception message layout

The following table describes the record layout of Expedite/CICS exception messages.

Field name	Field length
Task Number	7
Separator space	1
Date	8
Separator space	1
Time	8
Separator space	1
Program Name	8
Separator space	1
Return Code	8
Reason Code	8
Reason Message	74

In addition to the above fields, exception messages can also contain:

- The message which indicates that the receive has been stopped
- Abend information

In the sample below, the return code is 1 and the reason code is 61. According to the *IP CICS Sockets Guide*, 61 means that the connection was refused. In this case, the TCP/IP Relay was not up.

```
0000500 200002244 13:06:53 EXPOTISC 0000000100000061FAILURE ON EZASOKET CONNECT CALL
```

In the sample below, the return code is 1 and the reason code is 32. According to the *IP CICS Sockets Guide*, 32 means that the connection is broken. Support personnel can look in the TCP/IP log to determine what happened.

```
0000043 200002244 11:36:01 EXPOTISC 0000000100000032FAILURE ON EZASOKET SEND CALL
```

In the sample below, the return code is 1 and the reason code is 54. According to the *IP CICS Sockets Guide*, 61 means that the connection to the destination host was not available, that is, Information Exchange was not up.

```
0000043 200002244 11:36:01 EXPOTISC 0000000100000054FAILURE ON EZASOKET RECEIVE CALL
```

Log TDQ (EXPL)

The Expedite/CICS Log TDQ, EXPL, is used as a problem determination aid. Informational and error messages are always written to EXPL. Other information written to EXPL depends on the values in the Log Trace field and other options specified on the Trace Options panel.

If the value in the Log Trace field is Y, the first 125 bytes of whatever is written to the internal trace (as specified by the other trace flags) is also written to EXPL.

When you need to trace data over a long period of time, using EXPL avoids using a lot of temporary storage for the internal trace TSQs (EXPDTRCA and EXPDTRCB).

Defining EXPL

The EXPL destination is defined in the sample destination control table (DCT) provided with Expedite/CICS, and defaults to the SYS OUT queue as DSCNAME EXPLOG1. Although the name for EXPL is protected, you may use another DSCNAME in the DCT. This DSCNAME is used in the CICS startup JCL to identify the data set to which output is written.

Changing the DSCNAME would allow you to route the output to another data set, but be careful, because that data set may also fill up.

Whatever routing is used, you must provide:

- A DCT definition; all four characters must be entered and the first character cannot be a blank.
- A data definition (DD) statement in the CICS startup JCL:

The EXPL TDQ data format is the same as that shown in “Sample trace messages” on page 317.

Exception reporting TDQ (EXPM)

The EXPM TDQ is provided to alert systems support personnel to error conditions that interrupt continuous operations and, therefore, might require attention. If you rely on continuous Expedite/ CICS operations, the status of this queue should be monitored and alerts investigated. The following items are written to EXPM:

- Error messages of severity 08 and above.
- Activity monitor error messages. When the activity-monitor runs and a problem is detected with an outstanding receive request for a user, Expedite/CICS attempts to restart the user session and process the receive request. When this occurs, Expedite/CICS writes an informational message to EXPL and also to EXPM. The text of this message is:

STOPPAGE OF RECEIVE DETECTED. RESTARTING USER.

Defining EXPM

The EXPM destination is defined in the sample destination control table (DCT) provided with Expedite/CICS, and defaults to the SYSOUT queue as DSCNAME EXALERT. You can specify another name for EXPM on the System Options panel or another DSCNAME in the DCT. The DSCNAME is used in the CICS startup JCL to identify the data set to which output is written. If you use another name for EXPM, a corresponding change must be made in the DCT.

Changing the DSCNAME would allow you to route the output to another data set, but be careful, because that data set may also fill up.

EXPM can be defined as an intrapartition TDQ that triggers a CICS transaction when a record is written to route message entries to a specified destination, such as a monitored data set, a dedicated terminal, a printer, the console, or a sequential file.

Whatever routing is used, you must provide:

- A DCT definition; all four characters must be entered and the first character cannot be a blank
- A data definition (DD) statement in the CICS startup JCL (for an extrapartition TDQ only):

This TDQ can be routed to whichever destination best suits your installation. If you route to a terminal or printer, EXPM must be defined as an intrapartition TDQ.

The EXPM TDQ data format is the same as that shown in “Expedite/CICS error messages” on page 326. The EXPALERT copybook is also provided to show the layout of the EXPM TDQ.

TCP/IP error reporting TDQ (EXPT)

The EXPT TDQ is provided to alert systems support personnel to TCP/IP error conditions that interrupt continuous operations and, therefore, might require attention. If you rely on continuous Expedite/CICS operations, the status of this queue should be monitored and errors investigated. TCP/IP error messages of severity 08 and above relating to TCP/IP socket calls are written to this TDQ.

Defining EXPT

The EXPT destination is defined in the sample destination control table (DCT) provided with Expedite/CICSj, and defaults to the SYSOUT queue as DSCNAME EXPTCPIP. Although the name for EXPT is protected, you may use another DSCNAME in the DCT. This DSCNAME is used in the CICS startup JCL to identify the data set to which output is written.

Changing the DSCNAME would allow you to route the output to another data set, but use caution if you use this strategy because that data set might also fill up.

Whatever routing is used, you must provide:

- A DCT definition; all four characters must be entered and the first character may not be a blank.
- A data definition (DD) statement in the CICS startup JCL (for an extrapartition TDQ only).

Understanding automated restart and recovery

Expedite/CICS provides the activity monitor to perform automatic restart and recovery. The activity monitor is a CICS transaction that runs regardless of the process method used (Display Application, program interface, or batch interface). It runs periodically based upon the interval specified on the Display Application System Options panel.

The activity monitor performs a variety of functions that are performed based upon the mode of execution that Expedite/CICS requests. The three modes of execution are initialization, start (or restart) user, and monitor. These topics are presented as follows:

Initializing the system	350
Starting or restarting user sessions	350
Monitoring the system	350
Staying synchronized	351
Understanding restart and recovery options	352

Initializing the system

During CICS system startup, the Expedite/CICS startup program (EXPOSTRT) is started by the program list table (PLT) entry in CICS. If you are using TCP/IP communication, the TCP/IP listener task is also started. The startup program checks for necessary file control entries, such as the SYSTEM DEFAULT user profile record in the EXPDSRC file and two control records in the EXPDERR file, and adds entries as needed. It then starts the batch send transaction (EXPS) and the activity monitor transaction (EXPR) with an execution mode of INITIAL.

Under normal conditions, the activity monitor runs at an interval specified on the System Options panel. The default is 30 minutes.

For SNA communication, once the activity monitor has been activated, it checks the LU 6.2 connection and active user sessions with Information Exchange. If the connection cannot be acquired, Expedite/CICS repeats the startup process every 30 seconds until the connection and sessions with Information Exchange are established. This is important during connection failures, because Expedite/CICS attempts to recover automatically. Messages that indicate the connection or sessions with Information Exchange cannot be established are written to the log destinations to alert support personnel.

During initialization, the activity monitor automatically starts all user sessions that require activation such as those that previously had an active session, and those with the **Autologon** field set to **Y** in the user profile. For each user being started, the activity monitor starts another execution of the activity monitor, with the execution mode of START and the Account/Userid to be started.

Starting or restarting user sessions

The activity monitor starts or restarts users during CICS startup or reinitialization of the system after a connection or session failure. It also invokes start or restart when a recoverable failure occurs during an asynchronous send or receive processing. A recoverable failure includes a link or connection failure, or an out of synchronization condition (checkpoint counters mismatch) between Expedite/CICS and Information Exchange.

When a user session is restarted, Expedite/CICS determines if an Information Exchange session restart or reset is needed, depending on the status of the previous session. If a restart or reset is needed, Expedite/CICS files are backed out and a restart or reset is performed with Information Exchange.

- A restart will begin the user's session at the last commit successfully processed by Information Exchange.
- A reset will begin the user's session at the last successfully committed message group.

After the restart or reset, queued asynchronous send requests are started and outstanding single or continuous receive requests are reissued.

Monitoring the system

The activity monitor performs monitoring tasks at intervals specified on the System Options panel.

The activity monitor checks the connections with Information Exchange and user session status for all active users. If a problem is found, the activity monitor restarts with the execution mode of INITIALIZE. Otherwise, it checks user sessions to see if data is flowing for active receive requests. If no data flow is detected, the activity monitor queries the Information Exchange mailbox to determine if data should be flowing for both single and continuous receive requests. The message, STOPPAGE OF RECEIVE DETECTED, RESTARTING

USER, is written to the log destinations when a stoppage of a receive is detected. If the activity monitor determines that data should be flowing for a user session, it resets or restarts the user session, as described under “Starting or restarting user sessions” on page 332.

The only exception to the above is, because Expedite/CICS is unable to query mailboxes for distribution lists, whether or not data flow for distribution lists should be occurring cannot be determined.

The activity monitor also purges send and receive control records associated with successfully completed send and receive requests. The purge is done in accordance with the number of days specified in the Send File Retention and Receive Retention fields in the user’s profile. The activity monitor purges send request control and data records with a status of HIxxx or HELD as well as receive control and data records with a status of HIxxx, HELD, or COMPLETE after the number of days specified in the Not-Sent Not-Received Retention field in the Define System Options panel of the Display Application. It also updates the status of batch receives, and changes the status from COMPLETE to RECEIVED or HIxxx, after finding the result of the batch receive request in the EXPDPTF data set. To avoid peak processing times, these tasks are not done between the times specified on the Define System Options panel.



CAUTION: It is possible to start the activity monitor from a terminal, rather than from the Expedite/CICS Display Application. When this is done, however, it executes in monitor mode and does not restrict itself to off-shift hours but purges expired records and updates batch control records, regardless of what time it is.

Staying synchronized

Expedite/CICS uses group-level recovery when sending and receiving data to and from Information Exchange, which means that data is committed at the end of a message group. A message group is one or more Information Exchange messages that represent the object to be sent or received. This can be:

- A file, for non-EDI data
- An EDI interchange, for EDI data sent with file type E

Group-level recovery replaces message and checkpoint-level recovery used in Expedite/CICS Version 1. Group-level recovery improves performance when sending large messages by reducing the number of commit and commit response exchanges between Expedite/CICS and Information Exchange. A session restart will begin the user’s session at the last commit success-fully processed by Information Exchange.

Understanding restart and recovery options

The following restart and recovery system options can be modified:

- Activity monitor interval time (page 28)
- EXPM (EXALERT) destination (pages 28, 329)

The following restart and recovery user profile options should be tailored for each user ID on your system:

- Auto-Logon (page 23)
- Send file retention (page 23)
- Receive file retention (page 24)
- Send Processing, asynchronous or synchronous (page 26)

The following alert destinations are available to monitor the system:

- EXPL destination (page 329)
- EXPM destination (page 329)
- Internal trace (page 313)
- EXPT destination (page 330)

Sample Programs

This reference discusses the fact that Expedite/CICS provides sample programs to help you develop applications and maximize productivity. This reference does not list all available sample programs but describes where you can find them.

Sample programs are provided as is, without warranty of any kind, either express or implied, including (but not limited to) the implied warranties of merchantability and fitness for a particular purpose. The entire risk as to quality and performance of a sample program is with you. Should a program prove defective, then you must assume the entire cost of all necessary servicing or correction. GXS does not warrant that the functions contained in the programs will meet your requirements, or that the operation of such programs will be uninterrupted or free of errors.

The sample programs are available on the Expedite/CICS product tape. Installation instructions are provided in the *Expedite/CICS Program Directory*.

Sample programs on the install tape are:

EXPRC VAK	Receive Information Exchange acknowledgments
EXPRCVP1	Issue Receive Request
EXPRCVP2	Send Program
EXPSNDP1	Send Program
EXPOUEXT	Completion notification / user information monitor user exit.
EXPAUDRP	Audit Report Program

Finding Expedite/CICS sample programs

In addition to being distributed on the Expedite/CICS product tape, copies of the sample programs are also provided in the Expedite/CICS sample program library, EXCSAMPL, which is permanently stored on Information Exchange. Because the owning account and library name may be different on your Information Exchange system, you should use the List Library function to view a list of the programs. Use the Getmember command to retrieve a copy to your mailbox.

When changes are made to the sample program library, EXCSAMPL:

- The INDEX member will be updated.
- Revisions will be made available for distribution with the Expedite/CICS product tape, for future release or PTF distribution.

Table 84 on page 337 is not all-inclusive but shows the format of the INDEX member entries and how the how the Expedite/CICS sample audit report program is listed in the index.

Table 84. Expedite/CICS sample program library(EXCSAMPL) members

Member: Contents:			
INDEX	Description of the contents of the sample program library. Each entry in this member has the format shown below:		
	NOTE: JCL members are in MVS format.		
	<table border="0"> <tr> <td style="vertical-align: top;"> <p><u>PRIOR TO EXPEDITE/CICS REL 4.4</u></p> <p>Audit Report OVRAUDIT - sample overview SRCAUDIT - sample source code JCLAUDIT - sample JCL RPTAUDIT - sample report output</p> <p>Probe Command OVRPROBE - sample overview SRCPROBE - sample source code PNLPROBE - sample panel</p> <p>Information Exit OVRUEXIT - sample overview SRCUEXIT - sample source code</p> <p>Receive Acknowledgement OVRACK - sample overview SRCACK - sample source code</p> <p>Receive Command OVRPGM1 I - sample overview SRCPGM 1I - sample source code</p> <p>Receive Program OVRPGM2I - sample overview SRCPGM2I - sample source code</p> <p>Send Command OVRSPGMI - sample overview SRCSPGMI - sample source code</p> </td> <td style="vertical-align: top;"> <p><u>AFTER EXPEDITE/CICS REL 4.4</u></p> <p>Audit Report OVRAUDRP - sample overview EXPAUDRP - sample source code JCLAUDRP - sample JCL RPTAUDIT - sampl e report output (no change)</p> <p>Probe Command OVROPRB1 - sample overview EXPOPRB1 - sample source code EXPMPB1 - sample panel</p> <p>Information Exit OVROUEXT - sample overview EXPOUEXT - sample source code</p> <p>Receive Acknowledgement OVRCVACK - sample overview EXPRCVAK - sample source code</p> <p>Receive Command OVRRCVP1 - sample overview EXPRCVP1 - sample source code</p> <p>Receive Program OVRRCVP2 - sample overview EXPRCVP2 - sample source code</p> <p>Send Command OVRSNDP1 - sample overview EXPSNDP1 - sample source code</p> </td> </tr> </table>	<p><u>PRIOR TO EXPEDITE/CICS REL 4.4</u></p> <p>Audit Report OVRAUDIT - sample overview SRCAUDIT - sample source code JCLAUDIT - sample JCL RPTAUDIT - sample report output</p> <p>Probe Command OVRPROBE - sample overview SRCPROBE - sample source code PNLPROBE - sample panel</p> <p>Information Exit OVRUEXIT - sample overview SRCUEXIT - sample source code</p> <p>Receive Acknowledgement OVRACK - sample overview SRCACK - sample source code</p> <p>Receive Command OVRPGM1 I - sample overview SRCPGM 1I - sample source code</p> <p>Receive Program OVRPGM2I - sample overview SRCPGM2I - sample source code</p> <p>Send Command OVRSPGMI - sample overview SRCSPGMI - sample source code</p>	<p><u>AFTER EXPEDITE/CICS REL 4.4</u></p> <p>Audit Report OVRAUDRP - sample overview EXPAUDRP - sample source code JCLAUDRP - sample JCL RPTAUDIT - sampl e report output (no change)</p> <p>Probe Command OVROPRB1 - sample overview EXPOPRB1 - sample source code EXPMPB1 - sample panel</p> <p>Information Exit OVROUEXT - sample overview EXPOUEXT - sample source code</p> <p>Receive Acknowledgement OVRCVACK - sample overview EXPRCVAK - sample source code</p> <p>Receive Command OVRRCVP1 - sample overview EXPRCVP1 - sample source code</p> <p>Receive Program OVRRCVP2 - sample overview EXPRCVP2 - sample source code</p> <p>Send Command OVRSNDP1 - sample overview EXPSNDP1 - sample source code</p>
<p><u>PRIOR TO EXPEDITE/CICS REL 4.4</u></p> <p>Audit Report OVRAUDIT - sample overview SRCAUDIT - sample source code JCLAUDIT - sample JCL RPTAUDIT - sample report output</p> <p>Probe Command OVRPROBE - sample overview SRCPROBE - sample source code PNLPROBE - sample panel</p> <p>Information Exit OVRUEXIT - sample overview SRCUEXIT - sample source code</p> <p>Receive Acknowledgement OVRACK - sample overview SRCACK - sample source code</p> <p>Receive Command OVRPGM1 I - sample overview SRCPGM 1I - sample source code</p> <p>Receive Program OVRPGM2I - sample overview SRCPGM2I - sample source code</p> <p>Send Command OVRSPGMI - sample overview SRCSPGMI - sample source code</p>	<p><u>AFTER EXPEDITE/CICS REL 4.4</u></p> <p>Audit Report OVRAUDRP - sample overview EXPAUDRP - sample source code JCLAUDRP - sample JCL RPTAUDIT - sampl e report output (no change)</p> <p>Probe Command OVROPRB1 - sample overview EXPOPRB1 - sample source code EXPMPB1 - sample panel</p> <p>Information Exit OVROUEXT - sample overview EXPOUEXT - sample source code</p> <p>Receive Acknowledgement OVRCVACK - sample overview EXPRCVAK - sample source code</p> <p>Receive Command OVRRCVP1 - sample overview EXPRCVP1 - sample source code</p> <p>Receive Program OVRRCVP2 - sample overview EXPRCVP2 - sample source code</p> <p>Send Command OVRSNDP1 - sample overview EXPSNDP1 - sample source code</p>		

Using data compression

Compression reduces the size of files transmitted through Information Exchange. Significant savings in network charges and transmission time are possible when using data compression.

Expedite/CICS provides data compression through the Comm-Press** product. This product is required only if performing data compression or decompression. Both the sender and receiver of compressed data must have the Comm-Press product installed in order to compress and decompress the data.

The Comm-Press product may not be available in all countries. In the United States, contact your GXS Sales representative for Comm-Press product ordering information.

When using data compression, some Expedite/CICS send and receive parameters are affected, as described in the following sections.

Understanding the Comm-Press programs and files used with Expedite/CICS

The following programs are provided when you order the Comm-Press product. Please refer to the Program Directory for your version of the Comm-Press product for instructions on defining these resources to CICS.

COMPCICS This is the compression program. Expedite/CICS calls this program when data compression is requested in the Send File command. This program reads the file specified in the Send File command and places the compressed data in a temporary storage queue. Expedite/CICS then takes this compressed data, modifies the CDH to reflect that the data is compressed, indicates what type of data it is, and sends it to Information Exchange.

LKUPTBLC	This is the lookup table program. This program is only called if SFCOMPRESS=T is requested. This means that data will only be compressed if the sender and receiver of the data are found in the Lookup table and the compression parameter in that table entry is set to 'Y'. The format of the table is described later in this section.
DCMPCICS	This is the decompression program. When Expedite/CICS detects that the data being received is compressed (by looking at the CDH), it calls the DCMPCICS program to decompress the data. Expedite/CICS passes the name of a temporary storage queue holding this data. It also passes other values based on the CDH and the values specified in the receive command. DCMPCICS writes the decompressed data to the destination requested in the receive command.

Files that can be used as input to data compression

Any of the file management options supported by Expedite/CICS can be specified in the send command with Compression = Y or T.



NOTE: The Comm-Press product does not support a File Type of 'B' (insert logical length delimiters).

The COMPCICS program writes the data to a CICS temporary storage queue. The length of the records in the queue is determined by the transmission size specified in the Define System Options Panel of the Display Application. The size of the compressed data is limited by the size of this queue.

After compression, Expedite/CICS also updates the CDH for this file as follows:

- For both EDI and non-EDI data, the following fields are set:

COMPSOFT	Software used for compression (COMM-PRESS).
COMPSVER	Version of compression software used.
COMFNAME	Compressed file name. This is the name of the temporary storage queue where the compression program wrote the compressed data.
- For non-EDI data, it sets the data type (CTYPE) to 2 (binary) and the delimiter (DELIMIT) to 4 (None).
- No other fields are set for EDI data.

Files that can be used as output from the decompression program

There are no parameters in the receive command to specify data decompression. Expedite/CICS automatically decompresses the data based on the CDH of the data being received.

Expedite/CICS searches for the presence of 'COMM-PRESS' in the CDH. It then reads the compressed data records from the EXPRDAT file, builds a temporary storage queue, and passes this queue to the decompression program. Expedite/CICS also checks the CDH to see if this is EDI or non-EDI data and passes this information, along with the maximum record length specified, to the decompression program. DCMPCICS then writes the decompressed data to the destination requested in the receive command. Any of the current File Management types supported by Expedite/CICS Version 4 Release 3 can be specified when receiving data.

If writing to a temporary storage queue, a user receive program, or a transient data queue, the decompressed data must fit in one queue. Otherwise, DCMPCICS cannot decompress the data and a non-zero return code is returned to Expedite/CICS which in turn writes a message to the log. The compressed data is held in the receive (EXPRDAT) file.

If receiving compressed data, and compression/decompression support is not installed, the data is delivered uncompressed and a message is written to the log and to the trace (if trace options are set).



NOTE: If the fields are not properly set in the CDH, decompression will either not take place or the results will be unpredictable.

Other considerations when receiving compressed data

Because the decompression program reads the CDH to determine if it is receiving EDI or non-EDI data, it ignores the File Type parameter if specified in the receive command. For non-EDI data, DCMPCICS determines if CRLF was specified during compression or if the file should be treated with a type of O (no record delimiters).

If Handle Records As=S and receiving EDI compressed data, the data is handled as follows:

- If S and Max length is 0, data will be decompressed following these rules:
 - For EDIFACT and UN/TDI data, the data is written into 80-byte records.
 - For X12 and UCS, the data is written split by segments.
- If S and Max Length greater than 0, the results are unpredictable because this option is not supported by the Comm-Press product.
- If receiving non-EDI data and CRLF was specified on the send command, DCMPCICS will remove the CRLF delimiters. It will start each record on column one.

The Lookup Table—EXPDLKP

The compression lookup table indicates whether compression should be specified for a particular sender/receiver pair. It is only used with the SF-COMPRESS=T parameter, so you do not need to create it if you will not be using this feature.

The EXPDLKP file is a VSAM ESDS which must be defined to CICS using the instructions provided in the Program Directory.

When SF-COMPRESS=T is specified in the send command, Expedite/CICS calls program LKUPTBLC, passing the sender and receiver to this program. LKUPTBLC will search the EXPDLKP table for this sender receiver pair. If found, it checks if compression is to be performed between this pair. A return code is passed to Expedite/CICS to indicate the results of the search.

The records can be defined to the EXPDLKP file when the file is initialized, or you can add more records later using IDCAMS.

Each entry in the file must have the following format:

```
sender(sender) receiver(receiver) compress(y|n);
```

This value:	Means:
sender	Indicates the account and user ID or EDI source of a sender.
receiver	Indicates the account and user ID, alias or aliasname, listname or EDI destination of a receiver.
compress	Indicates whether compression should be performed for this sender/receiver pair. y Compress the data for this sender/receiver pair n Do not compress the data for this sender/receiver pair.

The following are examples of entries in a compression lookup table:

```
SENDER(acct1 user01) RECEIVER(acct1 user02) COMPRESS(y);
SENDER(acct1 user01) RECEIVER(alias1 alias2) COMPRESS(y);
SENDER(acct1 user01) RECEIVER(acct1 user03) COMPRESS(n);
SENDER(acct1 user01) RECEIVER(listname02) COMPRESS(y);
```

When sending non-EDI data, the sender's Expedite/CICS account and user ID are used as input to the search. For the receiver, it is what was specified in the send command: ACCT/USERID, list name, or alias name.

When sending EDI data, the sender and receiver are taken exactly as they are specified in the header, so the entries in the table must match exactly what appears in the appropriate field of the EDI header. The Expedite tables are not used to resolve any of the origin or destinations prior to calling the LKUPTBLC program.

The SF-COMPRESS=T parameter and the EXPDLKP file allow you to control what gets compressed, based on the receiver. The EXPDLKP file can be modified when your CICS region is not running.



NOTE: You can also modify it with CICS running if you do not add the name of the file to your CICS startup procedure and close the file using one of the CICS supplied transactions (CEMT). Of course, you need to ensure that Expedite/CICS is not trying to access this file.



Glossary

This glossary defines words as they are used in this book. It includes terms and definitions from the Dictionary of Computing (SC20-1699). If you are looking for a term and cannot find it here, reference this book for additional definitions.

A

account. A set of users who work for the same company.

account ID. A name that identifies an account to Information Exchange.

address. A user's account name and user identification (ID); used by Information Exchange to route messages.

alias. A nickname used in place of an account and user ID (Information Exchange address). Alias names are maintained in alias tables, which you can define as described in the *Information Exchange Administration Services User's Guide*.

alias table. A nickname file in Information Exchange that is defined by a table type, table ID, and alias name.

American National Standards Institute (ANSI). An organization for the purpose of establishing voluntary industry standards.

ANSI. American National Standards Institute.

archive. A place to store messages that users receive from Information Exchange for a specified period of time.

audit trail. A way of tracking and verifying basic information about the status of messages.

B

browse. To view a file on your terminal screen without changing it.

C

CICS. Customer Information Control System.

CICS/ESA. Customer Information Control System for Enterprise Systems Architecture that operates on a host system such as a System/370 or System/390.

CDH. common data header.

checkpoint-level. A restart and recovery method within Information Exchange that uses an exchange of Commit commands and responses (or Commit requests and responses) to break message transmissions into individual, recoverable pieces. Messages from Information Exchange are committed when Information Exchange receives your Commit response; messages that you send are committed when Information Exchange receives your next message, following Information Exchange's response to your Commit command.

command. (1) A word or abbreviation that you type at the terminal that tells the system to perform a task. (2) A character or group of characters (such as a word or abbreviation) that you enter, that tells the system to perform some task.

command line. The line on an interface panel where a user types commands.

command processor. A part of Expedite/CICS that processes commands passed to it either from a user program or from the Expedite/CICS Display Application.

commit. The point at which a message is either delivered, canceled, or purged. When a session fails, all uncommitted messages are lost.

common data header (CDH). Used by Information Exchange interfaces to provide additional descriptions of a message group.

compression. The process of eliminating gaps, empty fields, redundancies, and unnecessary data to shorten the length of records or blocks.

Customer Information Control System/Multiple Virtual Storage. A general-purpose licensed program that controls online communication between terminal users and a database.

D

data definition. (1) A program statement that describes the features of, specifies relationships of, or establishes context of data. (2) Information that describes the contents and characteristics of a field, record, or file. A data definition can include such things as field names, lengths, locations, and data types.

data set. The major unit of data storage and retrieval consisting of a collection of data in a prescribed arrangement and described by control information.

DCT. Destination control table.

DD. Data definition.

decompression. A function that expands data to the length that preceded data compression.

default. A value that a system automatically uses until you specify a different value.

destination. The final Information Exchange address to which a message is to be delivered.

destination control table (DCT). The CICS table defining the transient data destinations.

distribution list. A list of the addresses of users with whom a user communicates; it is used to send messages to or receive messages from several people without having to type their addresses.

E

EDIFACT. Electronic Data Interchange for Administration, Commerce, and Transportation.

electronic data interchange (EDI). The process of sending specially formatted business documents directly from one computer to another electronically.

Electronic Data Interchange for Administration, Commerce, and Transportation (EDIFACT). An electronic data interchange standard for administration, commerce, and transportation.

electronic mail. The process of sending freeformatted messages and formatted files from one computer to another.

Electronic Service Delivery. An electronic means of receiving service information and fixes, which otherwise would be obtained through slower distribution methods.

ESD. Electronic Service Delivery.

ESO. Extended Security Option.

Extended Security Option. An option that can be specified on the user profile, for users who require stricter security of data (extended security users).

Expedite/CICS. An interface available to CICS users who are connected to the network.

F

FCT. File control table.

file control table (FCT). A CICS table defining the processing of VSAM files.

G

global alias table. An alias that can be used by any Information Exchange user on a particular system.

group level recovery. A restart and recovery method within Information Exchange that commits data at the end of the message group.

H

header. The portion of a message that contains control information for the message, such as one or more destination fields, name of the originating station, input sequence number, and priority level for the message.

I

Information Exchange. (1) A communication service that permits users to send and receive information electronically. (2) A continuously running CICS application that stores and forwards information to trading partners.

Information Exchange Administration Services.

An online, panel-driven product an Information Exchange Service Administrator uses to perform administrative tasks for Information Exchange.

J

JCL. Job Control Language.

job card. The job control statement that identifies the beginning of a job. It contains such information as the name of the job, account number, and class and priority assigned to the job.

Job Control Language. A set of statements that identifies a job to the system and describes the requirements of the job.

L

logical unit (LU) 6.2. A type of logical unit that supports general communication between programs in a distributed processing environment. LU 6.2 is characterized by (a) a peer relationship between session partners, (b) efficient utilization of a session for multiple transaction, (c) comprehensive end-to-end

error processing, and (d) a generic application program interface (API) consisting of structured verbs that are mapped into a product implementation.

LU 6.2. Logical unit 6.2.

M

message. (1) An ordered series of characters intended to convey information that is transferred as an entity from an originator to one or more recipients. (2) In Information Exchange, a message may be either a complete message or a subset of a message group.

message acknowledgment. Response from Information Exchange that lets a user know whether or not sent data was delivered, received, or purged.

message group. One or more Information Exchange messages that represent the object to be sent or received.

message-level. A method of restart and recovery within Information Exchange in which a message is considered to be committed when its last segment is processed.

message segment. An Information Exchange message may be split into smaller components for transmission called Information Exchange message segments. An Information Exchange message segment consists of Information Exchange headers and data.

Multiple virtual storage. An IBM licensed program, which is a software operating system that controls the execution of programs.

MVS. Multiple virtual storage.

O

organizational alias. (1) An alias that can be used by any user in an account. (2) A company-wide alias table.

P

private alias. (1) An alias that can be used by any user in an account. (2) An individual user's alias table.

profile type. A category of users who all have the same level of authority for using Information Exchange functions.

password. A unique string of characters known to a computer system and to a user, who must specify the character string to gain access to a system and to the information stored within it.

processing program table (PPT). A table defining all application programs valid for processing under CICS. It also keeps track of whether or not an application program is in main storage.

PCT. Program control table.

PF key. Program function key.

PLT. Program list table.

Program control table. A CICS table defining all transactions that may be processed by the CICS system.

PPT. Processing program table.

program function (PF) key. A key on a terminal keyboard that gives the system a signal to perform a particular command.

program list table. A CICS table that contains a list of programs that are to be executed during CICS startup or during a controlled shutdown.

program temporary fix (PTF). A temporary solution or bypass of a problem resulting from a defect in a current unaltered version of the program.

PTF. Program temporary fix.

R

receive data. Files or message sent to you.

receive-side charges. The charges users incur when they receive messages through Information Exchange.

recovery level. The point from which a session needs to be restarted after a failure. Information Exchange has five levels of restart and recovery: checkpoint-, message-, session-, stream-, and group-level.

requests. Information Exchange sends Commit requests and Pace requests to assist in synchronization.

response. An Information Exchange reply to a response-oriented command.

S

send data. Files or messages you send.

send-side charges. The charges users incur when they send messages through Information Exchange.

ServiceLink. An electronic means of receiving service information and fixes, which otherwise would be obtained through slower distribution methods. Through ServiceLink, you can access service information online, instead of calling the support center.

service administrator. A person in your organization who has authority to perform various administrative tasks, such as setting system defaults and acting on behalf of other users when appropriate. In your operating environment, there may be Information Exchange service administrators and Expedite/CICS service administrators. Typically, a person might have authority to perform both functions, but not necessarily. Service administrators are often your primary contact for various network support groups; for example, Customer Care.

session. The period of time during which you can communicate with a computer system or one of its programs; usually, the elapsed time between logon and logoff.

T

TCP/IP. Transmission Control Protocol/Internet Protocol.

TDQ. Transient data queue.

Temporary storage queue. A storage location reserved for intermediate results.

trading partners. The business associates with whom users exchange information electronically.

Transient data queue. A storage location reserved for intermediate results. Expedite/CICS allows intrapartition or extrapartition TDQs, which must be defined in the CICS destination control table.

Transmission Control Protocol/Internet Protocol (TCP/IP). A set of communications protocols that support peer-to-peer connectivity functions for both local and wide area networks.

TSQ. Temporary storage queue.

U

UCS. Uniform Communication Standard.

Uniform Communication Standard (UCS). A standard EDI format used in the grocery industry.

UN/TDI. United Nations Trade Data Interchange.

United Nations Trade Data Interchange (UN/TDI). An electronic data interchange standard for administration, commerce, and transportation fields developed by the United Nations Economic Commission for Europe.

user class. A category used to group mail; agreed on among trading partners.

user ID. User identification.

user identification. (1) A string of characters that uniquely identifies a user to a system. (2) A name that identifies a user to Information Exchange within an account.

user profile. (1) In computer security, a description of a user that includes such information as user ID, name, password, access authority, and other attributes obtained at logon. (2) In Information Exchange, a user profile is a list of the characteristics of how a user works with Information Exchange. (3) In Expedite/CICS, a user profile describes how a user operates within Expedite/CICS and communicates with Information Exchange from Expedite/CICS.

V

Virtual Storage Access Method. An IBM access method for direct or sequential processing of fixed and variable length records on disk devices.

Virtual Telecommunications Access Method (VTAM). A set of programs that maintain control of the communications between terminals and application programs running under MVS and OS/390 operating systems.

VSAM. Virtual Storage Access Method.

VTAM. Virtual Telecommunications Access Method.

X

X12. An electronic data interchange standard that defines a specially formulated EDI data screen, approved by the American National Standards Institute (ANSI).



Index

A

- acquiring the LU 6.2 connection manually 311
- activity monitor
 - details 349
 - options 352
 - recovery checks 351
 - setting the interval 31
 - system initialization mode 350
 - transaction ID parameters 46
 - user session checks 350
 - additional application options 125
- address 3
- administrative response file
 - contents 73, 118
 - defining 302
 - immediate responses in 9, 67, 118
- Alias Inquiry command
 - command format 179
 - response format 180
- alias name
 - global 37
 - identifier 37
 - in EDI translate table 37
 - organization 37
- alias tables
 - global 37
 - organization 37
 - private 37
- application programs
 - calling when data is received 119
 - checking responses 67, 221, 282, 299
 - COMMAREA format 121
 - deleting data from Send/Receive/Control file 123

- deleting temporary storage queues containing data 123
- invoking 121, 122
- processing received data 121
- sample programs for batch interface 162
- selecting type of data received 118
- temporary storage queue containing data 121
- using data types in 118
- using to recover undeliverable messages 328
- writing data to a file 119
- Archive Query command 2
- Archive Retrieve command
 - COMMAREA format 182
 - temporary storage queue format 182
 - using 182
- asynchronous processing 98
- asynchronous send processing 28
- audit report 155
- Audit Retrieve command
 - COMMAREA format 185
 - response format 188
 - using 185
- auto create user 23
- auto logon 26

B

- batch interface
 - batch receive program 170
 - batch send keywords 165
 - batch send program 164
 - executing 164
 - inputs and outputs 164, 170
 - introduction 10 job
 - output 175
 - methods for processing data 159

- receive processing 171
- receiving data 160
- sample application programs 162
- sample job stream 164, 171
- sending data 160
- setting the interval 31
- transaction ID parameters 45
- using 164
- using CICS master terminal commands 160
- using internal reader facility 162
- using VSAM data sets 160
- Browse Library Member command
 - command format 190
 - response format 191, 304

C

- Cancel command
 - COMMAREA format 192
 - response format 196
 - temporary storage queue format 192
 - using 192
- CEDF (CICS Executive Diagnostic Facility) 306
- CEMT command 160, 311, 312
- changing system-wide options 30
- charges 16, 211, 232, 270, 280
- checking your LU 6.2 sessions 312
- CICS
 - communicating with Information Exchange 4
 - CICS Executive Diagnostic Facility (CEDF) 306
 - CICS master terminal commands in batch
 - interface 160
- command processor
 - commands supported 7
 - definition 362
 - module 70
 - overview 7
 - receiving responses from 72
 - sending commands to 69, 110
 - sending pass-through commands to 70
 - sending pass-through commands to 70
- commands
 - Archive Retrieve 182
 - Audit Retrieve 185
 - Cancel 192
 - CEMT 160, 311, 312
 - directly supported 69
 - LINK 8, 71, 121
 - List Define 217
 - list of 177
 - list of Information exchange 2

- List verify 230
- Load Test Message 233
- Message Inquiry 235
- Probe 245
- Purge Message 251
- Receive Message 8
- Receive message 8 response oriented 294
- response-oriented 9, 182, 235, 285, 288
- RETURN 122
- Send File 274
- send file 9
- Session End 285
- Session Inquiry 288
- Session Start 294
- Set Administrative Response File 302
- supported by command processor 69
- supporting data types 11
- COMMAREA 274
 - Alias Inquiry format 179
 - Archive Retrieve format 182
 - Audit Retrieve format 185
 - Cancel format 192
 - default values 69
 - Define Alias format 197
 - description 8
 - fields required 68
 - HI000 or HI001 response format 71
 - HI001 response format using pass-through 72
 - information in 68
 - List Define format 218
 - List Verify format 230
 - Load Test Messages format 233
 - Message Inquiry format 235
 - passed to application format 121
 - pass-through command format 70
 - Probe format 245
 - Receive Message format 253
 - SDIERR message 74
 - security exit format 142
 - Send File format 274
 - Session End format 285
 - Session Exit format 139
 - Session Start format 294
- COMMAREA HIxxx response format 73
- COMMAREA
 - Session Inquiry format 288
- common data header (CDH)
 - format 144
 - purpose 112, 143
- common data header(CDH) 255

- command format 272
- communication area 8
- Completion notification exit 134
- compression 324
- compression, problems 324
- Continuous Receive
 - defining a storage area for 111
 - description 110
 - identifying incoming data 118
 - introduction 8
 - using 110, 253
- CRLF 92
- CRLF (Carriage return linefeed) data type 255
- CRLF data type 113
- CRLF(Carriage return linefeed) data type 274

D

- data compression 112
- data types
 - CRLF 92, 113, 255, 274
 - EDI 92, 113, 255, 274
 - EDIFACT 92, 96, 114, 255, 274
 - LL 92, 93, 113, 255, 274
 - OTHER 92, 93, 114, 255, 274
 - UCS 92, 96, 114, 255, 274 UN/TDI 92, 97, 114, 255, 274
 - using to manage files and messages 113, 118, 255, 274
 - X12 92, 95, 114, 255, 274
- default temporary storage queue (EXPDRE1) 118
- default values
 - in COMMAREA format 68 in pass-through commands 70
 - overriding 69
 - permanently changing 69
 - temporarily overriding 69
 - using 68
- Define Alias command
 - COMMAREA format 197
 - response format 200
 - temporary storage queue format 199
- Define Alias format 197
- Define Library command
 - COMMAREA format 201
 - response format 204
- defining
 - administrative response file 302
 - CICS environment 306
 - storage area for single or continuous receive 111

- Delete Library Member command command format 207
 - response format 208
- determination
 - internal trace queues 331
 - trace facility 331
- diagnosing and solving problems
 - acquiring the LU 6.2 connection manually 311
 - CEDF 306
 - checking your LU 6.2 sessions 312
 - establishing a session with Information Exchange 306
 - investigating problems 305
 - recovering undeliverable messages 328
- display application
 - using to receive batch data 170
- distribution list format 217

E

- EDI (Electronic data interchange) data type 113, 255, 274
- EDI(Electronic data interchange) data type 92
- EDIFACT data type 92, 96, 114, 255, 274
- error log destination
 - LOG TDQ (EXPL) 346
- error messages 344
 - creation of 72
 - Expedite/CICS 72
 - format for 72
 - groups of 122
 - HI000 or HI001 COMMAREA format 71 HI001 response format using pass-through 72 HIxxx COMMAREA format 73
 - Information Exchange 72, 73
 - numbers 122
 - receiving 72, 73, 109
 - return code 71, 122
 - SDIERR 72, 74
 - SDIERR format 74
 - severity code 71, 122
 - types of 72
 - where stored 73, 118
- error processing
 - receive 117
 - send 102
- errors 72
- establishing a session with Information Exchange 306
- exception log (EXPL) 346
- exception reporting TDQ (EXPM) 347

exits

- completion notification 134
- information collection 134
- information monitor 134,135
- Security Exit 141
- session 139
- standard user exit program layout 135
- types of 138
- user exit program processing 138
- EXPDPRM 88

- EXPDRE1 302
- EXPDSRC 118
- EXPDSRC (Send/Receive/Control file) 118
- EXPDTRCA/B 331

Expedite 311
Expedite/CICS

- envelopes 115
- locating EDI destinations 93
- message name 106
- message sequence number 107
- message user class 104
- receiving 114
- sending 93, 94
- Specifying Information Exchange control fields 105

- Expedite/CICS message format 123
- Expedite/CICS messages 72

- EXPL 346
- EXPM 347
- EXPMRES, Information Exchange - Reset Session 309
- EXPMTR1, Trace Options 335
- EXPOICMD 70, 110
- EXPOSCX1 141
- EXPOSES1 139

G

- getting system information items in a mailbox 230

H

- HI000 or HI001 response format 71
- HI001 response format using pass-through 72
- HIxxx response format 73

I

- Information Exchange acknowledgment format 127

audit trails

- introduction 150
- level 1 format 151
- level 2 format 156
- error system messages 73
- mailbox 157
- mailbox items 109
- receiving data from 109
- sending data to 92, 274
- starting a session 294
- identifying incoming messages and data 118
- IDLT, resetting a user session 309
- immediate responses 71, 118
- information about your mail 235
- information collection exits 134
- Information Exchange
 - audit trails, retrieving 150
 - information monitor exit 135
 - informational messages 332
- Initializing 350
- inquiring about Information Exchange items in a mailbox 235 session 288
- internal reader facility in batch interface 162
- internal trace examples 335
- internal trace queues (EXPDTRCA/B) 331
- ISC2 (receive data task) 118

J

- job output 175

K

- Keywords for batch send program 165

L

- libraries
 - description,libraries managing 126 working with 126
- Library 268
- Library entry item structure 224
- Library Member command list entry format 228
- Library Search command command format 214
- LINK command 70, 110, 121, 139, 141

- List Define command
 - command format 205
 - COMMAREA format 218
 - distribution list format 217
 - possible errors 221
 - response format 206, 221
 - using 217
 - List Library command
 - command format 222
 - List Library Member command
 - command format 227
 - List Verify command
 - COMMAREA format 230
 - response format 232
 - using 230
 - LL (Logical Length records) data type 93, 255, 274
 - LL(Logical Length records) data type 92
 - Load Test Messages command
 - COMMAREA format 233
 - temporary storage queue 233
 - using 233
 - log destinations 346
 - Log TDQ (EXPL) 346
 - Logical-length data type 113
 - long format Session Inquiry response 289
- M**
- mailbox responses 109
 - mailbox, Information Exchange
 - mailbox responses in 109
 - managing libraries 126
 - Message Inquiry command
 - COMMAREA format 235
 - response format 236
 - temporary storage queue 236
 - using 235
 - message name 106
 - Message queue entry 240
 - Message Queue Query command
 - command format 239
 - message sequence number 107
 - messages
 - error 72
 - Expedite/CICS 72
 - format for 73
 - groups of 122
 - HI000 or HI001 response format 71
 - HI001 response format using pass-through 72
 - HIxxx response format 73
 - Information Exchange 73
 - numbers 122
 - purging 251
 - receiving 73, 109
 - recovering 328
 - return code 71, 122
 - SDIERR 74
 - SDIERR format 74
 - severity code 71, 122
 - where stored 73, 118
 - methods for processing batch data 159
 - MSGNAME, assigning 106 MSGUCLS
 - assigning for EDIFACT and UN/TDI data 105
 - assigning for X12 and UCS data 105
- O**
- OTHER (free format) data type 93, 114, 255, 274
 - OTHER(free format) data type 92
 - overriding default values 69
- P**
- panels, list of
 - Trace Options 335
 - pass through commands
 - HI001 COMMAREA response format 72
 - passing data to command processor 69
 - pass-through commands
 - default values 70
 - pass-through commands
 - Archive Retrieve 182
 - Cancel 192
 - COMMAREA format 70
 - Define Alias 197
 - List Verify 230
 - Load Test Message 233
 - Message Inquiry 235
 - sending to command processor 70
 - Session Inquiry 288
 - permanently changing default values 69
 - Probe command
 - asynchronous response format 248
 - COMMAREA format 245
 - synchronous response format 249
 - using 245
 - problem
 - acquiring the LU 6.2 connection manually 311
 - checking data sets and programs 326
 - checking program definitions 306
 - checking status of destination data sets 326

- checking status of VSAM data sets 326
- communicating with Information Exchange 308
- determination
 - elements written to 332
 - sample trace messages 335
- diagnosing and solving 305
- error log TDQ 347
- establishing a session with Information Exchange 306
- exception reporting TDQ 347
- LU 6.2 troubleshooting table 313
- problem determination tables 321
- receive data troubleshooting table 316
- recovering undeliverable messages 328
- restarting a session 308
- send data troubleshooting table 321
- session start troubleshooting table 315
- with your application 306, 307
- problems
 - error messages 344
- processing
 - application data 121
 - batch data 159
 - Continuous Receive command 118
 - receive data types 113
 - send data types 92
 - Single Receive command 118
- Purge Message command 251

R

- receive
 - batch 171
 - error processing 117
- receive data task (ISC2) 118
- Receive Message command
 - common data header 112, 143, 255
 - Continuous Receive 110
 - messages and responses 109
 - Single Receive 110
 - types of 110, 258
 - using 73, 109
- Receive message command
 - mailbox responses 109
- receiving data
 - from command processor 72
 - in the batch environment 160
 - methods of 109
 - Receive Message command 109
 - sample messages to test system 233
- recovering undeliverable messages 328

- recovery
 - messages 328
- response formats to commands
 - application 121
 - Archive Retrieve 182
 - asynchronous Probe 248
 - Audit Retrieve 188
 - Define List 221
 - HI000 or HI001 response format 71
 - HI001 response format using pass-through 72
 - HIxxx response format 73
 - Library PutMember 212
 - Message Inquiry 236
 - Probe 248
 - Session End 287
 - Session Start 298
 - synchronous Probe 249
- response-oriented commands
 - Archive Retrieve 183
 - Audit Retrieve 188
 - Message Inquiry 235
 - Probe 245
 - Session Inquiry 288
 - Session Start 294
- Responses
 - deferred 109
 - from the command processor 72
 - immediate 71
 - receiving 109
 - return code 71
 - security exit 142
 - severity code 71
- Retrieve Library Member command 268
 - command format 268
- return code 71, 122
- RETURN command 122

S

- sample batch procedure to recover undeliverable messages 329
- sample job streams
 - for executing batch receive program 171
 - for executing batch send program 164
- sample messages to test system 233
- sample online application program to recover undeliverable messages 328
- sample programs for batch interface 162
- SDIERR messages
 - common reasons 74
 - format 74

- from Browse Library Member command 191
 - from Define Alias command 200
 - from Define Library command 204
 - from Library Search command 216
 - from List Define command 221
 - from Receive Message command 260
 - from Retrieve Library command 271
 - from Retrieve Library Member CDH command 273
 - from Session Start command 299
 - from Set Administrative Response File command 304
 - from xxxxxxxxxxxx command 196,200,206, 208, 212, 223, 228, 232, 240
 - understanding 74
 - security exit
 - description 139
 - responses to 142
 - working with 141
 - SEDIERR messages
 - from xxxxxxxxxxxx command 191
 - Send File command
 - COMMAREA format 274
 - common data header 112, 143
 - response format 212
 - using 274
 - Send Message command
 - common data header 112, 143
 - Send/Receive/Control file (EXPDSRC)
 - contents 77
 - deleting data 102
 - sending
 - EDI data 93
 - processing overview 98
 - synchronous or asynchronous 98
 - sending data
 - how data types are processed 92
 - in the batch environment 160 to
 - the command processor 69
 - using data types 92
 - using pass-through 70
 - session
 - access key 70
 - ending 285
 - starting 294, 306
 - Session End command
 - COMMAREA format 285
 - possible errors 287
 - response format 287
 - using 285
 - session exit
 - description 139
 - responses to 139
 - working with 139
 - Session Inquiry command
 - Information Exchange session 288
 - items in mailbox 235
 - responses to 289
 - session restart 308
 - using 288
 - session reset, IDLT 309
 - Session Start command
 - format of 294
 - required fields 295
 - response to 298
 - using 294, 306
 - Set Administrative Response File command
 - description 69
 - response format 304
 - using 302
 - severity code 71, 122
 - short format Session Inquiry response 290
 - sing commands
 - pass-thorough 288
 - Single Receive
 - defining a storage area for 111
 - description 110
 - identifying incoming data 118
 - using 110
 - single receive control file
 - contents 118
 - deleting data 123
 - storage area for single or continuous receive 111
 - synchronous processing 100
 - system messages 73
- ## T
- TCP/IP
 - errors 319
 - Relay problems 315
 - socket problems 315, 319, 322
 - TCP/IP override parameters 88
 - temporary storage queue format
 - Archive Retrieve command 182
 - Cancel comamnd 192
 - Define Alias command 199
 - Load Test Message command 233
 - Message Inquiry command 236 sending to the command processor 70
 - temporary storage queues
 - application 121

- common data header 144
- deleting application 122
- EXPDRE1 118, 302
- terminal control table 306
- trace facility 331
- Trace Options panel 335

U

- UCS (Uniform Communication Standard) data
 - type 255, 274
- UCS data type 96, 114
- UCS (Uniform Communication Standard) data
 - type 92
- UN/TDI data type 92, 97, 114, 255, 274
- UNIQUEID assignment 106, 128
- user class
 - definition 104
 - send file 104
 - using to specify mail 104
- user information exit 100, 102, 174
- user information monitor exit 117
- using
 - batch interface 164
 - CICS master terminal commands with batch
 - interface 160
 - commands in your application 177
 - data types 92, 113, 118, 255, 274
 - default values 69
 - internal reader facility 162
 - keywords 165
 - pass-through 70
 - VSAM data sets with batch interface 160
- using commands
 - Archive Retrieve 182
 - Audit Retrieve 185
 - Cancel commands 192
 - Continuous Receive 110
 - List Define 217
 - List Verify 230
 - Load Test Message 233
 - Message Inquiry 235
 - pass-through 182, 192, 197, 199, 230, 233, 235
 - Probe 245
 - Purge Message 251
 - Receive Message 73, 109
 - response-oriented 285, 288, 294
 - Send File 274
 - Session End 285
 - Session Inquiry 288
 - Session Start 294

- Set Administrative Response File 302
- Single Receive 110
- Start Session 306

V

- VSAM data sets in batch interface 160

W

- working with exits 134
- wrapping data
 - when storing receive data 256

X

- X12 (ANSI X12 standard) data type 92, 95, 255, 274

